



Cisco StrataCom BPX Service Node Reference

Release 8.5
May 15, 1998

Corporate Headquarters

Cisco Systems, Inc.
170 West Tasman Drive
San Jose, CA 95134-1706
USA

World Wide Web URL:

<http://www.cisco.com>

Tel: 408 526-4000

800 553-NETS (6387)

Fax: 408 526-4100

Customer Order Number: DOC-SCBPXRG-8.5=
Text Part Number: 78-4689-01

THE SPECIFICATIONS AND INFORMATION REGARDING THE PRODUCTS IN THIS MANUAL ARE SUBJECT TO CHANGE WITHOUT NOTICE. ALL STATEMENTS, INFORMATION, AND RECOMMENDATIONS IN THIS MANUAL ARE BELIEVED TO BE ACCURATE BUT ARE PRESENTED WITHOUT WARRANTY OF ANY KIND, EXPRESS OR IMPLIED. USERS MUST TAKE FULL RESPONSIBILITY FOR THEIR APPLICATION OF ANY PRODUCTS.

THE SOFTWARE LICENSE AND LIMITED WARRANTY FOR THE ACCOMPANYING PRODUCT ARE SET FORTH IN THE INFORMATION PACKET THAT SHIPPED WITH THE PRODUCT AND ARE INCORPORATED HEREIN BY THIS REFERENCE. IF YOU ARE UNABLE TO LOCATE THE SOFTWARE LICENSE OR LIMITED WARRANTY, CONTACT YOUR CISCO REPRESENTATIVE FOR A COPY.

The following information is for FCC compliance of Class A devices: This equipment has been tested and found to comply with the limits for a Class A digital device, pursuant to part 15 of the FCC rules. These limits are designed to provide reasonable protection against harmful interference when the equipment is operated in a commercial environment. This equipment generates, uses, and can radiate radio-frequency energy and, if not installed and used in accordance with the instruction manual, may cause harmful interference to radio communications. Operation of this equipment in a residential area is likely to cause harmful interference, in which case users will be required to correct the interference at their own expense.

The following information is for FCC compliance of Class B devices: The equipment described in this manual generates and may radiate radio-frequency energy. If it is not installed in accordance with Cisco's installation instructions, it may cause interference with radio and television reception. This equipment has been tested and found to comply with the limits for a Class B digital device in accordance with the specifications in part 15 of the FCC rules. These specifications are designed to provide reasonable protection against such interference in a residential installation. However, there is no guarantee that interference will not occur in a particular installation.

You can determine whether your equipment is causing interference by turning it off. If the interference stops, it was probably caused by the Cisco equipment or one of its peripheral devices. If the equipment causes interference to radio or television reception, try to correct the interference by using one or more of the following measures:

- Turn the television or radio antenna until the interference stops.
- Move the equipment to one side or the other of the television or radio.
- Move the equipment farther away from the television or radio.
- Plug the equipment into an outlet that is on a different circuit from the television or radio. (That is, make certain the equipment and the television or radio are on circuits controlled by different circuit breakers or fuses.)

Modifications to this product not authorized by Cisco Systems, Inc. could void the FCC approval and negate your authority to operate the product.

The following third-party software may be included with your product and will be subject to the software license agreement:

CiscoWorks software and documentation are based in part on HP OpenView under license from the Hewlett-Packard Company. HP OpenView is a trademark of the Hewlett-Packard Company. Copyright © 1992, 1993 Hewlett-Packard Company.

The Cisco implementation of TCP header compression is an adaptation of a program developed by the University of California, Berkeley (UCB) as part of UCB's public domain version of the UNIX operating system. All rights reserved. Copyright © 1981, Regents of the University of California.

Network Time Protocol (NTP). Copyright © 1992, David L. Mills. The University of Delaware makes no representations about the suitability of this software for any purpose.

Point-to-Point Protocol. Copyright © 1989, Carnegie-Mellon University. All rights reserved. The name of the University may not be used to endorse or promote products derived from this software without specific prior written permission.

The Cisco implementation of TN3270 is an adaptation of the TN3270, curses, and termcap programs developed by the University of California, Berkeley (UCB) as part of UCB's public domain version of the UNIX operating system. All rights reserved. Copyright © 1981-1988, Regents of the University of California.

Cisco incorporates Fastmac and TrueView software and the RingRunner chip in some Token Ring products. Fastmac software is licensed to Cisco by Madge Networks Limited, and the RingRunner chip is licensed to Cisco by Madge NV. Fastmac, RingRunner, and TrueView are trademarks and in some jurisdictions registered trademarks of Madge Networks Limited. Copyright © 1995, Madge Networks Limited. All rights reserved.

XRemote is a trademark of Network Computing Devices, Inc. Copyright © 1989, Network Computing Devices, Inc., Mountain View, California. NCD makes no representations about the suitability of this software for any purpose.

The X Window System is a trademark of the X Consortium, Cambridge, Massachusetts. All rights reserved.

NOTWITHSTANDING ANY OTHER WARRANTY HEREIN, ALL DOCUMENT FILES AND SOFTWARE OF THESE SUPPLIERS ARE PROVIDED "AS IS" WITH ALL FAULTS. CISCO AND THE ABOVE-NAMED SUPPLIERS DISCLAIM ALL WARRANTIES, EXPRESSED OR IMPLIED, INCLUDING, WITHOUT LIMITATION, THOSE OF MERCHANTABILITY, FITNESS FOR A PARTICULAR PURPOSE AND NONINFRINGEMENT OR ARISING FROM A COURSE OF DEALING, USAGE, OR TRADE PRACTICE.

IN NO EVENT SHALL CISCO OR ITS SUPPLIERS BE LIABLE FOR ANY INDIRECT, SPECIAL, CONSEQUENTIAL, OR INCIDENTAL DAMAGES, INCLUDING, WITHOUT LIMITATION, LOST PROFITS OR LOSS OR DAMAGE TO DATA ARISING OUT OF THE USE OR INABILITY TO USE THIS MANUAL, EVEN IF CISCO OR ITS SUPPLIERS HAVE BEEN ADVISED OF THE POSSIBILITY OF SUCH DAMAGES.

AccessPath, AtmDirector, Cache Director System, CD-PAC, Cisco IOS, the Cisco IOS logo, *CiscoLink*, the Cisco Powered Network logo, ClickStart, ControlStream, Fast Step, FragmentFree, IGX, JumpStart, LAN²LAN Enterprise, LAN²LAN Remote Office, MICA, NetBeyond, NetFlow, Netsys Technologies, *Packet*, PIX, Point and Click Internetworking, RouteStream, SMARTnet, StrataSphere, StrataSphere BILLder, StrataSphere Connection Manager, StrataSphere Modeler, StrataSphere Optimizer, Stratm, StreamView, SwitchProbe, *The Cell*, TokenSwitch, TrafficDirector, VirtualStream, VlanDirector, Workgroup Director, Workgroup Stack, and XCI are trademarks; The Network Works. No Excuses. is a service mark; and BPX, Catalyst, Cisco, Cisco Systems, the Cisco Systems logo, EtherChannel, FastHub, FastPacket, ForeSight, IPX, LightStream, OptiClass, Phase/IP, StrataCom, and StrataView Plus are registered trademarks of Cisco Systems, Inc. in the U.S. and certain other countries. All other trademarks mentioned in this document are the property of their respective owners.

Cisco StrataCom BPX Service Node Reference

Copyright © 1997, Cisco Systems, Inc.

All rights reserved. Printed in USA.

978R

About this Publication xvii

Objectives xvii
 Audience xvii
 Organization xviii
 Related Documentation xx
 Conventions xx

Chapter 1 Introduction 23

General Description 23
 BPX Capabilities 23
 Extended Services Processor 24
 Access Devices 24
 New with Release 8.5 25
 Network 25
 AXIS 25
 StrataSphere Network Management 25
 IGX 25
 New with Release 8.4 25
 Continuing Features with Release 8.5 and 8.4 27
 StrataSphere Network Management 27
 Network 27
 BPX Service Node 27
 AXIS 28
 BPX Operation 28
 The BPX Service Node with AXIS Shelves 28
 The BPX Service Node with ESP 28
 BPX Switching 28
 Frame Relay to ATM Interworking 29
 Network Interworking 29
 Service Interworking 30
 Additional Information 31
 Tiered Networks 31
 Routing Hubs and Interface Shelves 31
 BPX Routing Hubs 31
 IMA (Inverse Multiplexing ATM) 33
 Virtual Trunking 33
 Traffic and Congestion Management 34
 FairShare
 OptiClass
 AutoRoute 36
 PNNI 36
 Congestion Management, VS/VD 36
 Congestion Management, ForeSight 36
 Network Management 37
 Network Interfaces 38

	Service Interfaces	38
	Statistical Alarms and Network Statistics	38
	Node Synchronization	39
	Node Availability	39
	Node Redundancy	40
	Node Alarms	40
Chapter 2	BXM T3/E3, 155, and 622	3-1
	BXM Cards	3-1
	BXM Capabilities	3-4
	Features	3-4
	ATM Layer	3-5
	Service Types	3-5
	Card Operation	3-7
	BXM Front Card Indicators	3-7
	BXM, Backcard Connectors	3-11
	Y-Cabling of SMF-622 Series Backcards	3-15
	BXM Functional Description	3-16
	Overview, Port (UNI) Mode	3-16
	Ingress	3-16
	Egress	3-18
	Overview, Trunk Mode	3-19
	Ingress	3-19
	Egress	3-20
	Detailed Description, Port (UNI) and Trunk Modes	3-21
	DRSIU	3-21
	SONET/SDH UNI (SUNI)	3-21
	DeMux/Mux	3-21
	RCMP	3-21
	SABRE	3-21
	Ingress and Egress Queue Engines	3-22
	SIMBA	3-22
	ACP Subsystem Processor	3-22
	Fault Management and Statistics	3-23
	Fault Management and Statistics, Port (UNI) Mode	3-23
	Fault Management and Statistics, Trunk Mode	3-24
	Technical Specifications	3-25
	Physical Layer	3-25
	General Information	3-25
	General SONET Notes	3-26
	User Commands	3-27
	Connection Provisioning	3-27
	Diagnostics	3-27
	Test	3-27
	Statistics	3-27
	Configuring Connections	3-28

	Configuration Management	3-29
	Command Line Interface Examples	3-30
	Configuring the BPX for SVCs	3-39
	Configuring the AXIS	3-39
	Resource Partitioning	3-40
	ASI SVC Resource Partitioning	3-41
	BXM SVC Resource Partitioning	3-43
	NNI Trunk SVC Resource Partitioning	3-45
	BNI Trunk SVC Resource Partitioning	3-46
	BXM Trunk SVC Resource Partitioning	3-47
Chapter 3	ATM Connections	4-1
	ATM Connection Services	4-1
	SVCs	4-2
	Traffic Management Overview	4-3
	ABR, Standard ATM Traffic Mgt 4.0	4-4
	Standard ABR notes:	4-4
	VSVD Description	4-4
	BXM Connections	4-4
	ForeSight Congestion Control	4-5
	ATM Connection Requirements	4-5
	Connection Routing	4-6
	Addcon Command Syntax	4-6
	ATM Connection Configuration	4-8
	CBR Connections	4-14
	VBR and ATFR Connections	4-15
	VBR Connections	4-15
	4-16	
	ATFR Connections	4-16
	ABR Notes	4-18
	ABR and ATFST Connections	4-18
	ABR Connections	4-18
	ATFST Connections	4-21
	UBR Connections	4-23
	LMI and ILMI Parameters	4-24
Chapter 4	Configuration and Management	5-1
	Initial Setup	5-1
	Adding Virtual Trunks	5-3
	BPX Management	5-5
	IP Setup and IP Relay Configuration (Preliminary)	5-5
	Installing SV+ and Associated Applications	5-5
	Configure SV+ Workstation (example)	5-5
	Network Node Configuration (Preliminary)	5-6

Adding nodes, adding trunks, shelves, etc. 5-6
Configuring the IPX, IGX, and BPX for SV+ NMS Operation 5-7
Configuring the AXIS for SV+ NMS Operation (example) 5-7

Chapter 5 Repair and Replacement 6-1

Preventive Maintenance 6-1
Troubleshooting the BPX 6-1
 General Troubleshooting Procedures 6-1
 Displaying the Status of Cards in the Node 6-4
Replacing Parts 6-5
 Replacing a Front Card 6-5
 Replacing a Line Module 6-7
 Replacing a DC Power Entry Module 6-9
 Replacing an AC Power Supply 6-11
 Field-Installing a Second AC Power Supply 6-12
 Replacing the Fan Assembly 6-14
 Replacing the Temperature Sensing Unit 6-15
 Replacing Card Slot and Fan Fuses on the System Backplane 6-15

Chapter 6 Frame Relay to ATM Network and Service Interworking 7-1

Service Interworking 7-3
Networking Interworking 7-4
ATM Protocol Stack 7-7
AIT/BTM Interworking and the ATM Protocol Stack 7-8
AIT/BTM Control Mapping, Frames and Cells 7-10
Management, OAM Cells 7-11
Functional Description 7-11
 ATF Summary 7-11
 Features 7-11
 Limitations 7-11
 Some ATF Connection Criteria 7-12
 Connection Management 7-12
 Port Management 7-12
 Structure 7-13
 Channel Statistics 7-13
 OAM Cell Support 7-14
 Diagnostics 7-14
 User Commands 7-15
 Virtual Circuit Features 7-15
 User Commands 7-16
 AUser Commands 7-16
Management 7-16
 Connection Management 7-16
 Routing 7-17
 Bandwidth Management 7-17

	User Interface	7-17
	Port Management	7-17
	Connection Management	7-18
	Signaling	7-18
	Alarms	7-18
Chapter 7	Tiered Networks	8-1
	Routing Hubs and Interface Shelves	8-1
	BPX Routing Hubs in a Tiered Network	8-3
	Tiered Network Implementation	8-3
	General	8-4
	Definitions	8-4
	Upgrades	8-4
	Co-locating Routing Hubs and Interface Shelves	8-5
	Network Management	8-5
	ForeSight	8-6
	Preferred Routing	8-6
	Local and Remote Loopbacks	8-6
	Testcon and Testdly	8-6
	IPX Interface Shelf Description	8-6
	Configuration and Management	8-7
	Interface Shelf Management	8-7
	Alarm Management of Interface Shelf on the BPX Hub Node	8-7
	Alarm Management on the IPX Interface Shelf	8-8
	Port Management	8-8
	Connection Management	8-8
	Bandwidth Management	8-8
	Statistics	8-8
	StrataView Plus NMS	8-9
Chapter 8	BPX SNMP Agent	9-1
	Introduction	9-1
	SNMP Overview	9-1
	SNMP Functions	9-3
	Responses to Get (Get-Next) Requests	9-4
	ATM Set Requests	9-4
	Responses to Set Requests	9-5
	MIB II Support	9-5
	StrataCom Proprietary MIB Structure	9-6
	Switch Service Objects	9-6
	Switch Connections	9-6
	Bandwidth Class	9-7
	Endpoint Statistics	9-7
	Endpoint Mapping	9-7
Appendix A	BPX Node Specifications	A-1
	General	A-1

ATM Trunk Interface (BXM-T3/E3 Cards)	A-3
ATM Trunk Interface (BXM-155 Cards)	A-4
ATM Trunk Interface (BXM-622 Cards)	A-5
ATM T3 Trunk Interface (BNI-T3, LM-3T3)	A-6
ATM E3 Trunk Interface (BNI-E3, LM-3E3)	A-7
ATM OC3 Trunk Interface (BNI-OC3, LM-OC3)	A-8
ATM Service Interface (BXM-T3/E3 Cards)	A-9
ATM Service Interface (BXM-155 Cards)	A-9
ATM Service Interface (BXM-622 Cards)	A-9
ATM Service Interface (ASI-1, LM-2T3)	A-10
ATM Service Interface (ASI-1, LM-2E3)	A-10
ATM Service Interface (ASI-2, LM-OC3)	A-11

Appendix B BPX Cabling Summary B-1

Trunk Cabling	B-1
Power Cabling	B-1
AC Powered Nodes	B-1
DC Powered Nodes	B-2
LM-BCC Cabling	B-2
Auxiliary and Control Port Cabling	B-2
LAN Port Cabling	B-3
Modem Cabling	B-3
External Clock Input Cabling	B-4
T1 Clock Cabling	B-4
E1 Clock Cabling	B-5
External Alarm Cabling	B-6
Standard BPX Cables	B-6
Redundancy “Y” Cable	B-7

Appendix C BPX Peripherals Specifications C-1

Network Management	C-1
StrataView Plus Terminal	C-1
Control Port, Local Control	C-1
Printer	C-2
DIP Switch Settings for Okidata 184	C-3
Modems, Dial-In and Dial-Out	C-5
Motorola V.34R BPX Dial-In Configuration	C-5
BPX Auto-Answer (Dial-In to BPX)	C-5
IPX Auto-Dial to Customer Service	C-7

Appendix D AT3-6ME Interface Adapter D-1

Application	D-1
General Description	D-1
Equipment Description	D-2
Interface Connectors	D-2
Front Panel Indicators	D-4
DIP Switches	D-4
Installation	D-6
System Connections	D-6
AT3-6ME Configuration	D-6
BPX or IPX Port Configuration	D-7
Operation	D-7
Power-Up Sequence	D-8
Normal Operation	D-8
Remote Loop Operation	D-8
Terminal Operation	D-9
Commands	D-9
Specifications	D-10
T3 interface	D-10
T2 Interface	D-11
Power	D-11
Mechanical	D-11
Terminal Interface	D-11

Appendix E Glossary 1

Index

- Figure 1-1** BPX General Configuration Example 24
- Figure 1-2** Frame Relay to ATM Network Interworking 30
- Figure 1-3** Frame Relay to ATM Service Interworking 31
- Figure 1-4** Tiered Network with BPX and IGX Routing Hubs 32
- Figure 1-5** Virtual Trunking Example 34
- Figure 2-1** A BPX Network with BXM Cards 3-2
- Figure 2-2** BXM-622 Front Panel, Two-Port Card Shown 3-8
- Figure 2-3** BXM-155 Front Panel, Eight-Port Card Shown 3-9
- Figure 2-4** BXM-T3/E3 Front Panel, 12-Port Card Shown 3-10
- Figure 2-5** SMF-622-2, SMFLR-622-2, and SMFXLR-622-2 Back Card 3-12
- Figure 2-6** BXM-155-8 Port Backcard, MMF, SMF, or SMFLR 3-13
- Figure 2-7** BPX-T3/E3 Back Card, 12-Port Option Shown 3-14
- Figure 2-8** Y-Cabling of SMF-622 Series Backcards 3-15
- Figure 2-9** BXM Port (Access UNI) Ingress Operation 3-17
- Figure 2-10** BXM Port (Access, UNI) Egress Operation 3-18
- Figure 2-11** BXM Trunk Ingress Operation 3-19
- Figure 2-12** BXM Trunk Egress Operation 3-20
- Figure 2-13** SONET Section, Line, and Path 3-26
- Figure 2-14** ASI cnfport Command 3-41
- Figure 2-15** ASI cnfportq Command 3-42
- Figure 2-16** BXM cnfport Command 3-44
- Figure 2-17** BXM cnfportq Command 3-45
- Figure 2-18** BNI cnftrk Command 3-46
- Figure 2-19** BNI cnftrkparm Command 3-47
- Figure 2-20** BXM cnftrk Command 3-48
- Figure 2-21** BXM cnftrkparm Command 3-49
- Figure 3-1** ATM Connections over a BPX Network 4-2
- Figure 3-2** ABR VSVD Flow Control Diagram 4-5
- Figure 3-3** CBR Connection Prompt Sequence 4-14
- Figure 3-4** VBR Connection Prompt Sequence 4-15
- Figure 3-5** ATFR Connection Prompt Sequence 4-17
- Figure 3-6** ABR Standard Connection Prompt Sequence 4-19
- Figure 3-7** Meaning of VSVD and Flow Control External Segments 4-20
- Figure 3-8** ABR ForeSight Connection Prompt Sequence 4-21

Figure 3-9	ATFST Connection Prompt Sequence	4-22
Figure 3-10	UBR Connection Prompt Sequence	4-23
Figure 4-1	Virtual Trunks across a StrataCom ATM Cloud	5-4
Figure 4-2	SV+ Physical LAN and IP Relay Network	5-5
Figure 5-1	Unlatching the Air Intake Grille	6-7
Figure 5-2	Removing a Line Module	6-9
Figure 5-3	DC Power Entry Module with Conduit Box	6-10
Figure 5-4	AC Power Supply Assembly	6-11
Figure 5-5	Removing Blank Filler Panel (B side shown)	6-12
Figure 5-6	Card Slot and Fan Fuse Locations on System Backplane	6-16
Figure 6-1	Frame Relay to ATM Network Interworking	7-2
Figure 6-2	Frame Relay to ATM Service Interworking	7-2
Figure 6-3	Frame Relay to ATM Interworking Examples with AIT Card on IPX	7-3
Figure 6-4	Frame Relay to ATM Service Interworking Detail	7-4
Figure 6-5	Frame Relay to ATM NW Interworking Detail	7-5
Figure 6-6	ATF Connections, Simplified Example	7-6
Figure 6-7	ATM Layers	7-7
Figure 6-8	Protocol Stack Operation	7-9
Figure 7-1	Tiered Network with BPX and IGX Routing Hubs	8-2
Figure 7-2	Tiered Network with BPX Routing Hubs	8-3
Figure 7-3	SV+ Connection Manager	8-9
Figure 8-1	SNMP Manager and Agents in a BPX Domain	9-2
Figure C-1	Dial-Modem Cabling for Auto Answer (Dial-In to BPX)	C-7
Figure C-2	Dial Modem Cabling for Auto Dial (dial-out to customer service)	C-9
Figure D-1	Network Application	D-1
Figure D-2	Front and Rear Panel Features	D-5

Table 2-1	BXM-155 and BXM 622 Front Card Options	3-3
Table 2-2	BXM-155 and BXM-622 Back Cards	3-4
Table 2-3	BXM Front Panel Status Indicators	3-7
Table 2-4	BXM Front Panel Card Failure Indications	3-7
Table 2-5	BXM-622 Backcards	3-11
Table 2-6	BXM-155 Backcards	3-11
Table 2-7	BXM-T3/E3 Backcards	3-11
Table 2-8	Fiber Optic Interface Characteristics OC12	3-25
Table 2-9	Fiber Optic Interface Characteristics OC3	3-25
Table 2-10	SONET Section, Line, and Path Descriptions	3-26
Table 2-11	Digital Hierarchies	3-27
Table 3-1	Standard ATM Traffic Classes	4-3
Table 3-2	Traffic Policing Definitions	4-9
Table 3-3	Connection Parameters with Default Settings and Ranges	4-10
Table 3-4	Connection Parameter Descriptions	4-12
Table 3-5	CBR Policing Definitions	4-14
Table 3-6	VBR Policing Definitions	4-16
Table 3-7	UBR Policing Definitions	4-23
Table 3-8	ILMI Parameters	4-24
Table 3-9	LMI Parameters	4-24
Table 5-1	Troubleshooting the BPX Node	6-2
Table 5-2	Card Status for the BPX	6-4
Table A-1	Ambient Temperature and Humidity Limits	A-2
Table B-1	Trunk Cables	B-1
Table B-2	AC Power Cables	B-2
Table B-3	DC Power Wiring	B-2
Table B-4	Auxiliary and Control Port Cabling	B-2
Table B-5	Auxiliary and Control Port Pin Assignments	B-3
Table B-6	LAN Port Cabling	B-3
Table B-7	LAN Port Pin Assignments	B-3
Table B-8	External Clock Cabling	B-4
Table B-9	T1 Connection to XFER TMG on BCC-bc	B-4
Table B-10	T1 Connection to EXT TMG on BCC-bc	B-4
Table B-11	T1 Connection to EXT 1 or EXT 2 on BCC-3-bc	B-4

Table B-12	E1 Connector Pin Assignments for External Clock	B-5
Table B-13	E1 Connection 75 Ohm to EXT TMG on BCC-bc or BCC-3-bc	B-5
Table B-14	E1 Connection 100/120 Ohm to EXT TMG on BCC-bc	B-5
Table B-15	E1 Connection 100/120 Ohm to EXT 1 or EXT 2 on BCC-3-bc	B-5
Table B-16	External Alarm Cabling	B-6
Table B-17	Network Alarm Pin Assignments	B-6
Table B-18	Standard Cables	B-7
Table B-19	Redundancy Y-Cables	B-7
Table C-1	Control Port Parameters for Local Control (pc or workstation)	C-2
Table C-2	Auxiliary Port Parameters for OkiData 184 Printer	C-2
Table C-3	Switch A Settings—Okidata 184 Printer	C-3
Table C-4	Switch 1 Settings—Okidata 184 Printer	C-4
Table C-5	Switch 2 Settings—Okidata 184 Printer	C-4
Table C-6	Modem Interface Requirements	C-5
Table C-7	V.34R Modem Configuration for Auto-Answer (Dial-in to BPX)	C-6
Table C-8	V.34R Auto-Dial Configuration (dial-out to customer service)*	C-8
Table C-9	V.34R with talk/data, Auto-Dial Configuration (dial-out to customer service)*	C-8
Table D-1	Rear Panel Connectors	D-3
Table D-2	Front Panel Indicators	D-4
Table D-3	DIP Switch SW-1 Selection Guide	D-6
Table D-4	DIP Switch SW-2 Selection Guide	D-7
Table D-5	Alarm Handling	D-8
Table D-6	DIP Switch Settings	D-9
Table D-7	Command Summary	D-9
Table D-8	Status Display	D-10



About this Publication

This publication provides an overview of the operation of the BPX Service Node.

Cisco documentation and additional literature are available in a CD-ROM package, which ships with your product. The Documentation CD-ROM, a member of the Cisco Connection Family, is updated monthly. Therefore, it might be more up to date than printed documentation. To order additional copies of the Documentation CD-ROM, contact your local sales representative or call customer service. The CD-ROM package is available as a single package or as an annual subscription. You can also access Cisco documentation on the World Wide Web at <http://www.cisco.com>, <http://www-china.cisco.com>, or <http://www-europe.cisco.com>.

Objectives

This publication is intended to provide reference information useful during installation, configuration, operation, and maintenance of the BPX Service Node.

Audience

This publication is intended for installers, operators, network designers, and system administrators.

Organization

This publication is organized as follows:

- | | |
|------------------|---|
| Chapter 1 | Introduction
Describes the overall operation of the BPX Service Node and associated peripherals. |
| Chapter 2 | General Description
Provides an overall physical and functional description of the BPX. The physical description includes the BPX enclosure, power, and cooling subsystems. The functional description includes an overview of BPX operation. |
| Chapter 3 | BPX Common Core
Describes the common core group, comprising the Broadband Controller Cards (BCCs), the Alarm/Status Monitor (ASM) card, associated backcards, and the StrataBus backplane. |
| Chapter 4 | Network Interface (Trunk) Cards
Describes the BPX network interface (trunk) cards, including the Broadband Network Interface (BNI) and associated backcards. The BXM card trunk operation is briefly described in this chapter with additional information provided in <i>Chapter 2</i> . |
| Chapter 5 | Service Interface (Line) Cards
This chapter contains a description of the BPX service interface (line) cards, including the ATM Service Interface (ASI) and associated backcards. The BXM card service (port UNI) operation is briefly described in this chapter with additional information provided in <i>Chapter 2</i> . |
| Chapter 2 | BXM T3/E3, 155, and 622
Describes the BXM card group which includes the BXM-T3/E3, BXM-155 and BXM-622 card sets. Describes the operation of these cards in either trunk or service (port UNI) mode. |
| Chapter 3 | ATM Connections
Describes how ATM connection services are established by adding ATM connections between ATM service interface ports in the network using ATM standard UNI 3.1 and Traffic Management 4.0. It describes BXM and ASI card operation and summarizes ATM connection parameter configuration. |
| Chapter 4 | Configuration and Management
Provides preliminary configuration overview for configuring a BPX Service Node and an AXIS. |
| Chapter 5 | Repair and Replacement
Describes periodic maintenance procedures, troubleshooting procedures, and the replacement of major BPX components. |

-
- Chapter 6** **Frame Relay to ATM Network and Service Interworking**
- Describes frame relay to ATM interworking which allows users to retain their existing Frame Relay services, and as their needs expand, migrate to the higher bandwidth capabilities provided by BPX ATM networks. Frame Relay to ATM Interworking enables frame relay traffic to be connected across high-speed ATM trunks using ATM standard Network and Service Interworking.
- Chapter 7** **Tiered Networks**
- Describes the tiered network configuration that provides the capability of adding interface shelves/feeders (non-routing nodes) to an IPX/IGX/BPX routing network.
- Chapter 8** **BPX SNMP Agent**
- Introduces the functions of the Simple Network Management Protocol (SNMP) agent and MIBs that are embedded in each BPX node.
- Appendix A** **BPX Node Specifications**
- Lists the BPX Service Node specifications.
- Appendix B** **BPX Cabling Summary**
- Provides details on the cabling required to install the BPX Service Node.
- Appendix C** **BPX Peripherals Specifications**
- Provide details on the specifications for peripherals used with the BPX Service Node.
- Appendix D** **AT3-6ME Interface Adapter**
- Describes the AT3-6M Interface Adapter, sometimes referred to as the T3-T2 Interface Adapter, that may be used with the BPX Service Node to provide a 6 Mbps ATM network interface to T2 transmission facilities.
- Glossary**

Related Documentation

The following Cisco StrataCom publications contain additional information related to the installation and operation of the BPX Service Node and associated equipment in a BPX, IGX, IPX network:

- *StrataView Plus Operations Guide* providing for procedures for using the StrataView Plus network management system.
- StrataSphere Network Design Tools providing procedures for modeling networks.
- Release 8.5 of the IGX/IPX/BPX Documentation set, including:
 - *BPX Reference* providing a general description and technical details of the BPX broadband node.
 - *IPX Reference* providing a general description and technical details of the IPX narrowband node.
 - *IPX Installation* providing installation instructions for the IPX.
 - *IGX Reference* providing a general description and technical details of the IGX node.
 - *IGX Installation* providing installation instructions for the IGX.
 - *AXIS Reference* providing a general description and technical details of the AXIS node.
 - *AXIS Command Reference* providing detailed information for AXIS command line usage.
 - *Command Reference* providing detailed information on operating the BPX, IGX, and IPX systems through their command line interfaces.
 - *SuperUser Command Reference* providing detailed information on their command line interfaces special commands requiring SuperUser access authorization.

Conventions

This publication uses the following conventions to convey instructions and information.

Command descriptions use these conventions:

- Commands and keywords are in **boldface**.
- Arguments for which you supply values are in *italics*.
- Elements in square brackets ([]) are optional.
- Alternative but required keywords are grouped in braces ({ }) and are separated by vertical bars (|).
- Examples use these conventions:
 - Terminal sessions and information the system displays are in `screen font`.
 - Information you enter is in **boldface screen font**.
 - Nonprinting characters, such as passwords, are in angle brackets (< >).
 - Default responses to system prompts are in square brackets ([]).

Note Means *reader take note*. Notes contain helpful suggestions or references to materials not contained in this manual.



Timesaver Means *the described action saves time*. You can save time by performing the action described in the paragraph.



Caution Means *reader be careful*. In this situation, you might do something that could result in equipment damage or loss of data.



Warning This warning symbol means *danger*. You are in a situation that could cause bodily injury. Before you work on any equipment, you must be aware of the hazards involved with electrical circuitry and familiar with standard practices for preventing accidents. (To see translated versions of this warning, refer to the *Regulatory Compliance and Safety Information* that accompanied your equipment.)

Introduction

This chapter contains an overall description of the BPX Service Node. For installation information, refer to the *BPX Service Node Installation Manual*. For additional information on BPX Service Node operation and configuration, refer to the Release 8.5 *Cisco StrataCom System Overview* and *Command Reference* documents.

This chapter contains the following:

- General Description
- New with Release 8.5
- New with Release 8.4
- Continuing Features with Release 8.5 and 8.4
- BPX Operation
- Traffic and Congestion Management
- Network Management
- Node Availability

General Description

The BPX Service Node is a standards based high-capacity broadband ATM switch that provides backbone ATM switching and delivers a wide range of user services (Figure 1-1).

BPX Capabilities

Fully integrated with the AXIS, IPX, and IGX, the BPX Service Node is a scalable, standards-compliant unit. Using a multi-shelf architecture, the BPX Service Node supports both narrowband and broadband user services. The modular, multi-shelf architecture enables users to incrementally expand the capacity of the system as needed. The BPX Service Node consists of the BPX broadband shelf with fifteen card slots and co-located AXIS, and ESP (Extended Services Processor), as required.

Three of the slots on the BPX shelf are reserved for common equipment cards. The other twelve are general purpose slots used for network interface cards or service interface cards. The cards are provided in sets, consisting of a front card and associated back card. The BPX shelf can be mounted in a rack enclosure, which provides mounting for a co-located Extended Service Processor (ESP) and AXIS Interface Shelves.

Figure 1-1 BPX General Configuration Example

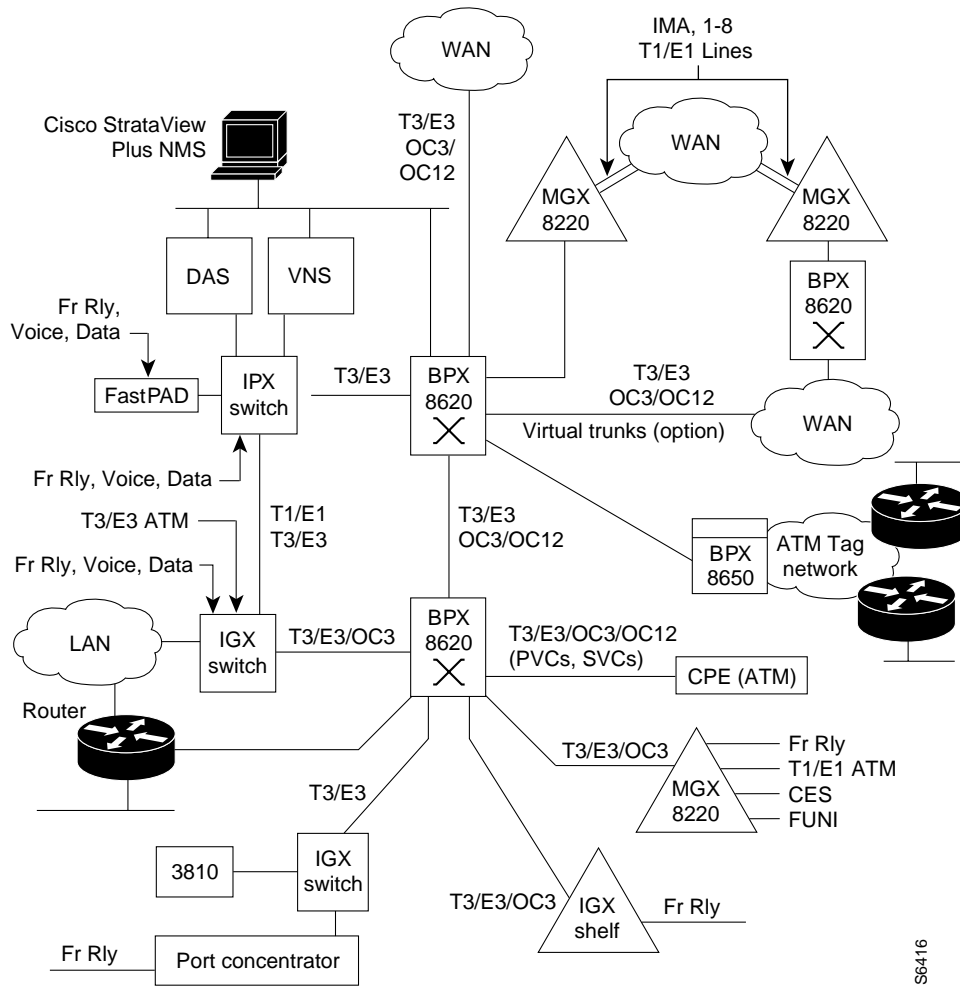

S6416

Extended Services Processor

With a co-located Extended Services Processor (ESP), the BPX Service Node adds the capability to support ATM and frame relay Switch Virtual Circuits (SVCs).

Access Devices

The AXIS interface shelf supports a wide range of economical narrowband interfaces. It converts all non-ATM traffic into 53-byte ATM cells and concentrates this traffic for high speed switching by the BPX. The AXIS provides a broad range of narrowband user interfaces. Release 4 of the AXIS provides T1/E1 and subrate frame relay, FUNI (Frame Based UNI over ATM), T1/E1 ATM, T1/E1 Circuit Emulation Service (CES), HSSI and X.21 interfaces and SRM-3T3 enhancements, and frame relay to ATM network and service interworking for traffic over the ATM network via the BPX.

The IPX may be configured as a shelf and used as a low-cost Frame Relay to ATM interworking concentrator for the BPX. The IPX may also be configured as a co-located shelf and used as an economical ATM service input to the BPX. The IGX may also be configured as an interface shelf to the BPX.

New with Release 8.5

Network

- Support for IGX hubs and associated interface shelves in tiered network
- The number of nodes supported in a network is increased to over 1100, of which 223 can be routing nodes.

AXIS

- AXIS supports up to 12 StrataView Plus workstations

StrataSphere Network Management

- StrataSphere NMS enhancements including additional management and provisioning capabilities including support of IGX tiered network voice and data applications
- Support for 12 StrataView Plus workstations
- Multi-network StrataView Plus capability

IGX

- The IGX is configurable as a tiered network routing hub supporting voice and data over IGX interface shelves.
- IGX supports 32 trunks
- IGX supports 2750 virtual connections

New with Release 8.4

- The BXM cards provide a range of trunk and service interfaces and support ATM Forum Standards UNI 3.1 and ATM Traffic Management 4.0 including ABR connections with VS/VD congestion control. The BXM cards are implemented with Stratm technology which uses a family of custom Application Specific Integrated Circuits (ASICs) to provide high-density, high-speed operation. The three types of BXM cards are:
 - The BXM T3/E3 is available as an eight or twelve port card that provides T3/E3 interfaces at 44.736 or 34.368 Mbps rates, respectively. The BXM-T3/E3 can be configured for either trunk or access applications.
 - The BXM 155 is available as a four or eight port card that provides OC-3/STM-1 interfaces at 155.52 Mbps rates. The BXM-155 can be configured for either trunk or access applications.

- The BXM 622 is available as a one or two port card that provides OC-12/STM-4 interfaces at 622.08 Mbps rates. The BXM-622 can be configured for either trunk or access applications.
- Enhanced network scaling:
 - 50/64 trunks per BPX equipped with BCC-32 or BCC-64, respectively
 - 72/144 lines per node equipped with BCC-32 or BCC-64, respectively
 - 223 routing nodes (with BPX or IGX)
 - trunk based loading
 - BCC-3-64
 - 7000 virtual connections (BCC-3-32)
 - 12000 virtual connections (BCC-3-64)
 - de-route delay timer
 - connection routing groups by cell loading
- ATM and Frame Relay SVCs with Extended Services Processor

The Extended Services Processor (ESP) is an adjunct processor that is co-located with a BPX Service Node. The ESP provides the signaling and Private Network to Network Interface (PNNI) routing for ATM and Frame Relay switched virtual circuits (SVCs) via BXM cards in the BPX and AUSM and FRSM cards in the AXIS.
- StrataSphere NMS enhancements including additional management and provisioning capabilities.
- BCC-3-64
- BCC-4 supporting 19.2 Gbps switching with the BXM cards supporting egress at up to 1600 Mbps and ingress at up to 800 Mbps.
- BXM cards support egress at up to 1600 Mbp and ingress at up to 800 Mbps
- Hot Standby Redundancy
- Axis Release 4.0, which will include:
 - BNM-155 interface to BXM on BPX
 - FRSM support for both SVC and PVC frame relay connections with ESP
 - AUSM support for both SVC and PVC ATM connections with ESP
 - FRSM-8 with ELMI
 - IMATM-B
 - AUSM-8
 - CESM/4T1E1
 - FRSM-HS1 (HSSI and X.21 interfaces)
 - SRM 3T3
- Access Products
 - FastPAD MM and MP
 - Cisco 3800

Continuing Features with Release 8.5 and 8.4

The following is a list of previously provided features that are included in Release 8.4 along with the new features previously listed:

StrataSphere Network Management

- StrataSphere frame relay connection and AXIS equipment management by the SV+ Connection Manager and Equipment Manager.
- SNMP Enhancements for connection management and monitoring
- Support for Solaris 2.5.1

Network

- IMA (Inverse Multiplexing ATM)
- Frame Relay to ATM Network Interworking (Supported by FRP on IPX, FRM on IGX, and FRSM on AXIS).
- Frame Relay to ATM Service interworking (Supported by FRSM on AXIS)
- Tiered networks
- Automatic end-to-end routing of virtual connections (AutoRoute)
- Closed-loop, rate-based congestion management (using ForeSight for ABR).
- Effective management of quality of service (OptiClass)
- Per -VC queueing and per-VC scheduling (FairShare)

BPX Service Node

- Virtual Trunking
- IMA (Inverse Multiplexing ATM)
- Enhanced Ingress buffers for ASI-155 and BNI-155 to 8K cells for Release 8.1 and up
- BPX OC3 network and service interfaces on the BNI and ASI cards, respectively
- High-speed switching capacity
- Powerful crosspoint switching architecture
- 53-byte cell-based ATM transmission protocol
- Twelve 800 Mbps switch ports for network or access interfaces with BNI and ASI cards respectively.
- Three DS3 or E3 ATM network interface ports per card (BNI)
- Totally redundant common control and switch fabric
- Up to 20 million point-to-point cell connections per second between slots
- Switches individual connections rather than merely serving as a virtual path switch
- Easy integration into existing IPX and IGX networks
- Internal diagnostics and self-test routines on all cards and backplane, status indication on each card

- Collection of many ATM and other network statistics and transfer of the data collected to StrataView Plus over high-speed Ethernet LAN interface
- Integration with the StrataView Plus Network Management System to provide configuration, control, and maintenance
- Conformation to recommendations from all current ATM standards bodies: ATM Forum, ITU, ETSI, and ANSI
- Compliant with all applicable safety, emissions, and interface regulations. Meets requirements of NEBS for Central Office equipment

AXIS

- IMA (Inverse Multiplexing ATM) support for the BPX with Rel. 3 AXIS
- CES T1/E1
- AXIS T1/E1 frame relay and T1/E1 ATM service interfaces
- FUNI (Frame Based UNI over ATM)

BPX Operation

A BPX node is a self-contained chassis which may be rack-mounted in a standard 19-inch rack or open enclosure. All control functions, switching matrix, backplane connections, and power supplies are redundant, and non-disruptive diagnostics continuously monitor system operation to detect any system or transmission failure. Hot-standby hardware and alternate routing capability combine to provide maximum system availability.

The BPX Service Node with AXIS Shelves

Many network locations have increasing bandwidth requirements due to emerging applications. To meet these requirements, users can overlay their existing narrowband networks with a backbone of BPX nodes to utilize the high-speed connectivity of the BPX operating at 19.2 Gbps with its T3/E3/OC3/OC12 network and service interfaces. The BPX service interfaces include BXM and ASI ports on the BPX and service ports on AXIS shelves. The AXIS shelves may be co-located in the same cabinet as the BPX, providing economical port concentration for T1/E1 Frame Relay, T1/E1 ATM, CES, and FUNI connections.

The BPX Service Node with ESP

With a co-located Extended Services Processor (ESP), the BPX Service Node adds the capability to support ATM and frame relay Switched Virtual Circuits (SVCs).

BPX Switching

With the BCC-4 the BPX employs a 19.2 Gbps crosspoint switch matrix for cell-based switching. The switch matrix provides total, non-blocking bandwidth for point-to-point cell switching of up to 20 million point-to-point connections per second between slots for cell-switching. It is designed to easily meet current requirements with scalability to higher capacity for future growth.

With the BCC-4, the BPX employs a redundant 19.2 Gbps non-blocking crosspoint switch matrix for cell switching. The switch matrix can establish up to 20 million point-to-point connections per second between ports. A single BPX provides twelve card slots, with each card capable of operating

at 800 Mbps for ASI and BNI cards. The BXM cards support egress at up to 1600 Mbps and ingress at up to 800 Mbps. Access to and from the crosspoint switch is through multi-port network and user access cards.

A BPX shelf is a self-contained chassis which may be rack-mounted in a standard 19-inch rack or open enclosure. All control functions, switching matrix, backplane connections, and power supplies are redundant, and non-disruptive diagnostics continuously monitor system operation to detect any system or transmission failure. Hot-standby hardware and alternate routing capability combine to provide maximum system availability.

Frame Relay to ATM Interworking

Interworking allows users to retain their existing services, and as their needs expand, migrate to the higher bandwidth capabilities provided by BPX ATM networks. Frame Relay to ATM Interworking enables frame relay traffic to be connected across high-speed ATM trunks using ATM standard Network and Service Interworking

Two types of Frame Relay to ATM interworking are supported, Network Interworking (Figure 1-2) and Service Interworking (Figure 1-3). The Network Interworking function is performed by the AIT card on the IPX, the BTM card on the IGX, and the FRSM card on the AXIS. The FRSM card on the AXIS and the UFM cards on the IGX also support Service Interworking.

The frame relay to ATM network and service interworking functions are available as follows:

Network Interworking

Part A of Figure 1-2 shows typical frame relay to network interworking. In this example, a frame relay connection is transported across an ATM network, and the interworking function is performed by both ends of the ATM network. The following are typical configurations:

- IGX or IPX frame relay (shelf/feeder) to IGX or IPX frame relay (either routing node or shelf/feeder)
- AXIS frame relay to AXIS frame relay
- AXIS frame relay to IGX or IPX frame relay (either routing node or shelf/feeder)

Part B of Figure 1-2 shows a form of network interworking where the interworking function is performed by only one end of the ATM network, and the CPE connected to the other end of the network must itself perform the appropriate service specific convergence sublayer function. The following are example configurations:

- IGX or IPX frame relay (either routing node or shelf/feeder) to BPX or AXIS ATM port.
- AXIS frame relay to BPX or AXIS ATM port.

Network Interworking is supported by the FRP on the IPX, the FRM, UFM-C, and UFM-U on the IGX, and the FRSM on the AXIS. The Frame Relay Service Specific Convergence Sublayer (FR-SSCS) of AAL5 is used to provide protocol conversion and mapping.

Figure 1-2 Frame Relay to ATM Network Interworking

Part A

Network interworking connection from CPE Frame Relay port to CPE Frame Relay port across an ATM Network with the interworking function performed by both ends of the network.

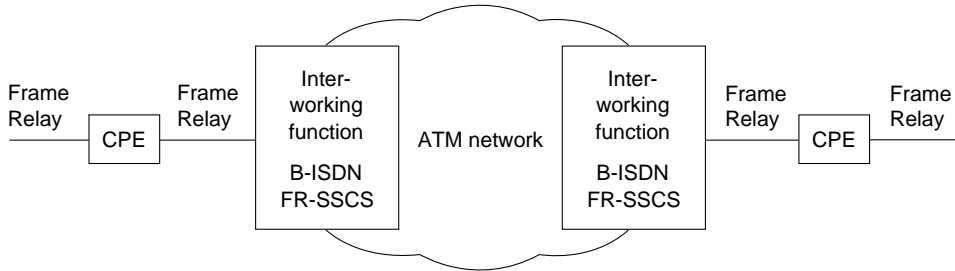

Part B

Network interworking connection from CPE Frame Relay port to CPE ATM port across an ATM network, where the network performs an interworking function only at the Frame Relay end of the network. The CPE receiving and transmitting ATM cells at its ATM port is responsible for exercising the applicable service specific convergence sublayer, in this case, (FR-SSCS).

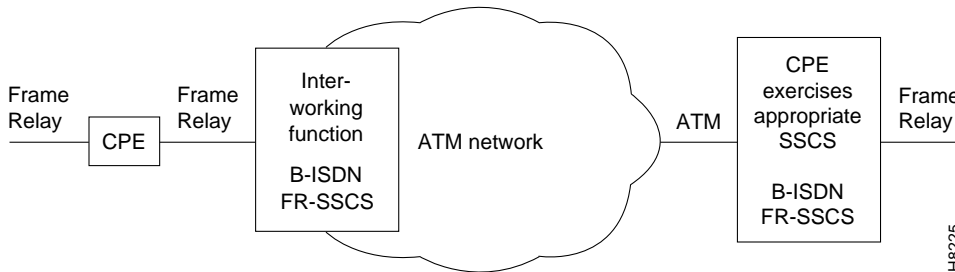

Service Interworking

Figure 1-3 shows a typical example of Service Interworking. Service Interworking is supported by the FRSM on the AXIS and the UFM-C and UFM-U on the IGX. Translation between the Frame Relay and ATM protocols is performed in accordance with RFC 1490 and RFC 1483. The following is a typical configuration for service interworking:

- AXIS Frame Relay (FRSM card) to BPX or AXIS ATM port.
- IGX Frame Relay (FRM-U or FRM-C) to BPX or AXIS ATM port.

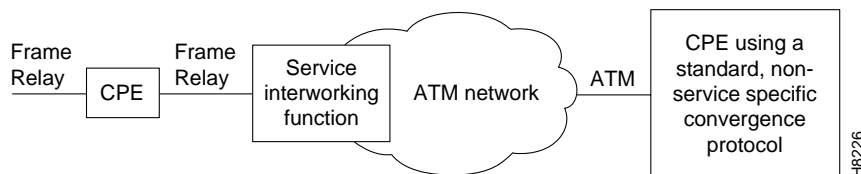
Figure 1-3 Frame Relay to ATM Service Interworking

Additional Information

For additional information about interworking, refer to **Chapter 6**, Frame Relay to ATM Network and Service Interworking.

Tiered Networks

Networks may be configured as flat (all nodes perform routing and communicate fully with one another), or they may be configured as tiered. In a tiered network interface shelves are connected to routing hubs, where the interface shelves are configured as non-routing nodes.

By allowing CPE connections to connect to a non-routing node (interface shelf), a tiered network is able to grow in size beyond that which would be possible with only routing nodes comprising the network.

With Release 8.5, in addition to BPX routing hubs, tiered networks now support IGX routing hubs. Voice and data connections originating and terminating on IGX interface shelves (feeders) are routed across the routing network via their associated IGX routing hubs. Intermediate routing nodes must be IGX nodes, and IGX interface shelves are the only interface shelves that can be connected to an IGX routing hub. With this addition, a tiered network can now provide a multi-service capability (frame relay, circuit data, voice, and ATM).

Routing Hubs and Interface Shelves

In a tiered network, interface shelves at the access layer (edge) of the network are connected to routing nodes via feeder trunks (Figure 1-4). Those routing nodes with attached interface shelves are referred to as routing hubs. The interface shelves, sometimes referred to as feeders, are non-routing nodes. The routing hubs route the interface shelf connections across the core layer of the network.

The interface shelves do not need to maintain network topology nor connection routing information. This task is left to their routing hubs. This architecture provides an expanded network consisting of a number of non-routing nodes (interface shelves) at the edge of the network that are connected to the network by their routing hubs.

BPX Routing Hubs

T1/E1 Frame Relay connections originating at IPX and IGX interface shelves and T1/E1 Frame Relay, T1/E1 ATM, CES, and FUNI connections originating at AXIS interface shelves are routed across the routing network via their associated BPX routing hubs.

The following requirements apply to BPX routing hubs and their associated interface shelves:

- Only one feeder trunk is supported between a routing hub and interface shelf.
- No direct trunking between interface shelves is supported.
- No routing trunk is supported between the routing network and interface shelves.

- The feeder trunks between BPX hubs and IPX or IGX interface shelves are either T3 or E3.
- The feeder trunks between BPX hubs and AXIS interface shelves are T3, E3, or OC3-c/STM-1.
- Frame Relay connection management to an IPX or IGX interface shelf is provided by StrataView Plus.
- Frame Relay and ATM connection management to an AXIS interface shelf is provided by StrataView Plus
- Telnet is supported to an interface shelf; the vt command is not.
- Frame Relay connections originating at IGX interfaces shelves connected to IGX routing hubs may also be routed across BPX intermediate nodes.
- Remote printing by the interface shelf via a print command from the routing network is not supported.

Figure 1-4 Tiered Network with BPX and IGX Routing Hubs

IMA (Inverse Multiplexing ATM)

Where greater bandwidths are not needed, the Inverse Multiplexing ATM (IMA) feature provides a low cost trunk between two BPXs. The IMA feature allows BPX nodes to be connected to one another over from 1 to 8 T1 or E1 trunks provided by an AIMNM module on an AXIS Shelf. A BNI port on each BPX is directly connected to an AIMNM module in an AXIS shelf by a T3 or E3 trunk. The AIMNM modules are then linked together by from 1 to 8 T1 or E1 trunks. Refer to the *AXIS Reference* and the *Command Reference* manuals for further information.

Virtual Trunking

Virtual trunking provides the ability to define multiple trunks within a single physical trunk port interface. Virtual trunking benefits include the following:

- Reduced cost by configuring the virtual trunks supplied by the Public Carrier for only as much bandwidth as needed instead of at full T3, E3, or OC3 bandwidths.
- Utilization of the full mesh capability of the Public Carrier to reduce the number of leased lines needed between nodes in the StrataCom subnetworks.
- Or, choice of keeping existing leased lines between nodes, but using virtual trunks for backup.
- Ability to connect BNI trunk interfaces to a public network using standard ATM UNI cell format.
- Virtual trunking can be provisioned via either a Public ATM Cloud or a StrataCom ATM cloud.

A virtual trunk may be defined as a “trunk over a public ATM service”. The trunk really doesn’t exist as a physical line in the network. Rather, an additional level of reference, called a **virtual trunk number**, is used to differentiate the virtual trunks found within a physical trunk port. Figure 1-5 shows four StrataCom sub-networks, each connected to a Public ATM Network via a physical line. The Public ATM Network is shown linking all four of these subnetworks to every other one with a full meshed network of virtual trunks. In this example, each physical line is configured with three virtual trunks.

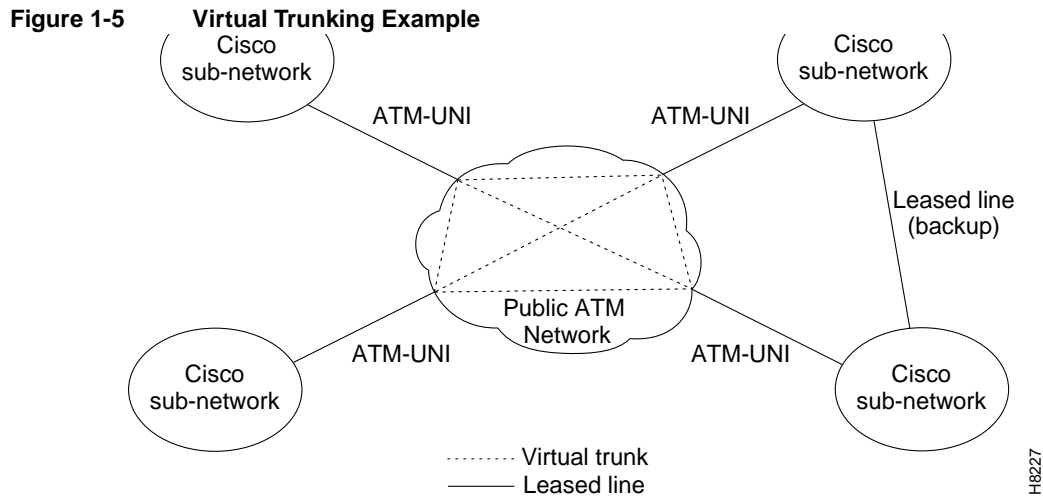

For further information on Virtual Trunking, refer to the *Systems Manual* and to the *Command Reference Manual*. For sample configuration information, refer to **Chapter 4**, Configuration and Management.

Traffic and Congestion Management

The BPX provides ATM standard traffic and congestion management per ATM Forum TM 4.0 using BXM cards.

The Traffic Control functions include:

- Usage Parameter Control (UPC)
- Traffic Shaping
- Connection Management Control:
- Selective Cell Discarding
- Explicit Forward Congestion Indication (EFCI)

In addition to these standard functions, the BPX provides advanced traffic and congestion management features including:

- Support for the full range of ATM service types per ATM Forum TM 4.0 by the BXM-T3/E3, BXM-155, and BXM-622 cards on the BPX Service Node.
- FairShare, dedicated queue and rate controlled servers for each VPC/VCC at the network ingress.
- OptiClass, guarantees QoS for individual connections by providing up to 32 queues with independent service algorithms for each trunk in the network.
- AutoRoute, end-to-end connection management that automatically selects the optimum connection path based upon the state of the network and assures fast automatic alternate routing in the event of intermediate trunk or node failures.
- PNNI, a standards based routing protocol for ATM and Frame Relay switched virtual circuits (SVCs).

- FBTC (Frame Based Traffic Control) for AAL5 connections, including early and partial frame discard.
- ForeSight, an end-to-end closed loop rate based congestion control algorithm that dynamically adjusts the service rate of VC queues based on network congestion feedback.
- ABR Standard with VSVD congestion control using RM cells and supported by BXM cards on the BPX Service Node.

FairShare

Fairshare provides per-VC queueing and per-VC scheduling. Fairshare provides fairness between connections and firewalls between connections. Firewalls prevent a single non-compliant connection from affecting the QoS of compliant connections. The non-compliant connection simply overflows its own buffer.

The cells received by a port are not automatically transmitted by that port out to the network trunks at the port access rate. Each VC is assigned its own ingress queue that buffers the connection at the entry to the network. With ABR with VSVD or with ForeSight, the service rate can be adjusted up and down depending on network congestion.

Network queues buffer the data at the trunk interfaces throughout the network according to the connections class of service. Service classes are defined by standards-based QoS. Classes can consist of the four broad service classes defined in the ATM standards as well as multiple sub-classes to each of the four general classes. Classes can range from constant bit rate services with minimal cell delay variation to variable bit rates with less stringent cell delay.

When cells are received from the network for transmission out a port, egress queues at that port provide additional buffering based on the service class of the connection.

OptiClass

OptiClass provides a simple but effective means of managing the quality of service defined for various types of traffic. It permits network operators to segregate traffic to provide more control over the way that network capacity is divided among users. This is especially important when there are multiple user services on one network.

Rather than limiting the user to the four broad classes of service initially defined by the ATM standards committees, OptiClass can provide up to thirty-two classes of service (service subclasses) that can be further defined by the user and assigned to connections. Some of the COS parameters that may be assigned include:

- Minimum bandwidth guarantee per subclass to assure that one type of traffic will not be preempted by another.
- Maximum bandwidth ceiling to limit the percentage of the total network bandwidth that any one class can utilize.
- Queue depths to limit the delay.
- Discard threshold per subclass.

These class of service parameters are based on the standards-based Quality of Service parameters and are software programmable by the user. The BPX provides separate queues for each traffic class.

AutoRoute

With AutoRoute, connections in StrataCom cell relay networks are added if there is sufficient bandwidth across the network and are automatically routed when they are added. The user only needs to enter the endpoints of the connection at one end of the connection and the IPX, IGX, and BPX software automatically set up a route based on a sophisticated routing algorithm. This feature is called *AutoRoute*. It is a standard feature on all StrataCom nodes.

System software automatically sets up the most direct route after considering the network topology and status, the amount of spare bandwidth on each trunk, as well as any routing restrictions entered by the user (e.g. avoid satellite links). This avoids having to manually enter a routing table at each node in the network. AutoRoute simplifies adding connections, speeds rerouting around network failures, and provides higher connection reliability.

PNNI

The Private Network to Network Interface (PNNI) protocol provides a standards-based dynamic routing protocol for ATM and frame relay switched virtual circuits (SVCs). PNNI is an ATM-Forum-defined interface and routing protocol which is responsive to changes in network resources, availability, and will scale to large networks. PNNI is available on the BPX Service Node when an Extended Services Processor (ESP) is installed. For further information about PNNI and the ESP, refer to the *Cisco StrataCom BPX Service Node Extended Services Processor Installation and Operation* document.

Congestion Management, VS/VD

The BPX/IGX/IPX networks provide a choice of two dynamic rate based congestion control methods, ABR with VS/VD and ForeSight. This section describes Standard ABR with VSVD.

Note ABR with VSVD is an optional feature that must be purchased and enabled on a single node for the entire network.

When an ATM connection is configured for Standard ABR with VSVD per ATM Forum TM 4.0, RM (Resource Management) cells are used to carry congestion control feedback information back to the connection's source from the connection's destination.

The ABR sources periodically interleave RM cells into the data they are transmitting. These RM cells are called forward RM cells because they travel in the same direction as the data. At the destination these cells are turned around and sent back to the source as Backward RM cells.

The RM cells contain fields to increase or decrease the rate (the CI and NI fields) or set it at a particular value (the explicit rate ER field). The intervening switches may adjust these fields according to network conditions. When the source receives an RM cell it must adjust its rate in response to the setting of these fields.

When spare capacity exists with the network, ABR with VSVD permits the extra bandwidth to be allocated to active virtual circuits.

Congestion Management, ForeSight

The BPX/IGX/IPX networks provide a choice of two dynamic rate based congestion control methods, ABR with VS/VD and ForeSight. This section describes ForeSight.

Note ForeSight is an optional feature that must be purchased and enabled on a single node for the entire network.

ForeSight may be used for congestion control across BPX/IGX/IPX switches for connections that have one or both end points terminating on other than BXM cards, for example ASI cards. The ForeSight feature is a dynamic closed-loop, rate-based, congestion management feature that yields bandwidth savings compared to non-ForeSight equipped trunks when transmitting bursty data across cell-based networks.

ForeSight permits users to burst above their committed information rate for extended periods of time when there is unused network bandwidth available. This enables users to maximize the use of network bandwidth while offering superior congestion avoidance by actively monitoring the state of shared trunks carrying frame relay traffic within the network.

ForeSight monitors each path in the forward direction to detect any point where congestion may occur and returns the information back to the entry to the network. When spare capacity exists with the network, ForeSight permits the extra bandwidth to be allocated to active virtual circuits. Each PVC is treated fairly by allocating the extra bandwidth based on each PVC's committed bandwidth parameter.

Conversely, if the network reaches full utilization, ForeSight detects this and quickly acts to reduce the extra bandwidth allocated to the active PVCs. ForeSight reacts quickly to network loading in order to prevent dropped packets. Periodically, each node automatically measures the delay experienced along a frame relay PVC. This delay factor is used in calculating the ForeSight algorithm.

With basic frame relay service, only a single rate parameter can be specified for each PVC. With ForeSight, the virtual circuit rate can be specified based on a minimum, maximum, and initial transmission rate for more flexibility in defining the frame relay circuits.

ForeSight provides effective congestion management for PVC's traversing broadband ATM as well. ForeSight operates at the cell-relay level that lies below the frame relay services provided by the IPX. With the queue sizes utilized in the BPX, the bandwidth savings is approximately the same as experienced with lower speed trunks. When the cost of these lines is considered, the savings offered by ForeSight can be significant.

Network Management

BPX Service Node nodes provide one high-speed and two low-speed data interfaces for data collection and network management. The high-speed interface is an Ethernet 802.3 LAN interface port for communicating with a StrataView Plus NMS workstation. TCP/IP provides the transport and network layer, Logical Link Control 1 is the protocol across the Ethernet port.

The low-speed interfaces are two RS-232 ports, one for a network printer and the second for either a modem connection or a connection to an external control terminal. These low-speed interfaces are the same as provided by the IPX nodes.

A StrataView Plus NMS workstation connects to the Ethernet (LAN) port on the BPX and provides network management via SNMP. Statistics are collected by SV+ using the TFTP protocol. On IPX shelves, frame relay connections are managed via the SV+ Connection Manager. On AXIS shelves, the SV+ Connection Manager manages frame relay and ATM connections, and the Connection Manager is used for AXIS shelf configuration

Each BPX Service Node can be configured to use optional low-speed modems for inward access by StrataCom International Support Center for network troubleshooting assistance or to autodial Cisco StrataCom Customer Service or a customer representative to report alarms remotely. If desired, another option is remote monitoring or control of customer premise equipment through a window on the StrataView Plus workstation.

Network Interfaces

Network interfaces connect the BPX node to other BPX, IGX, or IPX nodes to form a wide-area network.

The BPX provides T3, E3, OC3/STM-1, and OC12/STM-4 trunk interfaces. The T3 physical interface utilizes DS3 C-bit parity and the 53-byte ATM physical layer cell relay transmission using the Physical Layer Convergence Protocol. The E3 physical interface uses G.804 for cell delineation and HDB3 line coding. The BNI-155 card supports single-mode fiber (SMF), single-mode fiber long reach (SMF-LR), and multi-mode fiber (MMF) physical interfaces. The BXM-155 cards support SMF, SMFLR, and MMF physical interfaces. The BXM-622 cards support SMF and SMFLR physical interfaces.

The design of the BPX permits it to support network interfaces up to 622 Mbps in the current release while providing the architecture to support higher broadband network interfaces as the need arises.

Optional redundancy is on a one-to-one basis. The physical interface can operate either in a normal or looped clock mode. And as an option, the node synchronization can be obtained from the DS3 extracted clock for any selected network trunk.

Service Interfaces

Service interfaces connect ATM customer equipment to the BPX. ATM User-to-Network Interfaces (UNI) and ATM Network-to-Network Interfaces (NNI) terminate on the ATM Service Interface (ASI) cards and on BXM OC-3 and OC-12 cards configured for as service interfaces (UNI access mode). The ASI-1 card provides two T3 or E3 ports. The ASI-155 card OC3/STM-1 trunk interfaces are single-mode fiber (SMF), single-mode fiber long reach (SMF-LR), and multi-mode fiber (MMF) physical interfaces. The BXM-155 cards support SMF, SMFLR, and MMF physical interfaces. The BXM-622 cards support SMF and SMFLR physical interfaces. The ASI and BXM cards support cell relay connections that are compliant with both the physical layer and ATM layer standards.

The StrataCom ATM Interface Shelf (AXIS) interfaces to the Broadband Network Interface (BNI) card, via a T3 or E3 ATM STI interface, respectively, or via an OC3 interface. The AXIS provides a concentrator for T1 or E1 frame relay and ATM connections to the BPX Service Node with the ability to apply ForeSight across a connection from end-to-end. The AXIS also supports FUNI (Frame Based UNI over ATM) connections.

Statistical Alarms and Network Statistics

The BPX Service Node system manager can configure alarm thresholds for all statistical type error conditions. Thresholds are configurable for conditions such as frame errors, out of frame, bipolar errors, dropped cells, and cell header errors. When an alarm threshold is exceeded, the NMS screen displays an alarm message.

Graphical displays of collected statistics information, a feature of the StrataView Plus NMS, are a useful tool for monitoring network usage. Statistics collected on network operation fall into two general categories:

- Node statistics
- Network trunk statistics
- Network Service, line statistics
- Network Service, port statistics

These statistics are collected in real-time throughout the network and forwarded to the StrataView Plus workstation for logging and display. The link from the node to StrataView Plus uses a protocol to acknowledge receipt of each statistics data packet. Refer to the *StrataView Plus Operations Manual*, for more details on statistics and statistical alarms.

Node Synchronization

A BPX Service Node network provides network-wide, intelligent clock synchronization. It uses a fault-tolerant network synchronization architecture recommended for Integrated Services Digital Network (ISDN). The BPX Service Node internal clock operates as a Stratum 3 clock per ANSI T1.101.

Since the BPX Service Node is designed to be part of a larger communications network, it is capable of synchronizing to higher-level network clocks as well as providing synchronization to lower-level devices. Any network access input can be configured to synchronize the node. Any external T1 or E1 input can also be configured to synchronize network timing. A clock output allows synchronizing an adjacent IPX or other network device to the BPX Service Node and the network. In nodes equipped with optional redundancy, the standby hardware is locked to the active hardware to minimize system disruption during system switchovers.

The BPX Service Node does not accept clock from an IPX. The BPX Service Node can be configured to select clock from the following sources:

- External (T1/E1)
- Line (DS3/E3)
- Internal

Node Availability

Hardware and software components are designed to provide a node availability in excess of 99.99%. Network availability will be much more impacted by link failure, which has a higher probability of occurrence, than equipment failure.

Because of this, StrataCom switches are designed so that connections are automatically rerouted around network trunk failures often before users detect a problem. System faults are detected and corrective action taken often before they become service affecting. The following paragraphs describe some of the features that contribute to network availability.

Node Redundancy

System availability is a primary requirement with the BPX Service Node . The designed availability factor of a BPX Service Node is (99.99%) based on a node equipped with optional redundancy and a network designed with alternate routing available. The system software, as well as firmware for each individual system module, incorporates various diagnostic and self-test routines to monitor the node for proper operation and availability of backup hardware.

For protection against hardware failure, a BPX shelf can be equipped with the following redundancy options:

- Redundant common control modules
- Redundant crosspoint switch matrixes
- Redundant high-speed data and control lines
- Redundant power supplies
- Redundant high-speed network interface cards
- Redundant service interface cards

If redundancy is provided for a BPX shelf, when a hardware failure occurs, a hot-standby module is automatically switched into service, replacing the failed module. All cards are hot-pluggable, so replacing a failed card in a redundant system can be performed without disrupting service.

Since the power supplies share the power load, redundant supplies are not idle. All power supplies are active; if one fails, then the others pick up its load. The power supply subsystem is sized so that if any one supply fails, the node will continue to be supplied with adequate power to maintain normal operation of the node. The node monitors each power supply voltage output and measures cabinet temperature to be displayed on the NMS terminal or other system terminal.

Node Alarms

Each BPX shelf within the network runs continuous background diagnostics to verify the proper operation of all active and standby cards, backplane control, data, and clock lines, cabinet temperature, and power supplies. These background tests are transparent to normal network operation.

Each card in the node has front-panel LEDs to indicate active, failed, or standby status. Each power supply has green LEDs to indicate proper voltage input and output. An Alarm, Status, and Monitor card collects all the node hardware status conditions and reports it using front panel LED indicators and alarm closures. Indicators are provided for major alarm, minor alarm, ACO, power supply status, and alarm history. Alarm relay contact closures for major and minor alarms are available from each node through a 15-pin D-type connector for forwarding to a site alarm system.

BPX shelves are completely compatible with the network status and alarm display provided by the optional StrataView Plus NMS workstation. In addition to providing network management capabilities, it displays major and minor alarm status on its topology screen for all nodes in a network. The StrataView Plus also provides a maintenance log capability with configurable filtering of the maintenance log output by node name, start time, end time, alarm type, and user specified search string.

BXM T3/E3, 155, and 622

This chapter describes the BXM card sets which include the BXM T3/E3, BXM-155, and BXM-622. card sets. The BXM cards may be configured for either trunk or service (port UNI) mode. In trunk mode they provide BPX network interfaces, and in service (port UNI) mode they provide service access to CPE.

The chapter includes the following:

- BXM Cards
- BXM Capabilities
- Card Operation
- BXM Functional Description
- Fault Management and Statistics
- Technical Specifications
- General SONET Notes
- User Commands
- Configuring Connections
- Command Line Interface Examples
- Configuring the BPX for SVCs
- Configuring the AXIS
- Resource Partitioning

BXM Cards

A BXM card set, using Application Specific Integrated Circuit (ASIC) technology, provides high speed ATM connectivity, flexibility, and scalability. The card set is comprised of a front card that provides the processing, management, and switching of ATM traffic and of a back card that provides the physical interface for the card set. An example of a BPX network provisioned with BXM-622 cards is shown in Figure 2-1.

The BXM card group includes the BXM-T3/E3, BXM-155, and BXM-622. These cards may be configured to support either trunk (network) or port (service access) interfaces. The BXM T3/E3 is available in 8 or 12 port versions with T3/E3 interfaces. The BXM-155 is available in 4 or 8 port versions with OC3/STM-1 interfaces. The BXM-622 is available in 1 or 2 port versions with

OC-12/STM-4 interfaces. The BXM card sets are compliant with ATM UNI 3.1 and Traffic Management 4.0 including ABR VS/VD and provide the capacity to meet the needs of emerging bandwidth driven applications.

For additional information on ATM Connections, refer to *Chapter 3, ATM Connections*, of this document or to the *System Overview* document.

Figure 2-1 A BPX Network with BXM Cards

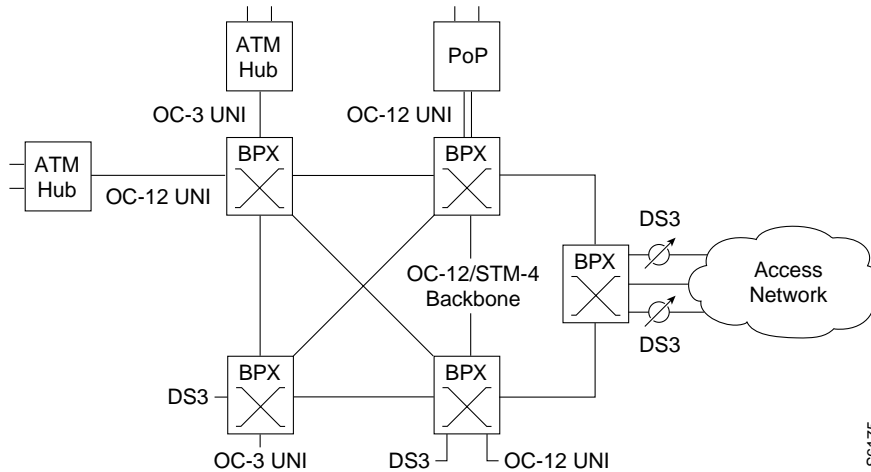

The BXM cards are designed to support all the following service classes: Constant Bit Rate (CBR), Variable Bit Rate (VBR), Available Bit Rate (ABR with VS/VD, ABR without VS/VD, and ABR using Foresight), and Unspecified Bit Rate (UBR). ABR with VS/VD supports explicit rate marking and Congestion Indication (CI) control.

All software and administration firmware for the BXM card is downloadable from the BCC and is operated by the BXM on-board sub-system processor.

A BXM card set consists of a front and back card. The BXM T3/E3 is available with a universal BPX-T3/E3 backcard in 8 or 12 port versions. The BXM-OC3 is available with 4 or 8 port multi-mode fiber (MMF), single mode fiber (SMF), or single mode fiber long reach (SMFLR) back cards. The BXM-OC12 is available with 1 or 2 port SMF or SMFLR back cards,

Any of the 12 general purpose slots can be used for the BXM cards. The same backcards are used whether the BXM ports are configured as trunks or lines. Table 2-1 and Table 2-2 list the available front and back card options for the BXM-T3/E3, BXM-155, and BXM-622.

Table 2-1 BXM-155 and BXM 622 Front Card Options

Front Card Model Number	No. of Ports	Cell Buffer (ingress/egress)	Connections per card	Back Cards
T3/E3 (45 Mbps/34Mbps)				
BXM-T3-8	8	100k/100k	16k/32k	BPX-T3/E3-BC
BXM-E3-8	8	100k/100k	16k/32k	BPX-T3/E3-BC
BXM-T3-12	12	100k/230k	16k/32k	BPX-T3/E3-BC
BXM-E3-12	12	100k/230k	16k/32k	BPX-T3/E3-BC
OC3/STM-1 (155.52 Mbps)				
BXM-155-8	8	230k/230k	16k	MMF-155-8 SMF-155-8 SMFLR-155-8
BXM-155-4	4	100k/230k	16K	MMF-155-4 SMF-155-4 SMFLR-155-4
OC12/STM-4 (622.08 Mbps)				
BXM-622-2	2	230k/230k	16K	SMF-622-2 SMFLR-622-2 SMFXLR-622-2
BXM-622	1	130k/230k	16K/32K	SMF-622 SMFLR-622 SMFXLR-622

*The BXM cards can be configured for either, but not both, trunk or service access (UNI) on a card by card basis. Once a card is so configured, all ports are either trunk or service interfaces until the card is reconfigured.

**The BPX-T3/E3-BC universal backcard supports 8 or 12 ports.

Table 2-2 BXM-155 and BXM-622 Back Cards

Back Card Model Number	No. of Ports	Description	Optical Range (less than or equal to)
T3/E3 (45 Mbps/34Mbps)			
BPX-T3/E3-BC	8/12	Universal T3/E3 backcard for 8 or 12 port card configurations	n/a
OC3/STM-1 (155.520 Mbps)			
MMF-155-8	8	Multi-Mode Fiber	2km
MMF-155-4	4	Multi-Mode Fiber	2km
SMF-155-8	8	Single-Mode Fiber	20km
SMF-155-4	4	Single-Mode Fiber	20km
SMFLR-155-8	8	Single-Mode Fiber Long Reach	40km
SMFLR-155-4	4	Single-Mode Fiber Long Reach	40km
OC12/STM-4 (622.08 Mbps)			
SMF-622-2	2	Single-Mode Fiber	20km
SMF-622	1	Single-Mode Fiber	20km
SMFLR-622-2	2	Single-Mode Fiber Long Range	40km
SMFLR-622	1	Single-Mode Fiber Long Range	40km

BXM Capabilities

The following lists some of the major capabilities of the BXM cards:

Features

- Virtual Path (VP) as well as Virtual Circuit (VC) connections.
- Support both PVC and SVC connections
- Connections supported per card:
 - 16,000 to 32,000 connections per card depending on configuration.
- BXM, T3/E3 ATM with 8 or 12 ports, either T3 at a 44.736 Mbps rate, or E3 at a 34.368 rate.
- BXM, OC-3/STM-1 ATM: four or eight ports, with each port operating at a 155.52 Mbps rate, 353,208 cells per second (full OC-3 rate)
- BXM, OC-12/STM-4 ATM: one or two ports, with each port operating at a 622.08 Mbps rate, 1,412,830 cells per second (full OC-12 rate).
- Selective Cell Discard.
- Up to 228,300 cell ingress (receive) buffers depending on card configuration
- Up to 228,300 cell egress (transmit) buffers depending on card configuration

- CBR, VBR, ABR, and UBR service classes
- ATM cell structure and format per ATM Forum UNI v3.1
- Loopback support
- 1:1 card redundancy using Y-cable configuration.
- A BXM card may be configured for either network or port (access) operation.

ATM Layer

- UNI port option conforming to ATM Forum UNI v3.1 specification
- ATM cell structure and format supported per ATM UNI v3.1 and ITU I.361
- Header Error Correction (HEC) field calculation and processing supported per ITU I.432
- Usage Parameter Control using single and dual leaky bucket algorithm, as applicable, to control admission to the network per ATM Forum 4.0 Traffic Management.
- Provides up to 16 CoS's with the following configurable parameters:
 - Minimum service rate
 - Maximum queue depth
 - Frame discard enable
 - Cell Loss Priority (CLP) High and Low thresholds
 - Service priority level
 - Explicit Forward Congestion Indication (EFCI) threshold
- Per VC Queuing
- Support for UBR CoS with Early Packet Discard
- Failure alarm monitoring per T1.64b
- ATM layer OAM functionality
- Congestion control mechanisms:
 - ABR with Virtual Source Virtual Destination (VSVD)
 - ABR with Explicit Rate (ER) stamping/EFCI tagging
 - ABR with ForeSight
- Self-test and diagnostic facility

Service Types

The BXM cards support the full range of ATM service types per ATM Forum TM 4.0.

CBR Service:

- Usage Parameter Control (UPC) and Admission Control
- UPC: Ingress rate monitoring and discarding per I.371 for:
 - Peak Cell Rate (PCR)
 - Cell Transfer Delay Variation (CTDV)

VBR Service:

- Usage Parameter Control (UPC) and Admission Control
- UPC: Ingress rate monitoring and cell tagging per ITU-T I.371 for:
 - Sustained Cell Rate (SCR)
 - Peak Cell Rate (PCR)
 - Burst Tolerance (BT)
- CLP tagging, enabled or disabled on a per VC basis at the Ingress side.

ABR Service:

- Based on Virtual Source Virtual Destination (VSVD) per ATM Forum TM4.0
- VSVD
 - VSVDs provide Resource Management (RM) cell generation and termination to support congestion control loops.
 - A virtual connection queue (VCQ) is assigned to a VC in the ingress direction.
 - VCQ configurable parameters:
 - CLP Hi and Lo thresholds
 - Maximum queue depth
 - Reserved queue depth
 - Congestion threshold
- ABR congestion control
 - Based on Explicit rate stamping/EFCI cell tagging and ingress rate monitoring per ITU-T I.371
 - ABR with Virtual Source Virtual Destination (VSVD)
 - ABR with Explicit Rate (ER) stamping/EFCI tagging
 - ABR with ForeSight

UBR Service:

- based on UPC and admission control including EPD.
- based on Explicit Rate Marking/EFCI cell tagging and ingress rate monitoring per ITU-T I.371

Virtual Interfaces

- VPI/VCI used to identify virtual connection
- Support for up to 32 virtual interfaces per card, each with 16 CoS queues.
- Virtual Interface parameters:
 - Physical port (trunk or access)
 - Peak Service Rate (PSR)
 - Minimum Service Rate (MSR)
 - Maximum resource allocation

Card Operation

BXM Front Card Indicators

The BXM front panel has a three-section, multi-colored “card” LED to indicate the card status. A two-port BXM-622, an 8-port BXM-155 front card, and a 12-port BXM-T3/E3 are shown in figures Figure 2-2, Figure 2-3, and Figure 2-4, respectively. The card status LED is color-coded as indicated in Table 2-3. A three-section multi-colored “port” LED indicates the status of the ports. Types of failures are indicated by various combinations of the card status indicators as indicated in Table 2-4.

Table 2-3 BXM Front Panel Status Indicators

Status	LED color	Status Description
port	off	Trunk/line is inactive and not carrying data.
	green	Trunk/line is actively carrying data.
	yellow	Trunk/line is in remote alarm.
	red	Trunk/line is in local alarm.
card	green (act)	Card is on-line and one or more trunks/lines on the card have been upped. If off, card may be operational but is not carrying traffic.
	yellow (stby)	Card is off-line and in standby mode (for redundant card pairs). May not have any upped trunks/lines. If blinking, indicates card firmware or configuration data is being updated.
	red (fail)	Card failure; card has failed self-test and/or is in a reset mode. See Table 2-4 for more information.

Table 2-4 BXM Front Panel Card Failure Indications

act	stby	fail	Failure Description
on	off	on	Non-fatal error detected; card is still active.
off	on	on	Non-fatal error detected; card is in standby mode.
off	blinking	on	Fatal error detected; card is in a reboot mode.
on	on	on	Card failed boot load and operation is halted.

Figure 2-2 BXM-622 Front Panel, Two-Port Card Shown

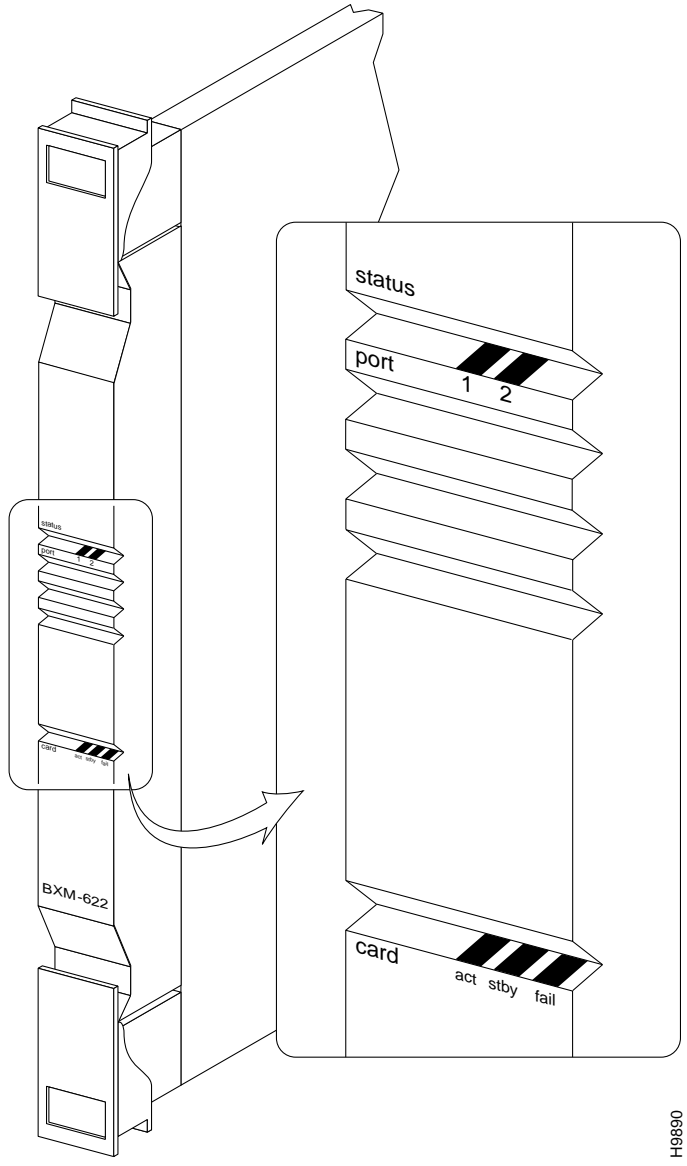

0686H

Figure 2-3 BXM-155 Front Panel, Eight-Port Card Shown

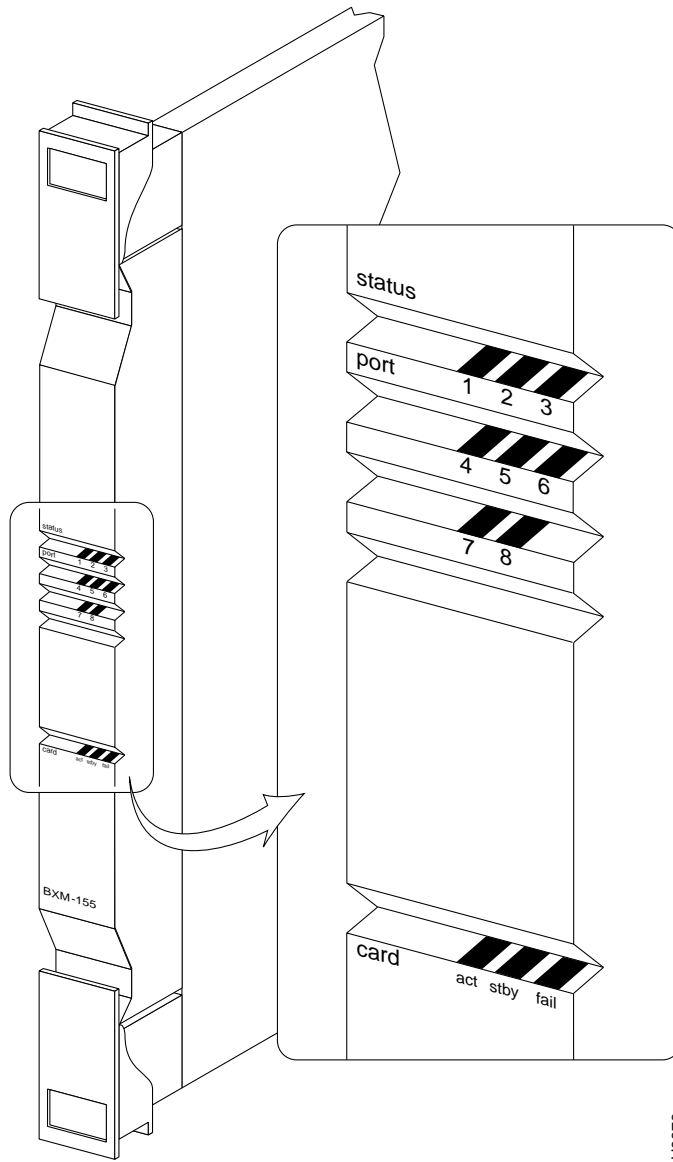
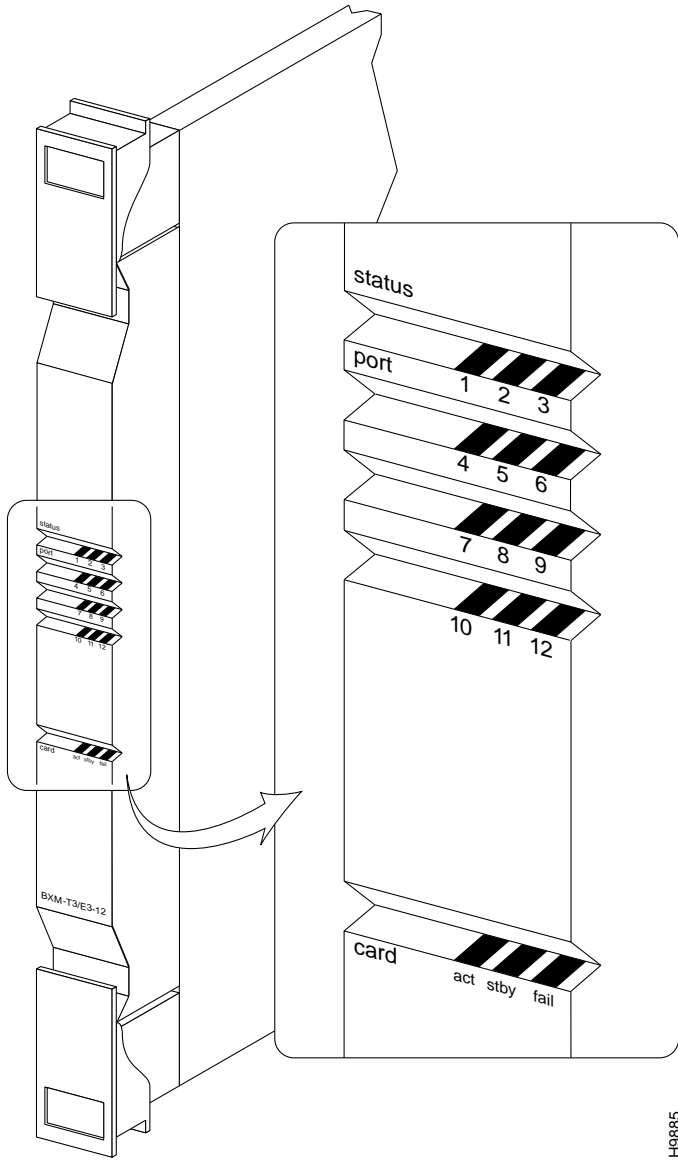

Figure 2-4 BXM-T3/E3 Front Panel, 12-Port Card Shown



H9885

BXM, Backcard Connectors

The BXM backcards connect to the BXM front cards through the StrataBus midplane.

The BXM-622 is available in one or two port versions in either a single-mode fiber intermediate range (SMF) or a single-mode fiber long range (SMFLR) backcard. Connector information is listed in Table 2-5 and a 2-port SMF card is shown in Figure 2-5.

Table 2-5 BXM-622 Backcards

No.	Connector	Function
1 or 2	PORT	Two FC connectors per port, one each for the transmit and receive signal

The BXM-155 is available in four or eight port versions in a choice of multi-mode fiber (MMF), single-mode fiber intermediate range (SMF), or single-mode fiber long range (SMFLR) backcards. Connector information is listed in Table 2-6 and an 8-port SMF card is shown in Figure 2-6.

Table 2-6 BXM-155 Backcards

No.	Connector	Function
4 or 8	PORT	One SC connector per port, accommodates both the transmit and receive signals.

The BXM-T3/E3 is available in 8 or twelve port versions. Connector information is listed in Table 2-7 and a 12-port T3/E3 card is shown in Figure 2-7.

Table 2-7 BXM-T3/E3 Backcards

No.	Connector	Function
8 or 12	PORT	Two SMB connectors per port, one each for the transmit and receive signals.

Figure 2-5 SMF-622-2, SMFLR-622-2, and SMFXLR-622-2 Back Card

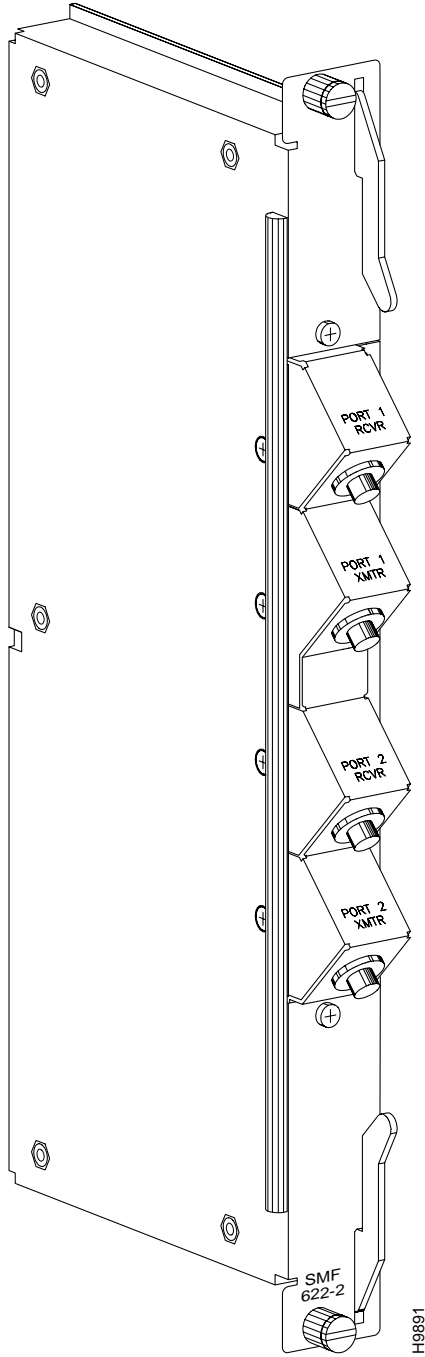
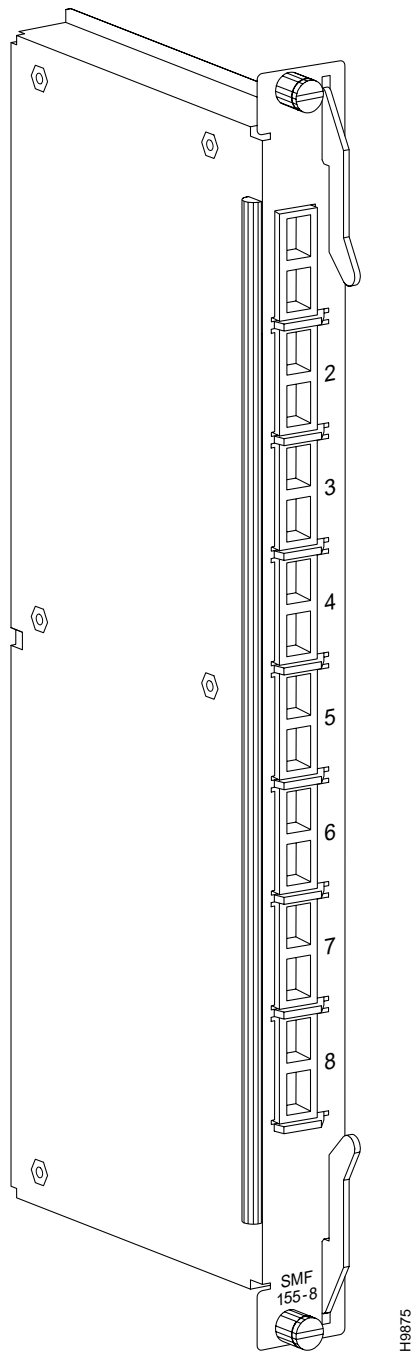

Figure 2-6 BXM-155-8 Port Backcard, MMF, SMF, or SMFLR



Y-Cabling of SMF-622 Series Backcards

The SMF-622 series backcards may be Y-cabled for redundancy using the Y-Cable splitter shown in Figure 2-8. The cards must be configured for Y-Cable redundancy using the **addyred** command.

Figure 2-8 Y-Cabling of SMF-622 Series Backcards

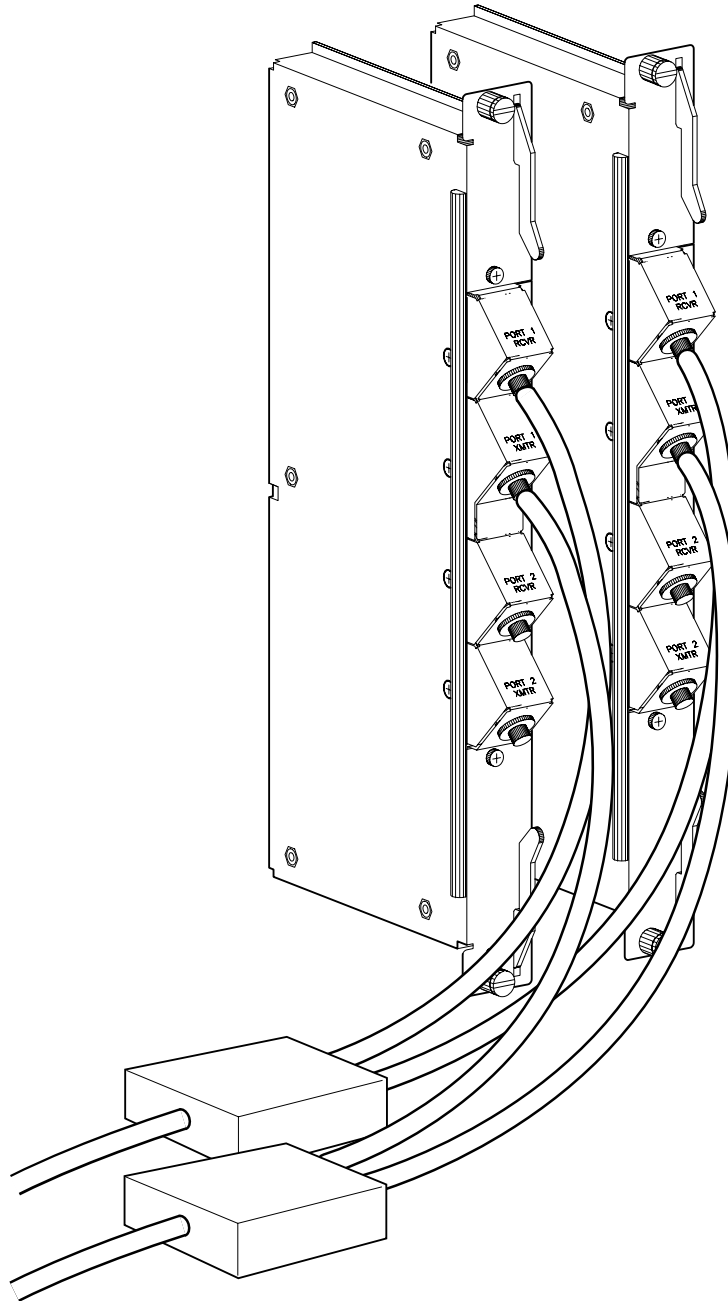

-BPX0701.EPS

BXM Functional Description

This functional description provides an overview of BXM operation.

Overview, Port (UNI) Mode

The following provides an overview of the operation of the BXM card when the ports are configured in port (access) mode for connection to customer equipment (CPE).

Ingress

The ingress flow of ATM cells into the BXM when the card is configured for port (access) operation is shown in Figure 2-9.

ATM cells from the CPE are processed at the physical interface level by the SUNI (OC3/OC12) or Mux/Demux (T3/E3), policed per individual VC by the RCMP and routed to applicable ingress queues. In addition, for ABR cells, additional functions are performed by the SABRE ABR connection controller, including: VS/VD, Foresight, and virtual connection queueing. The cells are served out via the BPX Backplane to the BPX crosspoint switch in an order of priority based on their connection type.

Figure 2-9 **BXM Port (Access UNI) Ingress Operation**

Egress

The egress flow of ATM cells out of the BXM when the card is configured for port (access) operation is shown in Figure 2-10.

ATM cells are routed to the BXM-622 via the BPX Backplane/Stratabus from the BPX crosspoint switch, applied to the DRSIU, then to an egress queue per class of service, and then served out to the SUNI (OC3/OC12) or Mux/Demux (T3/E3) which processes the ATM cells into frames, processing the cells from the ATM layer to the physical and on out to the CPE connected to the port(s) on the BXM backcard. In addition, for ABR cells, additional functions are performed by the SABRE ABR connection controller, including: VS/VD, Foresight, and virtual connection queueing.

Figure 2-10 BXM Port (Access, UNI) Egress Operation

SABRE	Scheduling and ABR Engine	SUNI	SONET/SDH UNI ASIC
SIMBA	Serial I/F and Multicast Buffer ASIC	ACP	Sub-system Processor
RCMP	Routing Ctl, Monitoring, & Policing ASIC	ASIC	Application Specific Integrated Ckt
DRSIU	Dual Receiver Serial I/F Unit		

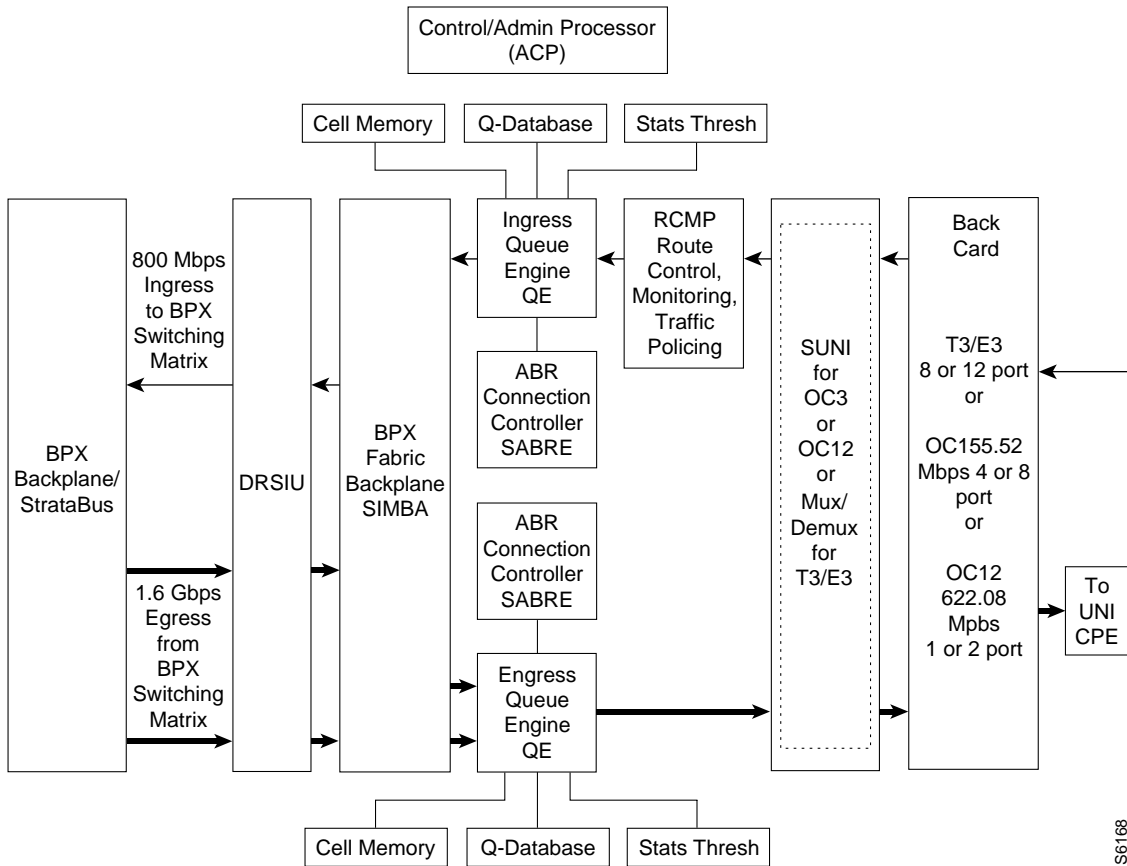

S6168

Overview, Trunk Mode

This following provides an overview of the operation of the BXM when the card is configured in the trunk mode for connection to another node or network.

Ingress

The ingress flow of ATM cells into the BXM when the card is configured for trunk operation is shown in Figure 2-11.

ATM cells from a node or network are processed at the physical interface level by the SUNI (OC3/OC12) or Demux/Mux (T3/E3), routed to applicable ingress slot queues, and served out to the BPX crosspoint switch via the BPX Backplane.

Figure 2-11 BXM Trunk Ingress Operation

SABRE	Scheduling and ABR Engine	SUNI	SONET/SDH UNI ASIC
SIMBA	Serial I/F and Multicast Buffer ASIC	ACP	Sub-system Processor
RCMP	Routing Ctl, Monitoring, & Policing ASIC	ASIC	Application Specific Integrated Ckt
DRSIU	Dual Receiver Serial I/F Unit		

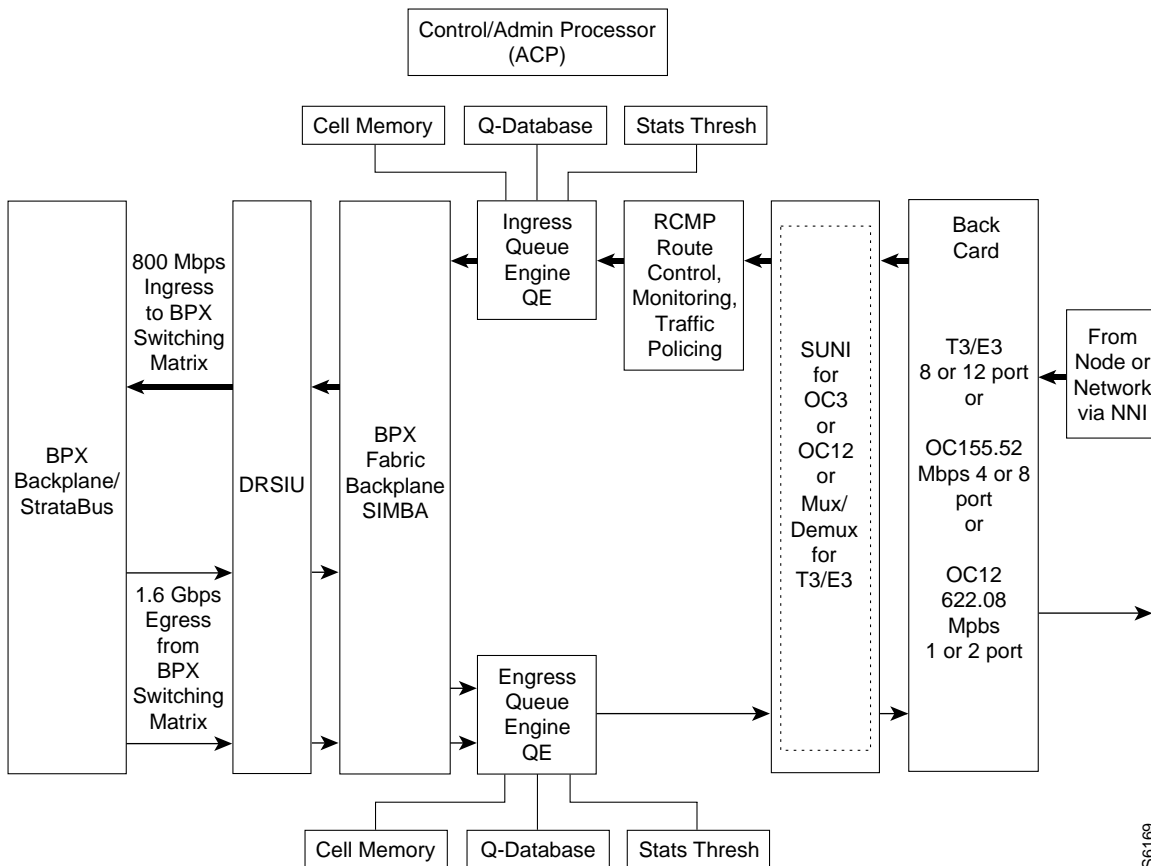

S6169

Egress

The egress flow of ATM cells out of the BXM when the card is configured for trunk operation is shown in Figure 2-12.

ATM cells are routed to the BXM from the BPX crosspoint switch, applied to the DRSIU, then to an egress queue per class of service, and then served out to the SUNI (OC3/OC12) or Demux/Mux (T3/E3). The SUNI or Demux/Mux, as applicable, processes the ATM cells into frames, processing the cells from the ATM layer to the physical and on out to the backcard trunk interface connecting to another node or network.

Figure 2-12 BXM Trunk Egress Operation

SABRE	Scheduling and ABR Engine	SUNI	SONET/SDH UNI ASIC
SIMBA	Serial I/F and Multicast Buffer ASIC	ACP	Sub-system Processor
RCMP	Routing Ctl, Monitoring, & Policing ASIC	ASIC	Application Specific Integrated Ckt
DRSIU	Dual Receiver Serial I/F Unit		

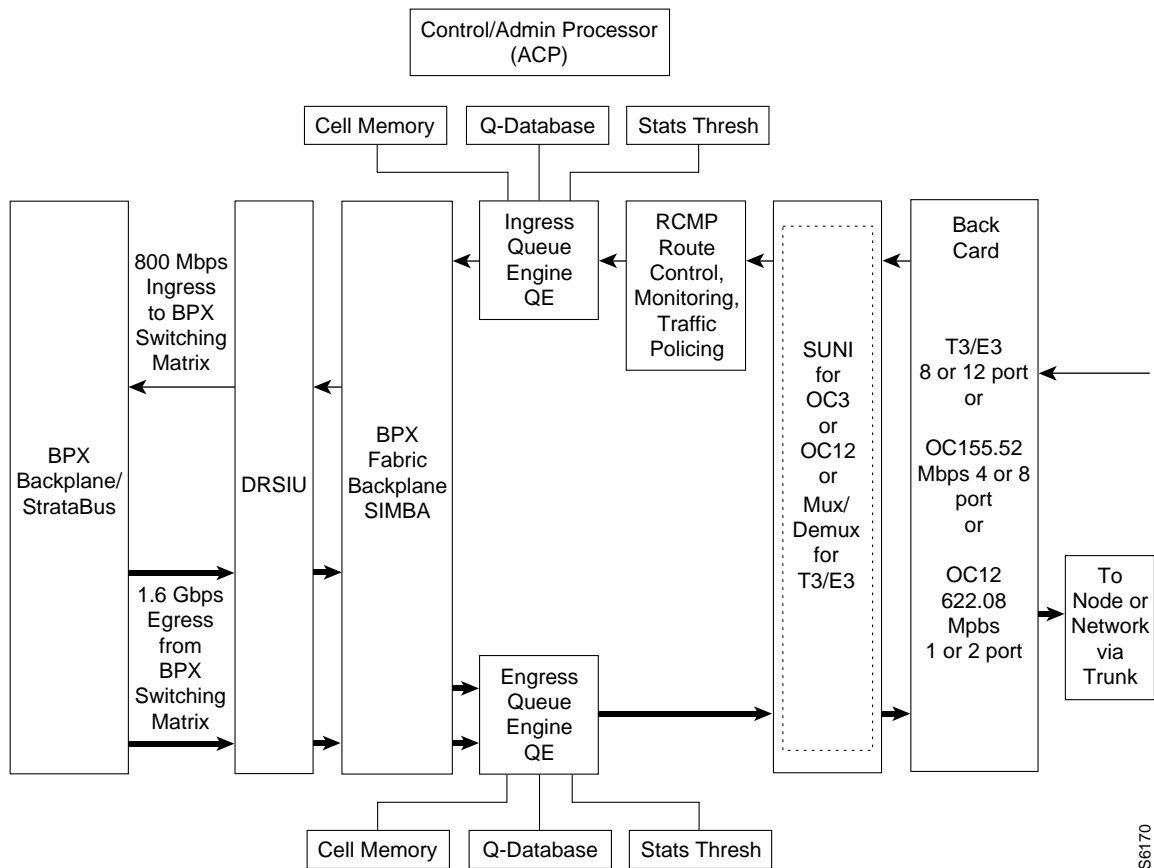

S6170

Detailed Description, Port (UNI) and Trunk Modes

The following provides a summary of the principal functions performed by the major functional circuits of the BXM.

DRSIU

The DRSIU provides a total egress capacity from the BPX switch fabric of 1.6 Gbps.

SONET/SDH UNI (SUNI)

The SUNI ASIC implements the BXM physical processing for OC3 and OC12 interfaces. The SUNI provides SONET/SDH header processing, framing, ATM layer mapping and processing functions for OC12/STM-4 (622.08 Mbps) or OC3/STM1 (155.52 Mbps)

For ingress traffic, the BXM physical interface receives incoming SONET/SDH frames, extracts ATM cell payloads, and processes section, line, and path overhead. For egress traffic ATM cells are processed into SONET/SDH frames.

Alarms and statistics are collected at each level: section, line and path.

DeMux/Mux

The Demux/Mux and associated circuits implement the BXM physical layer processing for T3/E3 interfaces, providing header processing, framing, ATM layer mapping, and processing functions for T3 at a 44.736 Mbps rate, or E3 at a 34.368 rate.

RCMP

Usage Parameter Control (UPC) is provided by the RCMP. Each arriving ATM cell header is processed and identified on a per VC basis. The policing function utilizes a leaky bucket algorithm.

In addition to UPC and traffic policing, the RCMP provides route monitoring and also terminates OAM flows to provide performance monitoring on an end-to-end per VC/VP basis.

Traffic policing and UPC functionality is in accordance with the GCRA as specified by ATM Forum's UNI 3.1 using dual leaky buckets.

- Leaky Bucket 1 utilizes:
 - Peak Cell Rate (PCR)
 - Cell Delay Variation Tolerance: CDVT
- Leaky Bucket 2 utilizes:
 - Sustainable Cell Rate (SCR)
 - Maximum Burst Size (MBS)

In addition, two selective cell discard thresholds are supported for all queues for discard of CLP=1 cells should congestion occur.

SABRE

The Scheduling and ABR Engine (SABRE) includes both VS/VD and Foresight dynamic traffic transfer rate control and other functions:

- ATM Forum Traffic Management 4.0 compliant ABR Virtual Source/Virtual Destination (VS/VD)
- Terminates ABR flows for VS/VD and Foresight control loops
- Performs explicit rate (ER) and EFCI tagging if enabled
- Supports Foresight congestion control and manages the designated service classes on a per VC basis with OAM processing.
- Supports OAM flows for internal loopback diagnostic self-tests and performance monitoring.
- Provides service queue decisions to the Ingress and Egress Queue Engines for per VC queues for ABR VCs.

Ingress and Egress Queue Engines

The overall function of the queue engines is to manage the bandwidth of trunks or ports (UNI) via management of the ingress and egress queues.

In addition to the ABR VS queues, the ingress queues include 15 slot servers, one for each of 14 possible BPX destination slots, plus 1 for multicast operation. Each of the 15 slot servers contains 16 Qbins, supporting 16 classes of service per slot server.

In addition to the ABR VS queues, the egress queues include 32 Virtual Interfaces (VIs). Each of the 32 VIs supports 16 Qbins.

SIMBA

This serial interface and multicast buffer ASIC provides the following:

- ATM cell header translation
- Directs ATM cells to the Egress Queue Engine with a 2 x OC-12c throughput capacity
- Implements the multi-cast function in the egress direction, providing up to 4000 multicast connections.
- Translates standard OAM flows and Foresight cells.
- Optimizes backplane bandwidth by means of a polling mechanism.

ACP Subsystem Processor

The ACP performs the following localized functions:

- Initializes BXM at power up
- Manages local connection databases
- Collects card, port, and connection statistics
- Manages OAM operation
- Controls alarm indicators (active, standby, fail)

All basic configuration data on the card is copied to the battery backup memory (BRAM) on the card so that in the event of a power outage, the card will retain its main configuration.

Fault Management and Statistics

Note This is a preliminary listing.

Fault Management and Statistics, Port (UNI) Mode

Compliant to Bellcore GR-253-CORE

Alarms:

- Loss Of Signal (LOS)
- Loss Of Pointer (LOP)
- Loss Of Frame (LOF)
- Loss Of Cell delineation (LOC)
- Alarm Indication Signal (AIS)
- Remote Defect Indication (RDI)
- Alarm Integration Up/down Count

Performance Monitoring:

- Performance monitoring provided for Line, Section, and Path
- Bit Interleaved Parity (BIP) error detection
- Far End Block Error (FEBE) count
- Unavailable Seconds (UAS)
- Errored Seconds (ES)
- Severely Errored Seconds (SES)
- Header Error Checksum (HCS) monitoring

Statistics:

- ATM statistics collected on a per VC basis
 - Two modes of statistics collection:
 - Basic: collection of 4 statistics per VC per direction
 - Enhanced: collection of 12 statistics per VC per direction

OAM

- Loopback support
- Generation and detection of AIS and RDI OAM cells
- Termination and processing of OAM cells

Fault Management and Statistics, Trunk Mode

Compliant to Bellcore GR-253-CORE

Alarms:

- Loss Of Signal (LOS)
- Loss Of Pointer (LOP)
- Loss Of Frame (LOF)
- Loss Of Cell delineation (LOC)
- Alarm Indication Signal (AIS)
- Remote Defect Indication (RDI)
- Alarm Integration Up/down Count

Performance Monitoring:

- Performance monitoring provided for Line, Section and Path
- Bit Interleaved Parity (BIP) error detection
- Far End Block Error (FEBE) count
- Unavailable Seconds (UAS)
- Errored Seconds (ES)
- Severely Errored Seconds (SES)
- Header Error Checksum (HCS) monitoring

Statistics:

Process Monitoring for ATM Header Cell Processing

- Cells discarded due to Header Errors (LCN mismatch)

Miscellaneous ATM Layer Statistics

- Number of cell arrivals from port
- Number of cell arrivals with CLP = 1
- Number of cells transmitted to port
- Number of cells transmitted with CLP = 1

Technical Specifications

Physical Layer

- Trunk or port (access) interface mode
- Compliant to SONET standards
 - *Bellcore GR-253-CORE, TR-TSY-000020
 - *ANSI T1.105, T1E1.2/93-020RA
- Compliant to SDH standards
 - *ITU-T G.707, G.708 and G.709
 - *ITU-T G.957, G.958
- 1:1 BXM redundancy supported using 'Y' redundancy
- Fiber optic interface characteristics for are listed in Table 2-8 and Table 2-9.

Table 2-8 Fiber Optic Interface Characteristics OC12

Back card	Source 1310 nm	Tx Power (dBm)		Rx Power (dBm)		Connection Type	Range (km)
		Min	Max	Min	Max		
SMF (IR)	Laser	-15	-8	-28	-8	FC	20
SMF (LR)	Laser	-3	+2	-28	-8	FC	40
SMF (XLR)	Laser						

Table 2-9 Fiber Optic Interface Characteristics OC3

Back card	Source	Tx Power (dBm)		Rx Power (dBm)		Connection Type	Range (km)
		Min	Max	Min	Max		
MMF	LED	-22	-15	-34	-10	SC	2
SMF (IR)	Laser 1310 nm	-15	-8	-34	-10	FC	20
SMF (LR)	Laser 1310 nm	-5	0	-34	-10	FC	40

General Information

- Card dimensions: 19”(H) x 1.1“(W) x 27”(D)
- Weight: 6 lb (2.7kg)
- Power -48 V DC at 85 W

- EMI/ESD: FCC Part 15, Bellcore GR1089-CORE
- IEC 801-2, EN55022
- Safety: EN 60950, UL 1950
- Bellcore NEBS:Level 3 compliant
- Optical Safety:
 - Intermediate Reach IEC 825-1 (Class 1)
 - Long Reach IEC 825-1 (Class 36)

General SONET Notes

SONET is defined across three elements, section, line, and path as shown in Figure 2-13 and described in Table 2-10. An advantage of this tiered approach is that management control can be exercised at each level, for example at the section level independent of the line or path level

Figure 2-13 SONET Section, Line, and Path

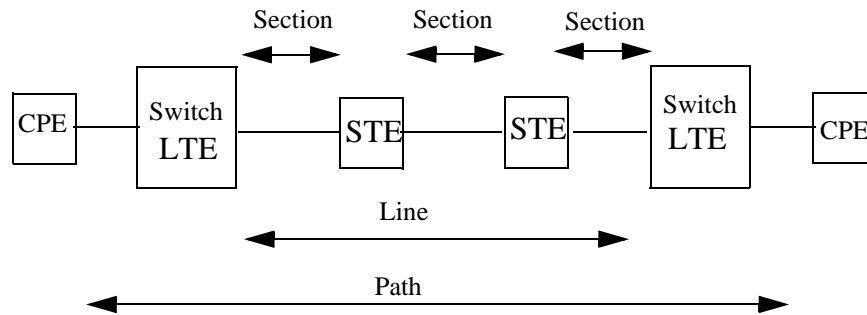

Table 2-10 SONET Section, Line, and Path Descriptions

Unit	Description
Section	A section is the fiber optic cable between two active elements such as simple repeaters. The active element terminating these sections is called Section Terminating Equipment (STE).
Line	A line is a physical element that contains multiple sections and repeaters and is terminated by line terminating equipment (LTE) at each end.
Path	A path includes sections and lines and terminates at the customer premises equipment (CPE)

Table 2-11 provides a cross-reference between OC-n optical carrier levels and the equivalent STS-n and SDH-n levels. It also includes the associated line rates.

Table 2-11 Digital Hierarchies

OC-n Optical Carrier	STS-n Synchronized Transport Signal	Line Rates (Mbps)	SDH-n Synchronized Digital Hierarchy	STM-n Synchronous Transport Module
OC-1	STS-1	51.84		
OC-3	STS-3	155.52	SDH-1	STM-1
OC-12	STS-12	622.08	SDH-4	STM-4
OC-48	STS-48	2488.32	SDH-16	STM-12

User Commands

This section provides a preliminary summary of configuration, provisioning, and monitoring commands associated with the BXM cards. These commands apply to initial card configuration, line and trunk configuration and provisioning, and connection configuration and provisioning.

New or modified commands include but are not limited to:

Connection Provisioning

- addcon- add connection
- cnfcon- configure connection
- dspcon- display connection

Diagnostics

- addlnloclp-add local loopback to line
- addlnlocrmtlp-add local remote loopback to line
- dellnlp-delete local or remote loopback

Test

- tstconseg-test connection externally with OAM segment loopback cells
- tstdelay-test connection round trip delay

Statistics

- Line and Trunk statistics
 - cnflnstats-configure line statistics collection
 - dsplnstatcnf-display statistics enabled for a line
 - dsplnstathist-display statistics data for a line

- cnfrkstats-configure trunk statistics collection
- dsptrkstatcnf-display statistics enabled for a trunk
- dsptrkstathist-display statistics data for a trunk
- Channel Statistics
 - cnfchstats- configure channel statistics collection
 - dspchstatcnf-display statistics configuration for a channel
 - dspchstathist-display statistics data for a channel
 - dspchstats-display channel statistics (multisession permitted)
- Line Statistics
 - cnfslotalm-configure slot alarm threshold
 - dspslotalms-display slot alarms
 - clrslotalm-clear slot alarm
 - dspsloterrs-display slot errors
- Statistical Trunk/Line Alarms
 - cnflnalm-configure line alarm threshold
 - dsplnerrs-display line errors
 - dsplnalmcnf- display line alarm configuration
 - clrlnalm-clear line alarm

Configuring Connections

Connections are typically provisioned and configured using StrataView Plus. However, the connections can also be added using the BPX command line interface (CLI). This may be appropriate during initial local node setup and when a Strata View Plus workstation is not available.

There are two connection addressing modes supported. The user may enter a unique VPI/VCI address in which case the BPX functions as a virtual circuit switch. Or the user may enter only a VPI address in which case all circuits are switched to the same destination port and the BPX functions as a virtual path switch in this case. The full ATM address range for VPI and VCI is supported.

Connections are routed between CPE connected to BXM ports. Before adding connections, the BXM is configured for port mode.

Note The initial command to up a trunk (**uptrk**) or to up a line (**upln**) on the BXM card configures all the ports of the card to be either trunks or lines (UNI port access), respectively. (Comment: This note may be subject to change.) Following the **uptrk** command at each port, the **addtrk** command is used to activate a trunk for network access.

A line is upped with the **upln** command and configured with the **cnfln** command. Then the associated port is configured with the **cnfport** command and upped with the **upport** command. Following this, the ATM connections are added via the **addcon** command.

The slot number is the BXM card slot on the BPX. The port number is one of two ports on the BXM, the VPI is the virtual path identifier, and the VCI is the virtual circuit identifier.

The VPI and VCI fields have significance only to the local BPX, and are translated by tables in the BPX to route the connection. Connections are automatically routed by the AutoRoute feature once the connection endpoints are specified.

Connections can be either Virtual Path Connections (VPC) or Virtual Circuit Connections (VCC). Virtual Path Connections are identified by an * in the VCI field. Virtual Circuit Connections specify both the VPI and VCI fields.

Refer to *Chapter 3* of this document and to the *System Overview* document for further information on ATM connections.

Configuration Management

The following parameters are entered for the BXM **addcon** command. Depending upon the connection type, the user is prompted with appropriate parameters as shown below.

Syntax:

addcon local_addr node remote_addr traffic_type ...extended parameters

Field	Value	Description
local/remote_addr	slot.port.vpi.vci	desired VCC or VPI connection identifier
node		slave end of connection
traffic_type		Type of traffic, chosen from CBR, VBR, ABR, and UBR.
extended parameters		parameters associated with each connection type

Note The range of VPIs and VCIs reserved for PVC traffic and SVC traffic is configurable using the **cnfport** command. While adding connections, the system checks the entered VPI/VPC against the range reserved for SVC traffic. If there is a conflict, the **addcon** command fails with the message “VPI/VCI on selected port is reserved at local/remote end”.

Command Line Interface Examples

The following pages have a number of command examples, including configuring BXM lines and trunks and adding connections terminating on BXM cards.

An example of the **uptrk** command for trunk 1 on a BXM in slot 4 of a BPX follows:

```
pubsbpx1      TN      StrataCom      BPX 15      8.5      Jan. 23 1997 18:52 GMT

TRK      Type      Current Line Alarm Status      Other End
1.1      T3      Clear - OK      pubsaxil (AXIS)
1.3      T3      Clear - OK      pubsipx1/8
4.1      OC3      Clear - OK      -
```

Last Command: uptrk 4.1

Next Command:

Note Note: The initial command to up a trunk (**uptrk**) or to up a line (**upln**) on the BXM card configures all the ports of the card to be either trunks or lines (UNI port access), respectively. (Comment: This note may be subject to change.) Following the **uptrk** command at each port, the **addrk** command is used to activate a trunk for network access.

An example of the **cnftrk** command for trunk 4.1 of a BXM card follows:

```
pubsbpx1      TN      StrataCom      BPX 15      8.5      Jan. 23 1997 18:50 GMT

TRK 4.1 Config OC3 [353207cps]      BXM slot:      4
Transmit Rate:      353208      Restrict CC traffic: No
Subrate interface:  --      Link type:      Terrestrial
Subrate data rate:  --      Line framing:   STS-3C
Line DS-0 map:      --      coding:         --
Pass sync:          Yes      CRC:            --
Loop clock:         No      recv impedance: --
Statistical Reserve: 1000 cps      cable type:     --
Idle code:          7F hex      length:         --
Max Channels/Port:  256      HCS Masking:    Yes
Connection Channels: 256      Payload Scramble: Yes
Valid Traffic Classes:
    V,TS,NTS,FR,FST,CBR,VBR,ABR      Frame Scramble:  Yes
SVC Channels:       --      Virtual Trunk Type: --
SVC Bandwidth:     -- cps      Virtual Trunk VPI: --
Deroute delay time: 0
```

This Command: cnftrk 4.1

Transmit Rate [T2=14490, E3=80000, T3=96000, OC3 = 353208, OC12=1412830](353208)

An example of the **addrk** command follows:

```
pubsbpx1      TN      StrataCom      BPX 15      8.5      Jan. 23 1997 18:54 GMT

TRK      Type  Current Line Alarm Status      Other End
1.1      T3    Clear - OK                      pubsaxil(Axis)
1.3      T3    Clear - OK                      pubsipx1/8
4.1      OC3   Clear - OK                      -
```

Last Command: dsptrks

Next Command: addrk 4.1

An example of the **upln** command for UNI port access on a BXM card follows:

```
pubsbsp1      TN      YourID:1      BPX 15      8.5      Jan. 23 1997 02:18 GMT

Line   Type   Current Line Alarm Status
3.1    OC3    Clear - OK
3.2    OC3    Clear - OK
3.3    OC3    Clear - OK
5.1    T3     Clear - OK
5.2    T3     Clear - OK
```

Last Command: upln 3.3

Next Command:

Note Note: The initial command to up a trunk (**uptrk**) or to up a line (**upln**) on the BXM card configures all the ports of the card to be either trunks or lines (UNI port access), respectively. (Comment: This note may be subject to change.) Following the **upln** command at each port, the **upport** command is used to activate a port for UNI access.

An example of the **cnfln** command follows:

```
pubsbsp1      TN      YourID:1      BPX 15      8.5      Jan. 23 1997 02:24 GMT

LN   3.3 Config   OC3   [353208cps]      BXM slot:   3
Loop clock:           No           Idle code:           7F hex

Line framing:         --
coding:               --
CRC:                  --
recv impedance:      --
E1 signalling:       --
encoding:             --
T1 signalling:       --
                    cable type:         --
                    length:             --
                    HCS Masking:         Yes
                    Payload Scramble:    Yes
                    Frame Scramble:      Yes
                    Cell Framing:        STS-3C

56KBS Bit Pos:       --
pct fast modem:      --
```

This Command: cnfln 3.3

Loop clock (N):

An example of the **cnfport** command for port 3 of a BXM card in slot 3 follows:

```
pubsbpx1      TN      YourID:1      BPX 15      8.5      Jan. 23 1997 02:25 GMT

Port:         3.3      [INACTIVE]
Interface:    LM-BXM
Type:         UNI      %Util Use:      Disabled
Speed:        353208 (cps)
Shift:        SHIFT ON HCF (Normal Operation)
VBR Queue Depth: 5000

Protocol:     NONE
SVC Channels: 0
SVC VPI Min: 0
SVC VPI Max: 0
SVC Bandwidth: 0 (c/s)
```

This Command: cnfport 3.3

NNI Cell Header Format? [N]:

An example of the **cnfportq** command follows:

```
pubsbpx1      TN      YourID:1      BPX 15      8.5      Jan. 23 1997 02:27 GMT

Port:         3.3      [INACTIVE]
Interface:    LM-BXM
Type:         UNI
Speed:        353208 (cps)

SVC Queue Pool Size: 0
CBR Queue Depth: 600
CBR Queue CLP High Threshold: 80%
CBR Queue CLP Low Threshold: 60%
CBR Queue EFCI Threshold: 80%
VBR Queue Depth: 5000
VBR Queue CLP High Threshold: 80%
VBR Queue CLP Low Threshold: 60%
VBR Queue EFCI Threshold: 80%
ABR Queue Depth: 20000
ABR Queue CLP High Threshold: 80%
ABR Queue CLP Low Threshold: 60%
ABR Queue EFCI Threshold: 80%
```

This Command: cnfportq 3.3

SVC Queue Pool Size [0]:

An example of the **upport** command follows:

```
pubsbpx1      TN      YourID:1      BPX 15      8.5      Jan. 23 1997 02:28 GMT

Port:         3.3      [ACTIVE ]
Interface:    LM-BXM
Type:         UNI      %Util Use:      Disabled
Speed:        353208 (cps)
Shift:        SHIFT ON HCF (Normal Operation)
VBR Queue Depth: 5000

Protocol:     NONE
SVC Channels:          0
SVC VPI Min:          0
SVC VPI Max:          0
SVC Bandwidth:        0 (c/s)
```

Last Command: upport 3.3

Next Command:

An example of the **cnfcls** command for class 1 follows:

```
pubsbpx1      TN      YourID:1      BPX 15      8.5      Jan. 23 1997 02:31 GMT

                        ATM Connection Classes

Class: 1
  PCR(0+1)    % Util    MCR          CDVT(0+1)    AAL5 FBTC FST  VSVD
96000/96000  100/100 96000/96000  10000/10000      n      n      n

Description: "Default ABR 96000"
```

This Command: cnfcls 1

Enter class type (VBR, CBR, UBR, ABR, ATFR):

An example of the **cnfcls** command for class 2 follows:

```
pubsbpx1      TN      YourID:1      BPX 15      8.5      Jan. 23 1997 02:33 GMT

                          ATM Connection Classes
Class: 2
  PCR(0+1)    % Util    CDVT(0+1)    AAL5 FBTC    SCR    Type: VBR
1000/1000    100/100    10000/10000    n    1000/1000

  MBS        Policing
1000/1000    3

  Description: "Default VBR 1000 "
```

This Command: cnfcls 2

Enter class type (VBR, CBR, UBR, ABR, ATFR):

An example of the **addcon** command for a VBR connection 3.1.105.55 that originates at port 1 of a BXM card in slot 3 follows:

```
pubsbpx1      TN      YourID:1      BPX 15      8.5      Jan. 23 1997 02:39 GMT

From          Remote      Remote      State  Type      Route
3.1.105.55    NodeName    Channel     Ok     vbr       Avoid COS 0
3.1.105.55    pubsbpx1    3.2.205.65  Ok     vbr
3.2.201.61    pubsbpx1    3.1.101.51  Ok     abr
3.2.201.62    pubsbpx1    3.1.101.52  Ok     abr
3.2.203.63    pubsbpx1    3.1.103.53  Ok     abr
3.2.204.64    pubsbpx1    3.1.104.54  Ok     abr
3.2.205.65    pubsbpx1    3.1.105.55  Ok     vbr
5.1.30.120    pubsbpx1    5.2.60.240  Ok     abr
5.1.31.121    pubsbpx1    5.2.61.241  Ok     abr
5.1.32.122    pubsbpx1    5.2.62.242  Ok     abr
5.1.33.123    pubsbpx1    5.2.63.242  Ok     abr
5.2.60.240    pubsbpx1    5.1.30.120  Ok     abr
5.2.61.241    pubsbpx1    5.1.31.121  Ok     abr
5.2.62.242    pubsbpx1    5.1.32.122  Ok     abr
```

Last Command: addcon 3.1.105.55 pubsbpx1 3.2.205.65 v * * * * *

Next Command:

Command Line Interface Examples

An example of the **cnfcon** command for a VBR connection 3.1.105.55 follows.

```
pubsbpx1      TN      YourID:1      BPX 15      8.5      Jan. 23 1997 02:41 GMT

Conn:  3.1.105.55      pubsbpx1      3.2.205.65      vbr
Description:

      PCR(0+1)      % Util      CDVT(0+1)      AAL5 FBTC      SCR
      50/50      100/100      250000/250000      n      50/50

      MBS      Policing
      1000/1000      3
```

This Command: `cnfcon 3.1.105.55`

PCR(0+1) [50/50]:

An example of the **addcon** command for an ABR connection follows. In this case, the choice to accept the default parameters was not accepted, and individual parameters were configured for a connection using ABR standard VSVD flow control.

```
pubsbpx1      TN      YourID      BPX 15      8.5      Jan. 21 1997 01:10 GMT

From      Remote      Remote      State      Type      Route
3.1.104.54      RemoteName      Channel      Avoid COS O
3.1.104.54      pubsbpx1      3.2.204.64      Ok      abr
3.2.201.61      pubsbpx1      3.1.101.51      Ok      abr
3.2.201.62      pubsbpx1      3.1.101.52      Ok      abr
3.2.203.63      pubsbpx1      3.1.103.53      Ok      abr
3.2.204.64      pubsbpx1      3.1.104.54      Ok      abr
5.1.30.120      pubsbpx1      5.2.60.240      Ok      abr
5.1.31.121      pubsbpx1      5.2.61.241      Ok      abr
5.1.32.122      pubsbpx1      5.2.62.242      Ok      abr
5.1.33.123      pubsbpx1      5.2.63.242      Ok      abr
5.2.60.240      pubsbpx1      5.1.30.120      Ok      abr
5.2.61.241      pubsbpx1      5.1.31.121      Ok      abr
5.2.62.242      pubsbpx1      5.1.32.122      Ok      abr
5.2.63.242      pubsbpx1      5.1.33.123      Ok      abr
```

This Command: `addcon 3.1.104.54 pubsbpx1 3.2.204.64 abr 100/100 95/95 50/50 * e d e d 70/70 * 3 * 80/80 60/60 30/30 65/65 * 100 16 16 32 10 *`

Add these connections (y/n)? `y`

An example of the **cnfcon** command for an ABR connection follows:

```
pubsbpx1      TN      YourID      BPX 15      8.5      Jan. 21 1997 01:10 GMT

Conn: 3.1.104.54      pubsbpx1      3.2.204.64      abr
Description:

      PCR(0+1)      % Util      MCR      CDVT(0+1)      AAL5 FBTC FST      VSVD
      100/100      95/95      50/50      250000/250000      y      n      y

FCES      SCR      MBS      Policing      VC Qdepth      CLP Hi      CLP Lo      EFCI
n      70/70      1000/1000      3      16000/16000      80/80      60/60      30/30

      ICR      ADF Trm      RIF      RDF      Nrm      FRTT      TBE
      65/65      1000 100      16      16      32      10      1048320
```

This Command: `cnfcon 3.1.104.54`

PCR(0+1) [100/100]:

An example of the **cnfabrparm** command follows:

```
pubsbpx1      TN      YourID      BPX 15      8.5      Feb. 8 1997 00:21 GMT

ABR Configuration for BXM in slot 3

Egress CI Control : N
ER Stamping       : N
Weighted Queueing : N
```

Last Command: `cnfabrparm 3`

Next Command:

An example of the **dsplns** command follows:

```
pubsbpx1      TN      YourID      BPX 15      8.5      Feb. 8 1997  00:22 GMT

Line   Type   Current Line Alarm Status
3.1    OC3    Clear - OK
3.2    OC3    Clear - OK
3.3    OC3    Clear - OK
3.4    OC3    Clear - OK
5.1    T3     Clear - OK
5.2    T3     Clear - OK
```

Last Command: dsplns

Next Command:

Configuring the BPX for SVCs

During the configuration of BPX Service Node interfaces, you must make sure that the BPX IP address, SNMP parameters, and Network IP address are set consistent with your local area network (Ethernet LAN). Use the following BPX commands to set these parameters:

- **cnflan**--This is a Super User level command and must be used to configure the BPX BCC LAN port IP address and subnet mask.
- **cnfsnmp**--This command is used to configure the SNMP Get and Set community strings for the BPX as follows:
 - Get Community String = Public
 - Set Community String = Private
 - Trap Community String = Public.
- **cnfnwip**--This is a Super User level command which is used to configure the virtual IP network (IP relay) among BPX Service Nodes.
- **cnfstatmast**--This command is used to define the IP address for routing messages to and from the Statistics Manager in StrataView Plus.

The use of these commands is covered in the *Cisco StrataCom Command Reference* or the *Cisco StrataCom Super User Command Reference*. Super User commands must only be used by authorized personnel, and must be used carefully.

Configuring the AXIS

AXIS installation and configuration are covered in the Cisco StrataCom AXIS Reference. During the configuration of BPX Service Node interfaces, you must make sure that the AXIS IP address is set up consistent with your local area network (Ethernet LAN). Use the following AXIS command to set the proper IP addresses:

cnfifip “-ip <ip address> -if <interface type> -msk <subnet mask address> -bc <broadcast address>”

The use of this command is covered in the *Cisco StrataCom AXIS Command Reference*

Resource Partitioning

Resources on BPX Service Node UNI ports and NNI trunks have to be divided between SVCs and PVCs. This is known as resource partitioning and is done through the Command Line Interface for the BPX and the AXIS.

This section provides procedures for:

- UNI Port Resource Partitioning, BXM and ASI
- NNI or Trunk Resource Partitioning, BXM and BNI

Note Resource partitioning also has to be done for the line between the ESP ATM NIC and the BXM in the BPX. Refer also to the *ESP Service Node Installation and Operations* document.

ASI SVC Resource Partitioning

A BPX ATM Service Interface (ASI) card which will support ATM SVCs will have to be added and upped like a standard PVC port. Before adding connections, an ASI line is upped with the **upln** command and configured with the **cnfport** command and upped with the **upport** command. Complete details on using the BPX command line interface and applicable commands are described in the *Cisco StrataCom BPX Reference* and *Command Reference* manuals. In addition, the *Cisco StrataCom System Overview* provides conceptual information about ATM connections. These procedures will concentrate on those commands that are specific to SVC resource partitioning.

Before partitioning SVC resources, you must have determined which ASI will support ATM SVCs. The ASI will have to have its resources partitioned to support SVCs. The following resources must be partitioned for each ASI UNI port:

- SVC Channels
- SVC VPI Min
- SVC VPI Max
- SVC Bandwidth
- SVC Queue Depth

To partition the ASI UNI port, follow these steps:

- Step 1** Log in to the BPX
- Step 2** Using the **upln** and **upport** commands, up the line and port which are going to be connected to ATM CPE.
- Step 3** Make sure the port is configured as UNI.
- Step 4** Enter the **cnfport <port num>** command, as illustrated in Figure 2-14:

Figure 2-14 ASI cnfport Command

```

cslab1      IN  StrataCom      BPX 15  8,4,#6  Apr. 19 1997 16:11 GMT
Port:      2.1  [FAILED ]
InterFace: HNF-2
Type:      UNI              XUtil Use:  Disabled
Speed:     353208 (cps)
Shift:     SHIFT ON HCF (Normal Operation)
SVC Queue Depth: 10

Protocol:  NONE
SVC Channels:          1000
SVC VPI Hsnt:         20
SVC VPI Hsxt:         1000
SVC Bandwidth:        20000 (cps)

-----
This Command: cnfport 2.1 N H N N 1000 20 1000 _
SVC Bandwidth [20000]: █
  
```

Note Figure 2-14 displays a screen with the Protocol parameter set to None. If Protocol had been set to LMI or ILMI, the LMI parameters would also appear on the screen. The SVC parameters that need to be configured will remain the same, however.

- Step 5** Configure the desired SVC Channels, SVC VPI Min, SVC VPI Max, and SVC Bandwidth as desired.
- Step 6** Next configure the SVC Port Queue depth with the **cnfportq** <port num> command. shown in Figure 2-15.

Figure 2-15 ASI cnfportq Command

```

b01ab03      [In] StrataCom      [BPX 15]  8.4.06  [Apr. 19 1997 16:08 GMT]
Port:        2,1      [FAILED] 1
Interface:   MMF-2
Type:        UNI
Speed:      353208 <cps>

SVC Queue Pool Size:      200
CBR Queue Depth(64-cell blks):16
CBR Queue CLP High Threshold: 80%
CBR Queue CLP Low Threshold: 60%
CBR Queue EFCI Threshold:  80%
VBR Queue Depth(64-cell blks):50
VBR Queue CLP High Threshold: 80%
VBR Queue CLP Low Threshold: 60%
VBR Queue EFCI Threshold:  80%
ABR Queue Depth(64-cells blks):228
ABR Queue CLP High Threshold: 80%
ABR Queue CLP Low Threshold: 60%
ABR Queue EFCI Threshold:  80%

-----
This Command: cnfportq 2,1 _
SVC Queue Pool Size [200]: █
    
```

- Step 7** Configure the SVC Queue Pool Size with this menu. Other parameters are for PVCs.
- Step 8** Repeat SVC resource partitioning for every ASI port that you want to support SVCs in the BPX Service Node.

BXM SVC Resource Partitioning

A BXM card used as a UNI port can be configured to support ATM SVCs. The BXM will have to be added and upped like a standard PVC port. The BXM port will have to be upped as a line (upln) to function as a UNI port.

Note The initial command to up a trunk (**uptrk**) or to up a line (**upln**) on the BXM configures all the physical ports on a BXM card to be either trunks or ports. They can not be inter-mixed.

For additional information on using the BPX command line interface and applicable commands, refer to the *Cisco StrataCom Command Reference* manual. In addition, the *Cisco StrataCom System Overview* provides conceptual information about ATM connections and services. These procedures will concentrate on those commands that are specific to SVC resource partitioning.

Before partitioning SVC resources, you must determine which BXM UNI ports will support ATM SVCs. The BXM must have its resources partitioned to support SVCs. The following resources must be partitioned:

- SVC Channels
- SVC VPI Min
- SVC VPI Max
- SVC Bandwidth
- SVC Queue Pool Size.

To partition the BXM port, follow these steps:

- Step 1** Log in to the BPX.
- Step 2** Using the upln and upport commands, up the line and port which is going to be connected to ATM CPE.
- Step 3** Make sure the port is configured as UNI.
- Step 4** Enter the **cnfport <port num>** command, shown in Figure 2-16:

Figure 2-16 BXM cnfport Command

```
StrataCom 8.4.a6 Apr. 19 1997 17:43 GMT
Port: 5.1 [ACTIVE ]
InterFace: LN-BRM
Type: UNI XUtil Use: Disabled
Speed: 353208 <cps>
Shift: SHIFT ON HCF <Normal Operation>
SIG Queue Depth: 640
Protocol: NONE
SVC Channels: 1000
SVC VPI Min: 0
SVC VPI Max: 200
SVC Bandwidth: 200000 <cps>

-----
This Command: cnfport 5.1 ...
NWJ Cell Header Format? (N):
```

- Step 5** Configure the SVC Channels, SVC VPI Min, SVC VPI Max, and SVC Bandwidth as desired.
- Step 6** Next you need to configure the SVC Port Queue depth with the cnfportq <portnum> command shown in Figure 2-17.

Figure 2-17 BXM cnfportq Command

```

StrotaCom 8.4.06 Feb. 19 1997 17:55 GMT
Port: 5,1 [ACTIVE 1]
Interface: LH-BM
Type: UNI
Speed: 353208 <ops>

SVC Queue Pool Size: 200
CBR Queue Depth: 600
CBR Queue CLP High Threshold: 80%
CBR Queue CLP Low Threshold: 60%
CBR Queue EFCI Threshold: 80%
VBR Queue Depth: 5000
VBR Queue CLP High Threshold: 80%
VBR Queue CLP Low Threshold: 60%
VBR Queue EFCI Threshold: 80%
ABR Queue Depth: 20000
ABR Queue CLP High Threshold: 80%
ABR Queue CLP Low Threshold: 60%
ABR Queue EFCI Threshold: 30%

This Command: cnfportq 5,1 _
SVC Queue Pool Size [200]: █

```

- Step 7** Configure the SVC Queue Pool Size parameter to a value greater than 0 (zero); the default is 0 and needs to be changed for SVCs to operate.
- Step 8** Partition the SVC resources for every BXM which is to support ATM SVCs in the BPX Service Node.

NNI Trunk SVC Resource Partitioning

The BPX has two types of trunk cards which may have their resources partitioned to support SVCs.

- BNI
- BXM

Note It is important to reserve the maximum number of channels before SVCs or PVCs are in use, because SVC partitioning parameters may not be changed if any SVC or PVC is in use on the entire card.

BNI Trunk SVC Resource Partitioning

When the BNI is used as a trunk in a BPX Service Node network, it will have to have its resources partitioned to support SVCs. The BNI is described in the Cisco StrataCom BPX Reference. Complete details on using the BPX command line interface and applicable commands are described in the *Cisco StrataCom BPX Reference* and *Command Reference* manuals. In addition, the *Cisco StrataCom System Overview* provides conceptual information about ATM connections and services. These procedures will concentrate on those commands that are specific to SVC resource partitioning.

The following BNI trunk resources must be partitioned for SVCs:

- SVC Channels
- SVC VPI Min
- SVC VPI Max
- SVC Bandwidth
- SVC Queue Pool Size.

To partition the BNI trunk resources, follow these steps:

- Step 1** Log in to the BPX
- Step 2** Up the trunk with **uptrk** <trunk_num> command.
- Step 3** Enter the **cnftrk** <trk num> command as shown in Figure 2-18:

Figure 2-18 BNI cnftrk Command

```

ipocvcl  [IN] StrataCom  [BPX 12] 8,4,e6  [Date/Time Not Set]
TRK 1,1 Config  DCS [353207cps] BNI-155 slot: 1
Line framing: STS-3C SVC Bandwidth: 300000 cps
Transmit Rate: 353200 Restrict OC traffic: No
Subrate interface: -- Line framing: STM-1
Subrate data rate: -- coding: --
Line DS-0 map: -- CRC: --
Pass sync: Yes rcv impedance: --
Loop clock: No cable type: --
Statistical Reserve: 1000 cps length: --
Idle code: 7F hex HCS Masking: Yes
Max Channels/Port: -- Payload Scramble: Yes
Connection Channels: 15050 Frame Scramble: No
Valid Traffic Classes: V,TS,NTS,FR,FST,CBR,VBR,ABR Virtual Trunk Type: --
SVC Channels: 1000 Virtual Trunk VPI: --
Beroute delay time:
Last Command: cnftrk 1,1 Y, N, 1000 7F V,TS,NTS,FR,FST,CBR,VBR,ABR N
Next Command:

```

- Step 4** Configure the SVC Channels and SVC Bandwidth as desired.
- Step 5** Next configure the SVC Queue depth with **cnftrkparms** <trunk_num> command shown in Figure 2-19:

Figure 2-19 BNI cnftrkparm Command

```

stratcom 8.4.e6
-----
TRK 1.1 Parameters
1 Q Depth - Voice [ 886] (Dec) 15 Q Depth - CBR [ 600] (Dec)
2 Q Depth - Non-TS [ 1281] (Dec) 16 Q Depth - VBR [ 1000] (Dec)
3 Q Depth - TS [ 1000] (Dec) 17 Q Depth - ABR [10000] (Dec)
4 Q Depth - EData A [ 1000] (Dec) 18 Low CLP - CBR [ 100] (X)
5 Q Depth - EData B [ 8000] (Dec) 19 High CLP - CBR [ 100] (X)
6 Q Depth - High Pri [ 1000] (Dec) 20 Low CLP - VBR [ 100] (X)
7 Max Age - Voice [ 20] (Dec) 21 High CLP - VBR [ 100] (X)
8 Red Alw - I/O (Dec) [ 2500 / 10000] 22 Low CLP - ABR [ 60] (X)
9 Yel Alw - I/O (Dec) [ 2500 / 10000] 23 High CLP - ABR [ 80] (X)
10 Low CLP - EData A [ 100] (X) 24 EFCN - ABR [ 30] (X)
11 High CLP - EData A [ 100] (X) 25 SVC Queue Pool Size [ 5655] (Dec)
12 Low CLP - EData B [ 25] (X)
13 High CLP - EData B [ 75] (X)
14 EFCN - EData B [ 30] (X)

This Command: cnftrkparm 1.1 _
Which parameter do you wish to change: 25

```

Step 6 Configure the SVC Queue Pool Size as desired.

Step 7 Partition the SVC resources for all the other BNIs in your BPX Service Node. This includes the BNI that is used to connect an AXIS shelf to a BPX when they are to be used for SVC connections.

BXM Trunk SVC Resource Partitioning

When the BXM is used as a trunk in a BPX Service Node network, it needs to have its resources partitioned to support SVCs. The BXM card will have to be upped as a trunk (**uptrk**).

Note The initial command to up a trunk (**uptrk**) or to up a line (**upln**) on the BXM configures all the physical ports on the card to be either lines or trunks. They can not be inter-mixed.

For additional information on using the BPX command line interface and applicable commands refer to the *Cisco StrataCom Command Reference* manual. In addition, the *Cisco StrataCom System Overview* provides conceptual information about ATM connections and services. These procedures concentrate on those commands that are specific to SVC resource partitioning.

The following BXM trunk resources must be partitioned for SVCs:

- SVC Channels
- SVC Bandwidth
- SVC Queue Pool Size

To partition the BXM trunk resources for SVCs, follow these steps:

- Step 1** Log in to the BPX
- Step 2** Make sure the BXM has been upped as a trunk with **uptrk <trunk_num>** command.
- Step 3** Enter the **cnftrk <trk num>** command, shown in Figure 2-20:

Figure 2-20 BXM cnftrk Command

```

lab1 StrataCom BPX 15 8.4.w6 Apr. 19 1997 18:49 GMT
TRK 13.1 Config DC3 (304301cps) BSM slot: 13
Transmit Rate: 393208 Line framing: ST5-3C
Subrate interFace: --- coding: ---
Subrate data rate: --- CRC: ---
Line BS-0 map: --- recv impedance: ---
Statistical Reserve: 1000 cps cable type: ---
Idle code: 7F hex length: ---
Max Channels/Port: 256 Pass sync: Yes
Connection Channels: 256 Loop clock: No
Valid Traffic Classes: MCS Masking: Yes
Y,TS,NTS,FR,FST,CBR,VBR,ABR Payload Scramble: Yes
SVC Channels: 2000 Frame Scramble: Yes
SVC Bandwidth: 300000 cps Virtual Trunk Type: ---
Restrict CC traffic: No Virtual Trunk VPI: ---
Link type: Terrestrial Deroute delay time: 0 seconds

This Command: onFtrk 13,1 ..
Stat Reserve (1000): █
    
```

- Step 4** Configure the SVC Channels and SVC Bandwidth as desired.

Step 5 Next configure the SVC Queue depth with `cnftrkparms <trunk_num>` command shown in Figure 2-21:

Figure 2-21 BXM cnftrkparm Command

```

to:labl      TN      StrataCom      BPX 15      8.4.a6      Apr. 15 1997 18:53 GMT
BX 13.1 Parameters
1 Q Depth - Voice      [ 885] (Dec)      15 Q Depth - CBR      [ 500] (Dec)
2 Q Depth - Non-TS     [ 1324] (Dec)     16 Q Depth - VBR      [ 5000] (Dec)
3 Q Depth - TS         [ 1000] (Dec)     17 Q Depth - ABR      [20000] (Dec)
4 Q Depth - BData A    [10000] (Dec)     18 Low CLP - CBR      [ 100] (Z)
5 Q Depth - BData B    [10000] (Dec)     19 High CLP - CBR     [ 100] (Z)
6 Q Depth - High Prt   [ 1000] (Dec)     20 Low CLP - VBR      [ 100] (Z)
7 Max Age - Voice     [ 20] (Dec)       21 High CLP - VBR     [ 100] (Z)
8 Red Alm - I/O (Dec) [ 2500 / 10000] 22 Low CLP - ABR      [ 50] (Z)
9 Yel Alm - I/O (Dec) [ 2500 / 10000] 23 High CLP - ABR     [ 50] (Z)
10 Low CLP - BData A   [ 100] (Z)        24 EPCN - ABR         [ 30] (Z)
11 High CLP - BData A [ 100] (Z)        25 SVC Queue Pool Size [ 2000] (Dec)
12 Low CLP - BData B   [ 25] (Z)
13 High CLP - BData B [ 75] (Z)
14 EPCN - BData B     [ 30] (Dec)

This Command: cnftrkparm 13.1 ...

Which parameter do you wish to change: 25

```

Step 6 Configure the SVC Queue Pool Size as desired.

Step 7 Partition the SVC resources for all the other BXMs in the BPX Service Node.

ATM Connections

This chapter describes how ATM connection services are established by adding ATM connections between ATM service interface ports in the network using ATM standard UNI 3.1 and Traffic Management 4.0. It describes BXM and ASI card operation and summarizes ATM connection parameter configuration

The chapter contains the following:

- ATM Connection Services
- SVCs
- Traffic Management Overview
- ABR, Standard ATM Traffic Mgt 4.0
- ATM Connection Requirements
- ATM Connection Configuration
- Traffic Policing Examples
- LMI and ILMI Parameters

ATM Connection Services

ATM connection services are established by adding ATM connections between ATM service interface ports in the network. ATM connections can originate and terminate on the ASI (ATM Service Interface) cards, on BXM-T3/E3, BXM-155 (OC-3), and BXM-622 (OC-12) cards configured for port (service access) operation on the BPX, or on the AXIS shelf (using the AUSM card for the AXIS). Frame relay to ATM network interworking connections are supported between either BXM or ASI cards to the IPX, IGX, or AXIS. Frame relay to ATM service interworking connections are supported between either BXM or ASI cards to FRSM cards on the AXIS shelf.

Figure 3-1 is a depiction of ATM connections over a BPX network. It shows ATM connections via BXM-T3/E3, BXM-155, BXM-622, ASI-1, and ASI-155 cards, as well as over AXIS shelves. It also shows frame relay to ATM interworking connections over AXIS, IPX, and IGX shelves. For further information on the AXIS shelf, refer to the *AXIS Reference* document.

Figure 3-1 ATM Connections over a BPX Network

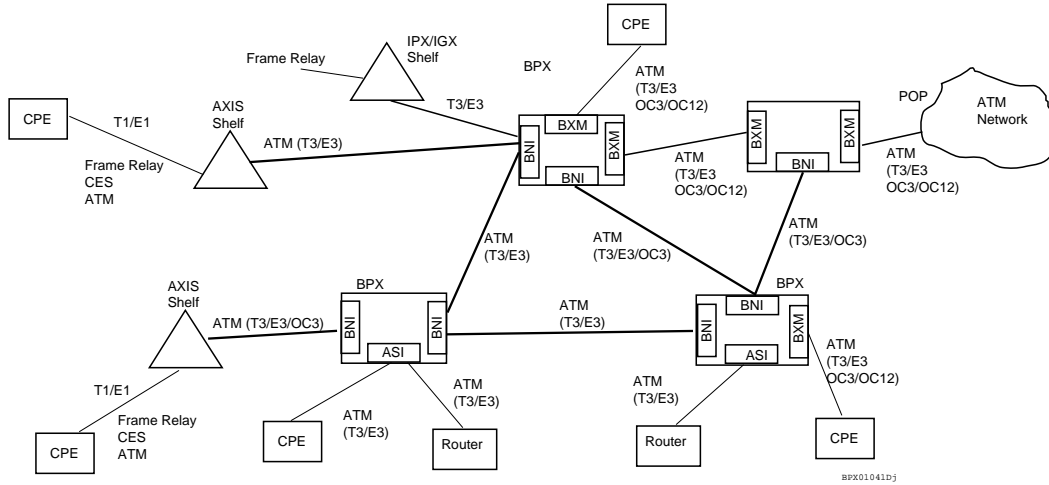

SVCs

When an Extended Services Processor (ESP) is co-located with a BPX Extended Services Node, ATM and Frame Relay Switched Virtual Circuits (SVCs) are supported in addition to Permanent Virtual Circuits (PVCs). For further information on ATM SVCs, refer to the *BPX Service Node Extended Processor Installation and Operation* document.

Traffic Management Overview

The ATM Forum Traffic Management 4.0 Specification defines five basic traffic classes:

- CBR (Constant Bit Rate)
- rt-VBR (Real-Time Variable Bit Rate)
- nrt-VBR (Non-Real Time Variable Bit Rate)
- UBR (Unspecified Bit Rate)
- ABR (Available Bit Rate)

Table 3-1 summarizes the major attributes of each of the traffic management classes:

Table 3-1 Standard ATM Traffic Classes

Attribute	CBR	rt-VBR	nrt-VBR	UBR	ABR
Traffic Parameters					
PCR & CDVT	x	x	x	x	x
SCR & MBS		x	x		
MCR					x
QoS Parameters					
Pk-to-Pk CDV	x	x			
Max CTD	x	x			
CLR	x	x	x		nw specific
Other Attributes					
Congestion Control Feedback					x

Traffic parameters are defined as:

- PCR (Peak Cell Rate in cells/sec): the maximum rate at which a connection can transmit
- CDVT (Cell Delay Variation Tolerance in usec): establishes the time scale over which the PCR is policed. This is set to allow for jitter (CDV) that is introduced for example, by upstream nodes.
- MBS (Maximum Burst Size in cells): is the maximum number of cells that may burst at the PCR but still be compliant. This is used to determine the BT (Burst Tolerance) which controls the time scale over which the SCR (Sustained Cell Rate) is policed.
- MCR (Minimum Cell Rate in cells per second): is the minimum cell rate contracted for delivery by the network.

QoS (Quality of Service) parameters are defined as:

- CDV (Cell Delay Variation): a measure of the cell jitter introduced by network elements
- Max CTD (Cell Transfer Delay): is the maximum delay incurred by a cell (including propagation and buffering delays).
- CLR (Cell Loss Ratio): is the percentage of transmitted cells that are lost.

Congestion Control Feedback:

- With ABR, provides a means to control flow based on congestion measurement.

ABR, Standard ATM Traffic Mgt 4.0

Standard ABR notes:

Standard ABR uses RM (Resource Management) cells to carry feedback information back to the connection's source from the connection's destination.

ABR sources periodically interleave RM cells into the data they are transmitting. These RM cells are called forward RM cells because they travel in the same direction as the data. At the destination these cells are turned around and sent back to the source as Backward RM cells.

The RM cells contain fields to increase or decrease the rate (the CI and NI fields) or set it at a particular value (the explicit rate ER field). The intervening switches may adjust these fields according to network conditions. When the source receives an RM cell it must adjust its rate in response to the setting of these fields.

VSVD Description

ABR sources and destinations are linked via bi-directional connections, and each connection termination point is both a source and a destination; a source for data that it is transmitting, and a destination for data that it is receiving. The forward direction is defined as from source to destination, and the backward direction is defined as from destination to source. Figure 3-2 shows the data cell flow in the forward direction from a source to its destination along with its associated control loop. The control loop consists of two RM cell flows, one in the forward direction (from source to destination) and the other in the backward direction (from destination to source).

The data cell flow in the backward direction from destination to source is not shown, nor are the associated RM cell flows. However, these flows are just the opposite of that shown in the diagram for forward data cell flows.

A source generates forward RM cells which are turned around by the destination and returned to the source as backward RM-cells. These backward RM-cells may carry feedback information from the network elements and/or the destination back to the source.

The parameter *Nrm* is defined as the maximum number of cells a source may send for each forward RM cell, i.e., one RM cell must be sent for every *Nrm*-1 data cells. Also, in the absence of *Nrm*-1 data cells, as an upper bound on the time between forward RM cells for an active source, an RM cell must be sent at least once every *Trm* msec.

BXM Connections

The BXM-T3/E3, BXM-155, and BXM-622 cards support ATM Traffic Management 4.0. The BXM cards are designed to support all the following service classes: Constant Bit Rate (CBR), Variable Bit Rate (VBR), Available Bit Rate (ABR with VS/VD, ABR without VS/VD, and ABR using Foresight), and Unspecified Bit Rate (UBR). ABR with VS/VD supports explicit rate marking and Congestion Indication (CI) control.

Figure 3-2 ABR VSVD Flow Control Diagram

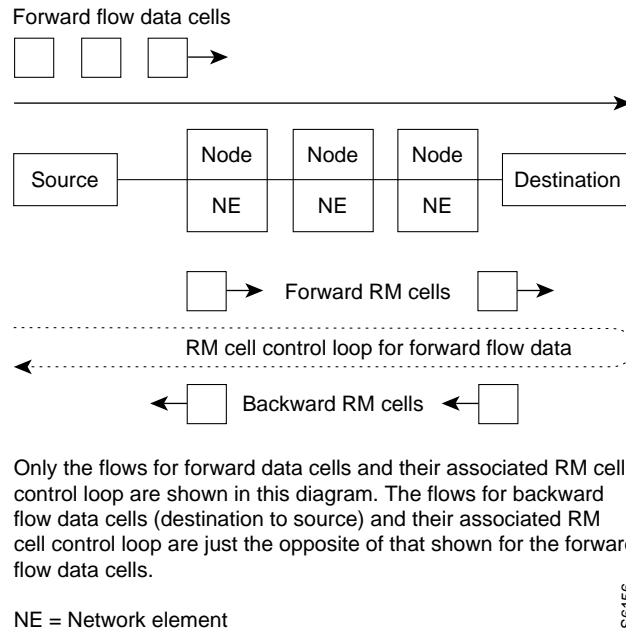

Only the flows for forward data cells and their associated RM cell control loop are shown in this diagram. The flows for backward flow data cells (destination to source) and their associated RM cell control loop are just the opposite of that shown for the forward flow data cells.

NE = Network element

S36156

ForeSight Congestion Control

ForeSight may be used for congestion control across BPX/IGX/IPX switches for connections that have one or both end points terminating on ASI-T3/E3 or BXM cards. The ForeSight feature is a proprietary dynamic closed-loop, rate-based, congestion management feature that yields bandwidth savings compared to non-ForeSight equipped trunks when transmitting bursty data across cell-based networks. The BXM cards also support the VSVD congestion control mechanism as specified in the ATM Traffic Management 4.0 standards.

ATM Connection Requirements

There are two connection addressing modes supported. The user may enter a unique VPI/VCI address in which case the BPX functions as a virtual circuit switch. Or the user may enter only a VPI address in which case all circuits are switched to the same destination port and the BPX functions as a virtual path switch in this case. The full ATM address range for VPI and VCI is supported. Virtual Path Connections are identified by an * in the VCI field. Virtual Circuit Connections specify both the VPI and VCI fields.

The VPI and VCI fields have significance only to the local BPX, and are translated by tables in the BPX to route the connection. Connections are automatically routed by the AutoRoute feature once the connection endpoints are specified.

ATM connections can be added using either the StrataView Plus Connection Manager or a node's command line interface (CLI). Typically, the StrataView Plus Connection Manager is the preferred method as it has an easy to use GUI interface. The CLI may be the method of choice in some special cases or during initial node setup for local nodes.

When adding ATM connections, first the access port and access service lines connecting to the customer CPE need to be configured. Also, the trunks across the network need to be configured appropriately for the type of connection. Following that the **addcon** command may be used to add a connection, first specifying the service type and then the appropriate parameters for the connection.

For example, when configuring a BXM for CPE connections, the BXM is configured for port mode, a line is upped with the **upln** command and configured with the **cnfln** command. Then the associated port is configured with the **cnfport** command and upped with the **upport** command. Following this, the ATM connections are added via the **addcon** command with the syntax.

Connection Routing

ATM connections for a BXM or ASI card are identified as follows:

- slot number (in the BPX shelf where the BXM or ASI is located)
- port number (one of the ATM ports on the BXM or ASI)
- Virtual Path Identifier (VPI)
- Virtual Circuit Identifier (VCI) – (* for virtual path connections).

The slot and port are related to the BPX hardware. Virtual path connections (VPCs) are identified by a “*” for the VCI field. Virtual circuit connections (VCCs) are identified by both a VPI and VCI field.

Connections added to the network are automatically routed once the end points are specified. This AutoRoute feature is standard with all BPX, IGX, and IPX nodes. The network automatically detects trunk failures and routes connections around the failures.

Addcon Command Syntax

The following parameters are entered for BXM **addcon** command. Depending upon the connection type, the user is prompted for the appropriate parameters as shown in the following:

```
addcon local_addr node remote_addr traffic_type...extended parameters
```

Field	Value	Description
local/remote_addr	slot.port.vpi.vci	desired VCC or VPI connection identifier
node		slave end of connection
traffic_type		Type of traffic, chosen from CBR, VBR, ABR, and UBR
extended parameters		The traffic management and performance parameters associated with an ATM connection.

Note The range of VPIs and VCIs reserved for PVC traffic and SVC traffic is configurable using the **cnfport** command. While adding connections, the system checks the entered VPI/VPC against the range reserved for SVC traffic. If there is a conflict, the **addcon** command fails with the message “VPI/VCI on selected port is reserved at local/remote end”.

ATM Connection Configuration

The following figures and tables describe the parameters used to configure ATM connections:

- Table 3-2, Traffic Policing Definitions.
 - This table describes the policing options that may be selected for ATM connection types: CBR, UBR, and VBR. The policing options for ABR are the same as for VBR.
- Table 3-3, Connection Parameter Default Settings and Ranges
 - This table specifies the ATM connection parameter ranges and defaults. Not all the parameters are used for every connection type. When adding connections, you are prompted for the applicable parameters, as specified in the prompt sequence diagrams included in Figure 3-3 through Figure 3-10.
- Table 3-4, Connection Parameter Descriptions
 - This table defines the connection parameters listed in Table 3-3.

The following figures list the connection parameters in the same sequence as they are entered when a connection is added:

- Figure 3-3, CBR Connection Prompt Sequence
- Figure 3-4, VBR Connection Prompt Sequence
- Figure 3-5, ATFR Connection Prompt Sequence
- Figure 3-6, ABR Standard Connection Prompt Sequence

The following figure shows the VSVD network segment and external segment options available when ABR Standard or ABR ForeSight is selected. ForeSight congestion control is useful when both ends of a connection do not terminate on BXM cards. At present, FCES (Flow Control External Segment) as shown in Figure 3-7 is not available for ABR with ForeSight.

- Figure 3-7, Meaning of VSVD and Flow Connection External Segments

The following figures list the connection parameters in the same sequence as they are entered when a connection is added:

- Figure 3-8, ABR ForeSight Connection Prompt Sequence
- Figure 3-9, ATFST Connection Prompt Sequence
- Figure 3-10, UBR Connection Prompt Sequence

Table 3-2 Traffic Policing Definitions

Connection Type	ATM Forum TM spec. 4.0 conformance definition	PCR Flow (1st leaky bucket)	CLP tagging (for PCR flow)	SCR Flow (2nd leaky bucket)	CLP tagging (for SCR flow)
CBR	CBR.1 when policing set to 4 (PCR Policing only)	CLP(0+1)	no	off	n/a
CBR	When policing set to 5 (off)	off	n/a	off	n/a
UBR	UBR.1 when CLP setting = no	CLP(0+1)	no	off	n/a
UBR	UBR.2 when CLP setting = yes	CLP(0+1)	no	CLP(0)	yes
VBR, ABR, ATFR, ATFST	VBR.1 when policing set to 1	CLP(0+1)	no	CLP(0+1)	no
VBR, ABR, ATFR, ATFST	VBR.2 when policing set to 2	CLP(0+1)	no	CLP(0)	no
VBR, ABR, ATFR, ATFST	VBR.3 when policing set to 3	CLP(0+1)	no	CLP(0)	yes
VBR, ABR, ATFR, ATFST	when Policing set to 4	CLP(0+1)	no	off	n/a
VBR, ABR, ATFR, ATFST	when Policing set to 5 for off)	off	n/a	off	n/a

Note 1: - For UBR.2, SCR = 0

Note 2:

- CLP = Cell Lost Priority
- CLP(0) means cells that have CLP = 0
- CLP(1) means cells that have CLP = 1
- CLP(0+1) means both types of cells: CLP = 0 & CLP = 1
- CLP(0) has higher priority than CLP(1)
- CLP tagging means to change CLP = 0 to CLP = 1, where CLP= 1 cells have lower priority

Table 3-3 Connection Parameters with Default Settings and Ranges

PARAMETER WITH [DEFAULT SETTING]	BXM T3/E3, OC3 & OC12 RANGE	ASI T3/E3 RANGE	ASI-155 RANGE
PCR(0+1)[50/50]	50- T3/E3 cells/sec 50 - OC3 50 - OC12	T3: MCR – 96000 E3: MCR – 80000 Limited to MCR – 5333 cells/sec for ATFR connections.	OC3 (STM1): 0 – 353200
%Util[100/100] for UBR [1/1]	0 - 100%	1 - 100%	1 - 100%
MCR[50/50]	cells/sec 6 - T3/E3OC3/OC12	T3: 0 – 96000 cells/sec E3: 0 – 80000 cells/sec	N/A
FBTC (AAL5 Frame Base Traffic Control): for VBR [disable] for ABR/UBR [enable] for Path connection [disable]	enable/disable	enable/disable	enable/disable
CDVT(0+1): for CBR [10000/10000], others [250000/250000]	0 - 5,000,000 usec	T3/E3 1 – 250,000 usecs.	OC3/STM1: 0 – 10000 usecs.
VSVD[disable]	enable/disable	enable/disable	Select disable, as only ABR w/o VSVD is supported.
FCES (Flow Control External Segment) [disable]	enable/disable	enable/disable	N/A
Default Extended Parameters[enable]	enable/disable	enable/disable	N/A
CLP Setting[enable]	enable/disable	enable/disable	enable/disable
SCR [50/50]	cells/sec 50 - T3/E3OC3/OC12	T3: MCR – 96000:T3 E3: MCR – 80000: E3 Limited to MCR – 5333 cells/sec for ATFR connections.	OC3/STM1: 0 – 353200
MBS [1000/1000]	1 - 5,000,000cells	T3/E3: 1 – 24000 cells	OC3 (STM1): 10 – 1000 cells
Policing[3] For CBR: [4]	1 - VBR.1 2 - VBR.2 3 - VBR.3 4 - PCR policing only 5 - off	1 - VBR.1 2 - VBR.2 3 - VBR.3 4 - PCR policing only 5 - off	1 - VBR.1 2 - VBR.2 3 - VBR.3 4 - PCR policing only 5 - off

PARAMETER WITH [DEFAULT SETTING]	BXM T3/E3, OC3 & OC12 RANGE	ASI T3/E3 RANGE	ASI-155 RANGE
ICR: max[MCR, PCR/10]	MCR - PCR cells/sec	MCR - PCR cells/sec	N/A
ADTF[1000]	62 - 8000 msec	1000 – 255000 msec.	N/A
Trm[100]	ABR std: 1 - 100 msec ABR (FST): 3 - 255 msec	20 – 250 msec.	N/A
VC QDepth [16000/16000] For ATFR/ATFST [1366/1366]	0 - 64140 cells	Applies to T3/E3 only ABR: 1 – 64000 cells ATFR: 1 – 1366 cells	ATFR: 1 – 1366 cells
CLP Hi [80/80]	0 - 100%	0 – 100%	N/A
CLP Lo/EPD [35/35]	0 - 100%	0 – 100%	N/A
EFCI [30/30] For ATFR/ATFST [100/100]	0 - 100%	0 – 100%	0 - 100%
RIF: For ForeSight: max[PCR/128, 10] For ABR STD[128]	If ForeSight, then in absolute (0 - PCR) If ABR then 2 ⁿ (1 - 32768)	If ForeSight, then in absolute (0 – PCR) If ABR, then 2 ⁿ (1 – 32768)	N/A
RDF: For ForeSight [93] For ABR STD [16]	If ForeSight, then % (0% - 100%) If ABR then 2 ⁿ (1 - 32768)	If ForeSight, then % (0% – 100%) If ABR, then 2 ⁿ (1 – 32768)	N/A
Nrm[32], BXM only	2 - 256 cells	N/A	N/A
FRTT[0], BXM only	0 - 16700 msec	N/A	N/A
TBE[1,048,320], BXM only	0 - 1,048,320 cells (different max range from TM spec. but limited by firmware for CRM(4095 only) where CRM=TBE/Nrm	N/A	N/A
IBS[0/0]	0 - 24000 cells	T3/E3 ABR: 0 - 24000 cells ATFR: 1 - 107 cells	0 - 999 cells

Table 3-4 Connection Parameter Descriptions

Parameter	Description
PCR	Peak cell rate: The cell rate which the source may never exceed
%Util	% Utilization; bandwidth allocation for: VBR, CBR, UBR it's PCR*%Util, for ABR it's MCR*%Util
MCR	Minimum Cell Rate: A minimum cell rate committed for delivery by network
CDVT	Cell Delay Variation Tolerance: Controls time scale over which the PCR is policed
FBTC (AAL5 Frame Basic Traffic Control)	To enable the possibility of discarding the whole frame, not just one non-compliant cell. This is used to set the Early Packet Discard bit at every node along a connection.
ForeSight	Proprietary flow control feature
VSVD	Virtual Source Virtual Destination: (see Meaning of VSVD and Flow Control External Segments, Figure 3-7)
FCES (Flow Control External Segments)	(see Meaning of VSVD and Flow Control External Segments, Figure 3-7)
SCR	Sustainable Cell Rate: Long term limit on the rate a connection can sustain
MBS	Maximum Burst Size: Maximum number of cells which may burst at the PCR but still be compliant. Used to determine the Burst Tolerance (BT) which controls the time scale over which the SCR is policed
Policing	(see definitions of Traffic Policing, Table 3-2)
VC QDepth	VC Queue Depth
CLP Hi	Cell Loss Priority Hi threshold (% of VC QMax)
CLP Lo/EPD	Cell Loss Priority Low threshold (% of VC QMax)/Early Packet Discard. If AAL5 FBTC = yes, then for the BXM card this is the EPD threshold setting. For ASI cards, regardless of the FBTC setting, this is the CLP Lo setting.
EFCI	Explicit Forward Congestion Indication threshold (% of VC QMax)
ICR	Initial Cell Rate: The rate at which a source should send initially and after an idle period
ADTF (ATM Forum TM 4.0 term)	The Allowed-Cell-Rate Decrease Factor: Time permitted between sending RM-cells before the rate is decreased to ICR
Trm (ATM Forum TM 4.0 term)	An upper bound on the time between forward RM-cells for an active source, i.e., RM cell must be sent at least every Trm msec
RIF (ATM Forum TM 4.0 term)	Rate Increase Factor: Controls the amount by which the cell transmission rate may increase upon receipt of an RM cell

Parameter	Description
RDF (ATM Forum TM 4.0 term)	<p>Rate Decrease Factor:</p> <p>Controls the amount by which the cell transmission rate may decrease upon receipt of an RM cell</p>
Nrm (ATM Forum TM 4.0 term), BXM only.	<p>Nrm</p> <p>Maximum number of cells a source may send for each forward RM cell, i.e. an RM cell must be sent for every Nrm-1 data cells</p>
FRTT (ATM Forum TM 4.0 term), BXM only.	<p>Fixed Round Trip Time: the sum of the fixed and propagation delays from the source to a destination and back</p>
TBE (ATM Forum TM 4.0 term), BXM only.	<p>Transient Buffer Exposure:</p> <p>The negotiated number of cells that the network would like to limit the source to sending during start-up periods, before the first RM-cell returns.</p>
IBS	Initial Burst Size

CBR Connections

The **CBR** (constant bit rate) category is a fixed bandwidth class. CBR traffic is more time dependent, less tolerant of delay, and generally more deterministic in bandwidth requirements. CBR is used by connections that require a specific amount of bandwidth to be available continuously throughout the duration of a connection. Voice, circuit emulation, and high-resolution video are typical examples of traffic utilizing this type of connection. A CBR connection is allowed to transmit cells at the peak rate, below the peak rate, or not at all. CBR is characterized by peak cell rate (PCR).

The parameters for a CBR connection are shown in Figure 3-3 in the sequence in which they occur during the execution of the **addcon** command. The CBR policing definitions are summarized in Table 3-5.

Figure 3-3 CBR Connection Prompt Sequence

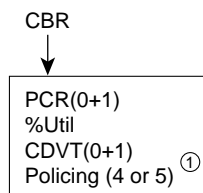

- ① For policing prompt:
4 = PCR policing only
5 = policing off

Note: BW allocation = (PCR)x(%Util) 30159

Table 3-5 CBR Policing Definitions

Connection Type	ATM Forum TM spec. 4.0 conformance definition	PCR Flow (1st leaky bucket)	CLP tagging (for PCR flow)	SCR Flow (2nd leaky bucket)	CLP tagging (for SCR flow)
CBR	CBR.1 when policing set to 4 (PCR Policing only)	CLP(0+1)	no	off	n/a
CBR	When policing set to 5 (off)	off	n/a	off	n/a

VBR and ATFR Connections

VBR Connections

VBR (variable bit rate) connections may be classified as rt-VBR or nrt-VBR connections.

The rt-VBR (real-time variable bit rate) category is used for connections that transmit at a rate varying with time and that can be described as bursty, often requiring large amounts of bandwidth when active. The rt-VBR class is intended for applications that require tightly constrained delay and delay variation. An example of rt-VBR is video conferencing which requires real-time data transfer with bandwidth requirements that can vary in proportion to the dynamics of the video image at any given time. The rt-VBR category is characterized in terms of PCR, SCR (sustained cell rate), and MBS (maximum burst size).

The nrt-VBR (non-real time variable bit rate) category is used for connections that are bursty but are not constrained by delay and delay variation boundaries. For those cells in compliance with the traffic contract, a low cell loss is expected. Non-time critical data file transfers are an example of an nrt-VBR connection. A nrt-VBR connection is characterized by PCR, SCR, and MBS.

Configuring VBR connections. The characteristics of rt-VBR or nrt-VBR are supported by appropriately configuring the parameters of the VBR connection.

The parameters for a VBR connection are shown in Figure 3-4 in the sequence in which they occur during the execution of the **addcon** command. The VBR policing definitions are summarized in Table 3-6.

Figure 3-4 VBR Connection Prompt Sequence

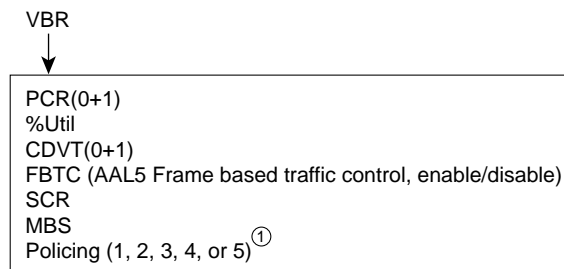

- ① For policing prompt:
- 1 = VBR.1
 - 2 = VBR.2
 - 3 = VBR.3
 - 4 = PCR policing only
 - 5 = policing off

Note: BW allocation = (PCR)x(%Util)

S6160

Table 3-6 VBR Policing Definitions

Connection Type	ATM Forum TM spec. 4.0 conformance definition	PCR Flow (1st leaky bucket)	CLP tagging (for PCR flow)	SCR Flow (2nd leaky bucket)	CLP tagging (for SCR flow)
VBR, ABR, ATFR, ATFST	VBR.1 when policing set to 1	CLP(0+1)	no	CLP(0+1)	no
VBR, ABR, ATFR, ATFST	VBR.2 when policing set to 2	CLP(0+1)	no	CLP(0)	no
VBR, ABR, ATFR, ATFST	VBR.3 when policing set to 3	CLP(0+1)	no	CLP(0)	yes
VBR, ABR, ATFR, ATFST	when Policing set to 4	CLP(0+1)	no	off	n/a
VBR, ABR, ATFR, ATFST	when Policing set to 5 for off)	off	n/a	off	n/a

ATFR Connections

An **ATFR** (ATM to Frame Relay) connection is a frame relay to ATM connection and is configured as a VBR connection, with a number of the ATM and frame relay connection parameters being mapped between each side of the connection.

The parameters for an ATFR connection are shown in Figure 3-5 in the sequence in which they occur during the execution of the **addcon** command.

Figure 3-5 ATFR Connection Prompt Sequence

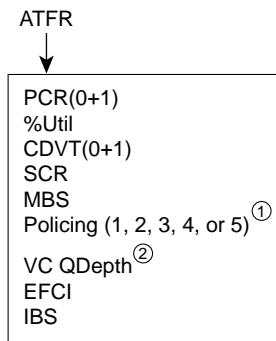

① For policing prompt:

- 1 = VBR.1
- 2 = VBR.2
- 3 = VBR.3
- 4 = PCR policing only
- 5 = policing off

② VC QDepth maps to VC Queue Max for frame relay

- EFCI maps to ECN for frame relay
- IBS maps to Cmax for frame relay

Note: FBTC (Frame based traffic control - AAL5, same as FGCR) is automatically set to yes.

S6161

ABR Notes

The term ABR is used to specify one of the following:

- ABR standard without VSVD (This is ABR standard without congestion flow control.)
 - Supported by BXM, ASI-T3 (& ASI-E3), and ASI OC3 cards.
- ABR standard with VSVD. (This is ABR standard with congestion flow control as specified by the ATM Traffic Management, Version 4.0)
 - Also, referred to as ABR.1
 - Supported only by BXM cards
 - Feature must be ordered.
- ABR with ForeSight congestion control
 - Also, referred to as ABR.FST
 - Supported by BXM and ASI-T3 (& ASI-E3) cards
 - Feature must be ordered.

ABR and ATFST Connections

ABR Connections

The **ABR** (available bit rate) category utilizes a congestion flow control mechanism to control congestion during busy periods and to take advantage of available bandwidth during less busy periods. The congestion flow control mechanism provides feedback to control the connections flow rate through the network in response to network bandwidth availability. The ABR service is not restricted by bounding delay or delay variation and is not intended to support real-time connections. ABR is characterized by: PCR and MCR.

Policing for ABR connections is the same as for VBR connections which are summarized in Table 3-6.

The ABR connections are configured as either ABR Standard (**ABRSTD**) connections or as ABR ForeSight (**ABRFST**) connections.

The parameters for an ABRSTD connection are shown in Figure 3-6 in the sequence in which they occur during the execution of the **addcon** command.

The ABRSTD connection supports all the features of ATM Standards Traffic Management 4.0 including VSVD congestion flow control.

VSVD and flow control with external segments are shown in Figure 3-7.

Figure 3-6 ABR Standard Connection Prompt Sequence

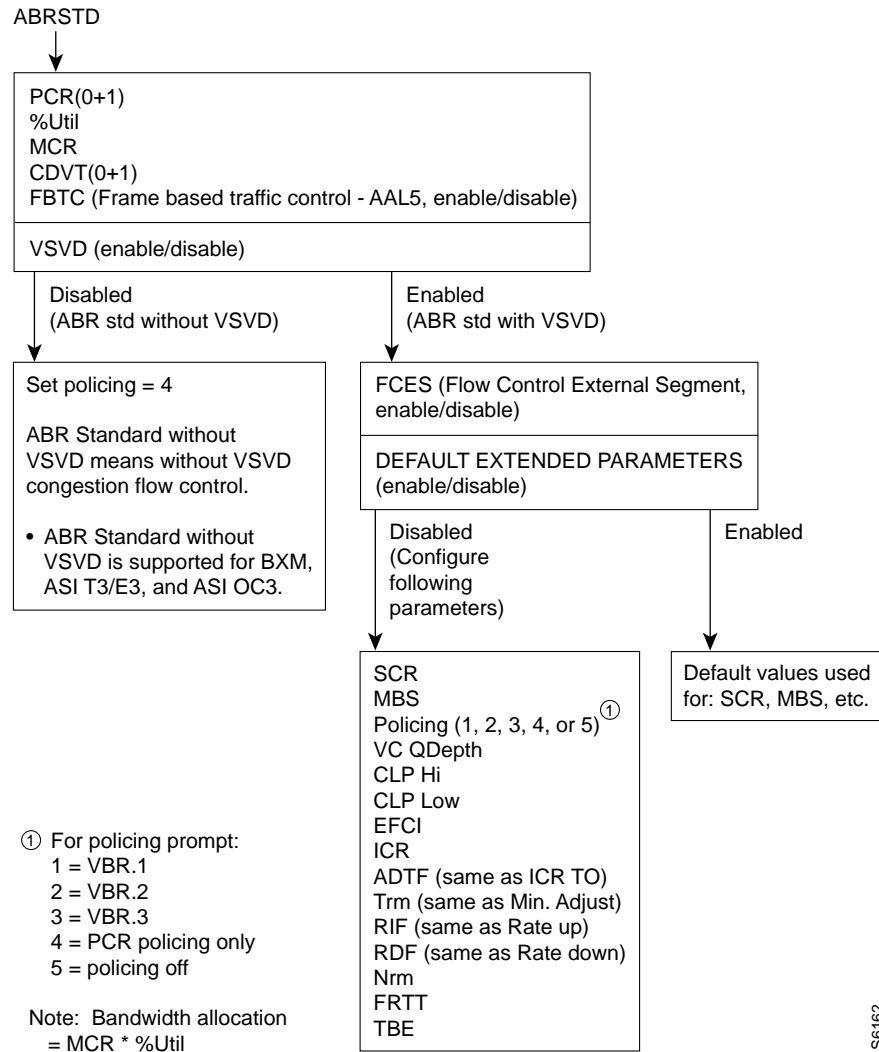
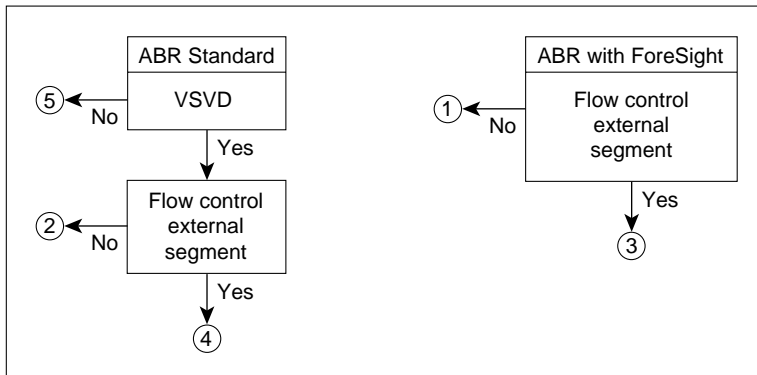
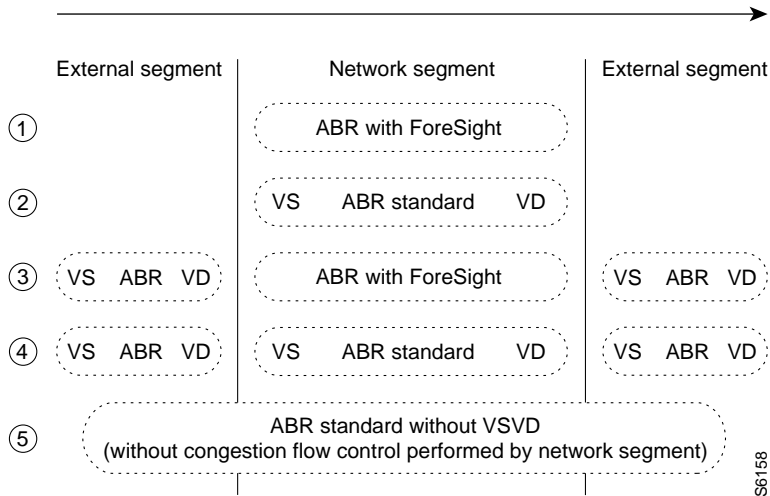

Figure 3-7 Meaning of VSVD and Flow Control External Segments



VS and VD shown below are for traffic flowing in direction of arrow. For the other direction of traffic, VS and VD are in the opposite direction.



ATFST Connections

The **ABRFST** connection uses the propriety ForeSight congestion control and is useful when configuring connections on which both ends do not terminate on BXM cards.

The parameters for an ABRFST connection are shown in Figure 3-8 in the sequence in which they occur during the execution of the **addcon** command.

Figure 3-8 ABR ForeSight Connection Prompt Sequence

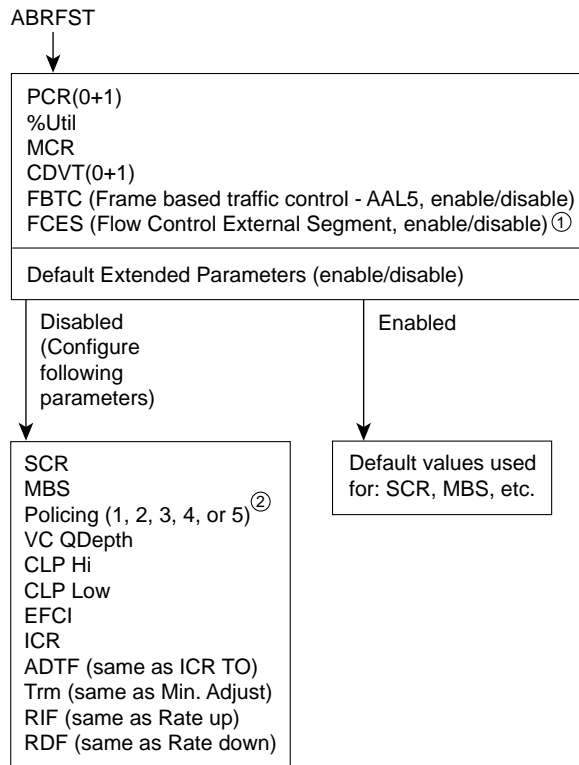

① At present, FCES is not available for ABR with ForeSight

② For policing prompt:
 1 = VBR.1
 2 = VBR.2
 3 = VBR.3
 4 = PCR policing only
 5 = policing off

Note: Bandwidth allocation
 = (MCR)x(%Util)

S6163

An **ATFST** connection is a frame relay to ATM connection that is configured as an ABR connection with ForeSight. ForeSight congestion control is automatically enabled when connection type ATFST is selected. A number of the ATM and frame relay connection parameters are mapped between each side of the connection.

The parameters for an ATFST connection are shown in Figure 3-9 in the sequence in which they occur during the execution of the **addcon** command.

Figure 3-9 ATFST Connection Prompt Sequence

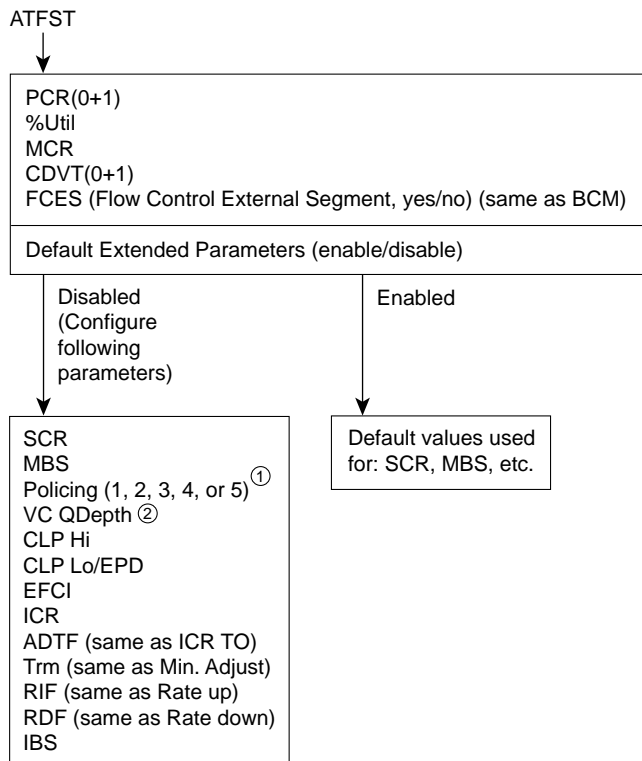

- ① For policing prompt:
 - 1 = VBR.1
 - 2 = VBR.2
 - 3 = VBR.3
 - 4 = PCR policing only
 - 5 = policing off

- ② VC QDepth maps to VC Queue max for frame relay.
EFCI maps to ECN for frame relay.
IBS maps to C max for frame relay.

Note: FBTC (Frame based traffic control - AAL5, same as FGCR) is automatically set to yes.

S6164

UBR Connections

The unspecified bit rate (**UBR**) connection service is similar to the ABR connection service for bursty data. However, UBR traffic is delivered only when there is spare bandwidth in the network. This is enforced by setting the CLP bit on UBR traffic when it enters a port.

Therefore, traffic is served out to the network only when no other traffic is waiting to be served first. The UBR traffic does not affect the trunk loading calculations performed by the switch software.

The parameters for a UBR connection are shown in Figure 3-10 in the sequence in which they occur during the execution of the **addcon** command.

The UBR policing definitions are summarized in Table 3-7.

Figure 3-10 UBR Connection Prompt Sequence

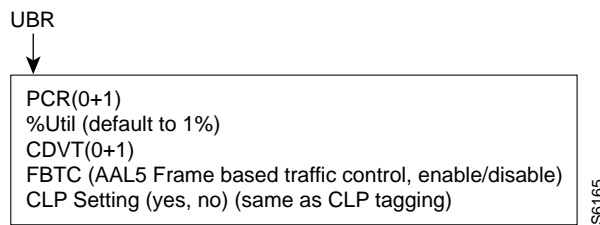

Table 3-7 UBR Policing Definitions

Connection Type	ATM Forum TM spec. 4.0 conformance definition	PCR Flow (1st leaky bucket)	CLP tagging (for PCR flow)	SCR Flow (2nd leaky bucket)	CLP tagging (for SCR flow)
UBR	UBR.1 when CLP setting = no	CLP(0+1)	no	off	n/a
UBR	UBR.2 when CLP setting = yes	CLP(0+1)	no	CLP(0)	yes

LMI and ILMI Parameters

The following is a listing of the LMI and ILMI parameters for the ASI:

For ILMI refer to Table 3-8:

Table 3-8 ILMI Parameters

Parameter	Description
VPI.VCI	VCCI for ILMI signaling channel equal 0.16
Polling Enabled	Keep-alive polling
Trap Enabled	VCC change of state traps
Polling Interval	Time between GetRequest polls
Error Threshold	Number of failed entries before ILMI link failure is declared.
Event Threshold	Number of successful polls before ILMI link failure is cancelled.
Addr Reg Enab	SVC Address Registration procedures enabled.

For the LMI refer to

Table 3-9 LMI Parameters

Parameter	Description
VPI.VCI	VCCI for LMI signaling channel equal 0.31
Polling Enable	Keep-alive polling
T393	Status Enquiry timeout value
T394	Update Status timeout value
T396	Status Enquiry polling timer
N394	Status Enquiry retry count
N395	Update Status retry count

Configuration and Management

This chapter contains preliminary configuration procedures. Refer to the Command Reference and the AXIS Reference Manual for more detailed information. Refer also to *Chapter 2, BXM T3/E3, 155, and 622* for configuration examples specific to the BXM cards.

This chapter contains the following:

- Initial Setup
- BPX Management
- IP Setup and IP Relay Configuration (Preliminary)
- Network Node Configuration (Preliminary)

The BPX node can be accessed through a local control port (over an RS-232 or Ethernet TCP/IP link). An administration screen from a control terminal or from the StrataView Plus Network Management Station (NMS) can issue BPX commands. Remote control terminal access is possible using a Virtual Terminal (vt) command if the node has been configured with a name and at least one trunk to the network has been established.

For frame relay connections in both tiered and non-tiered networks StrataView Plus provides end-to-end configuration management using the Connection Manager. When an IPX or IGX is configured as an Interface Shelf, it can not be reached by the vt command, and frame relay end-to-end connections are configured from StrataView Plus via the Connection Manager over an in-band LAN connection. (Note: Telnet can be used to access an interface shelf (e.g., IPX or IGX shelf or AXIS shelf) if a SV+ workstation is not available to provide in-band management.)

The only type of IPX and IGX shelf connections supported are frame relay to frame relay connections and frame relay interworking connections. However, on the IPX, all types of DAXCONS (connections in and out the same IPX shelf) are supported, voice, data, etc. For Release 8.5, the AXIS shelf includes frame relay interworking connections, ATM connections, CES connections, IMA, and FUNI connections.

Initial Setup

The basic tasks to configure an BPX are as follows:

- Set up the node
 - configure the node name (cnfname).
 - configure the time zone (cnftmzn).
 - configure date (cnfdate)
 - configure the LAN interface (cnflan).

- configure the auxiliary or terminal ports to support any necessary external devices such as a local printer, an autodial modem, or an external multiplexer attached to the unit (cnfprt, cnfterm, cnftermfunc).
- Set up the trunks to other routing nodes
 - verify the correct cards are in both the local and remote nodes (dspcds).
 - up the trunk at each node (uptrk).
 - configure any parameters required for the trunk at each node (cnftrk).
 - set up Y redundancy if desired (addyred)
 -
- **If using an IPX/IGX Interface Shelf, configure it as shelf**
 - Up the trunk from the AIT/BTM to the BPX using (uptrk). Shelf trunks for the IPX/IGX must be upped on both the Routing Hub and the Shelf before the Shelf can be joined to the Routing Network
 - Contact Customer Service to configure the IPX/IGX shelf option.
 - At the BPX, add the IPX/IGX as a shelf to the BPX (addshelf).

The following two examples are of the screens displayed when “dspnode” is entered at a BPX and at one of its IPX shelves, respectively. The “dspnode” screen displayed at the “hubone” bpx node shows that it is connected to the “shlf3ipx” node via BNI trunk 3.3. The “dspnode” screen displayed at the “shlf3ipx” node show that it is connected to the bpx via AIT trunk 8.

Example of dspnode at node “hubone” BPX15 showing feeder shelves

```
hubone          TN    edgar          BPX 15    8.5    Nov. 20 1996 08:09 PST
```

BPX Interface Shelf Information

Trunk	Name	Type	Alarm
1.2	shlf1Axis	AXIS	OK
1.3	shlf2Axis	AXIS	OK
3.1	shlf1IPX	IPX/AF	OK
3.2	shlf2IPX	IPX/AF	OK
3.3	shlf3IPX	IPX/AF	OK
4.1	shlf4IPX	IPX/AF	OK
4.3	shlf5IPX	IPX/AF	OK

Last Command: dspnode

Example of dspnode at node Shlf3IPX showing connection to “hubone”

```
shlf3IPX          TN    edgar          IPX 8    8.5    Nov. 20 1995 09:24 PDT
```

BPX Switching Shelf Information

Trunk	Name	Type	Alarm
8	hubone	BPX	MAJ

Last Command: dspnode

Next Command:

- Axis Shelf
 - At the BPX, add the AXIS as a shelf to the BPX (**addshelf**).
- Set up ATM service lines and ports.
 - Activate the line (**upln**).
 - Configure the line (**cnfln**).
 - Activate the ports (**upport**).
 - Configure the ports (**cnfport**)
- Set up ATM connections
 - Add connections (**addcon**).
 - Configure a connection type (**cnfcontyp**).
- Set up ATM to frame relay (ATF) connections
 - Add the connections (**addcon**).
 - Configure connection classes (**cnfcls**).
 - Configure connection groups (**addcongrp**).
- Setup Interface Shelf Frame Relay Connections in Tiered Networks
 - Refer to the SV+ Operations Manual
 - Only frame relay connections are supported from the IPX Interface Shelf and these are added and managed by the SV+ Connection Manager via the SNMP protocol. All connections are treated as end-to-end.
 - Frame relay connections terminated at an AXIS Shelf are added and managed by the SV+ Connection Manager via the SNMP protocol. All connections are treated as end-to-end.
 - ATM connections terminated at an AXIS IPX Shelf are added and managed using the Command Line Interface on the AXIS. All connections are treated as end-to-end.

Adding Virtual Trunks

This section details the steps for setting up a virtual trunk. Virtual trunking is an optional feature that must be enabled by StrataCom prior to adding virtual trunks. Also, revision levels of ASI and BNI firmware must be current. The following procedure assumes that StrataCom equipment is used in the ATM Cloud as well as in the StrataCom subnetworks. In this case, a BNI output from the subnetwork is connected to an ASI UNI input at the ATM Cloud (Figure 4-1). Proceed as follows:

- Step 1** In the ATM cloud network, physically connect an ASI port at the cloud edge to each BNI port in the StrataCom Network that is intended to have virtual trunks.

Figure 4-1 Virtual Trunks across a StrataCom ATM Cloud

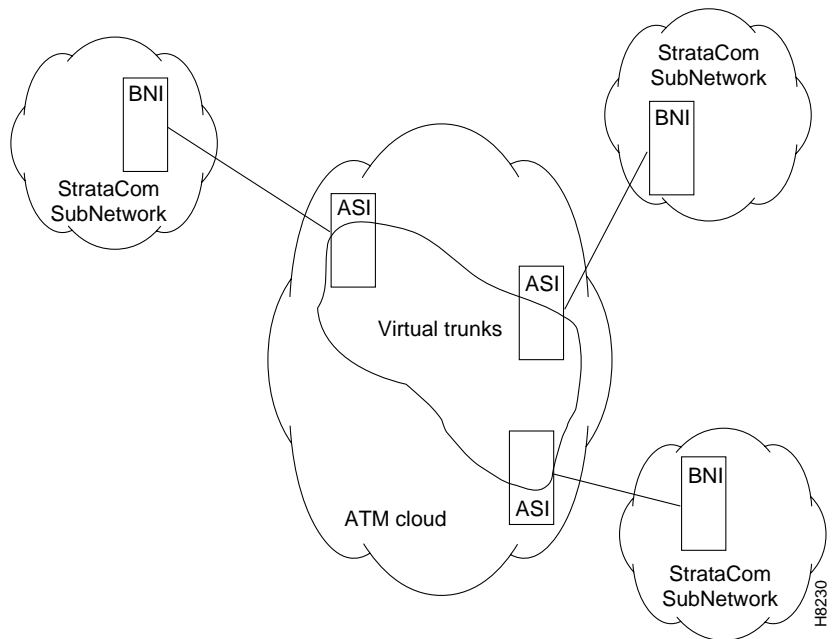

Step 2 Configure the cloud ASI ports. For each ASI port connected to a BNI virtual trunk port, do the following:

upln <slot.port>

upport <slot.port>

cnfport <slot.port> and set the *shift* parameter to “N” for no shift if the cloud contains BPX nodes.

Step 3 Execute **addcon**. In the cloud network, add a virtual path ASI connection for each virtual trunk that is to route through the cloud. An example of this syntax for this is:

addcon joker 5.1.1.* swstorm 6.2.10.*

where 5.1 and 6.2 are ASI ports hooked up and configured for virtual trunking. Daxcons are acceptable.

Note that the third number is the VPI which must correspond to the virtual trunk VPI configured with **cnftrk** in step 4.

When the cloud is a public ATM service and not a StrataCom cloud, the VPI is provided by the carrier, as well as the guaranteed BW associated with the VPI.

The CBR/VBR/ABR parameters must also correspond to the Virtual Trunk Type of the virtual trunk. For T3, set PCR to the bandwidth of the virtual trunk, and CDVT to 24000 for the connection so that the ASI does not drop cells. These are values that StrataCom recommends based on testing.

Step 4 Configure BNI virtual trunks. On the BNIs that connect to the cloud ASI ports, configure up to 32 virtual trunks, as follows:

uptrk <slot.port.vtrk>

cnftrk <slot.port.vtrk>

For **cnftrk**, make sure that the virtual trunk type and the VPI correspond to the ASI Virtual Path connections that have been set up.

addtrk <slot.port.vtrk>

For further information, refer to the *Command Reference* document.

BPX Management

You can monitor, manage and troubleshoot the BPX using the StrataView Plus Network Management Station. Commands are issued to a BPX node through the Node Administration window. Frame Relay connections are added via the StrataView Plus Connection Manager. You can display and monitor the network's topology, monitor alarms, events, and statistics. Refer to the StrataView Plus Operations Guide for more information.

For detailed configuration information, refer to the *Command Reference* document.

IP Setup and IP Relay Configuration (Preliminary)

In setting up network management for a network, both the SV+ workstation and network nodes need to be configured. SV+ communicates over a standard physical LAN network to a gateway node or nodes, but a separate in-band IP relay network is setup for all nodes via a gateway node for SNMP and TFTP in-band communication over the node trunks (Figure 4-2).

Figure 4-2 SV+ Physical LAN and IP Relay Network

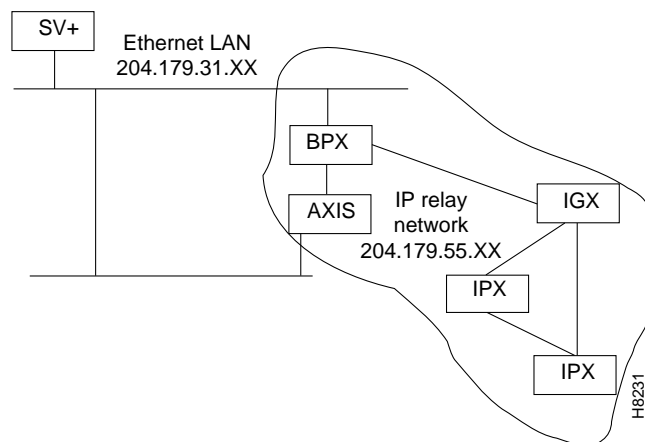

Installing SV+ and Associated Applications

Refer to the *StrataView Plus Overview*, the *Command Reference*, and the *AXIS Reference* documents for additional information.

Configure SV+ Workstation (example)

- Step 1** Enter physical IP addresses and physical LAN node names (with a letter "p", for example to differentiate from IP relay name) in `/etc/hosts` and enter IP relay addresses and actual node names.

```
beacon% more /etc/hosts
#
# Sun Host Database
#
# If the NIS is running, this file is only consulted when booting
#
127.0.0.1      localhost
#
204.179.61.121 beacon loghost

# node physical ethernet LAN addresses

204.179.61.104 nw1bpx1p
204.179.61.71  nw1axi1p

# node ip relay addresses

204.179.55.101 nw1ipx1
204.179.55.102 nw1ipx2
204.179.55.103 nw1ipx3
204.179.55.123 nw1igx1
204.179.55.111 nw1bpx1
204.179.55.105 nw1axi1
```

If the workstation is connected to the corporate network, add any IP addresses and associated names of hosts that you may want to connect to your workstation, as the NIS is disabled.

- Step 2** Enter name of gateway node in config.sv, using physical LAN name.g., nw1bpx1p. Note; normally, a bpx is used for the gateway node because of its greater processing power.

```
0|Network1|nw1bpx1p|9600|0|7|6|0|30|1024|8.1|
```

- Step 3** Enter IP Relay subnet mask at end of rc.local file:

```
# route add for SV+
```

```
route add net 204.179.55.0 nw1ipx1p 1
```

Note The route add command is for all nodes in the 204.179.55.0 subnetwork. The name “nw1bpx1p” is the name associated with the physical LAN port on the gateway node, e.g., nw1bpx1

- Step 4** Contact Corporate Network Administrator, but in order for workstation to use /etc/hosts, it must not be able to access the NIS directory. A work around is to perform the following:

```
mv /etc/defaultdomain /etc/defaultdomain_old
```

Network Node Configuration (Preliminary)

Adding nodes, adding trunks, shelves, etc.

Refer to the applicable Reference manuals, IPX, BPX, IGX, AXIS, etc., for node installation and operation.

As a minimum, the nodes need to be configured with name (cnfname), date (cnfdate), time (cnftime), timezone (cnftmzn), and trunks upped (uptrk) and added (uptrk or addshelf, as applicable). Connections can also be added now, or added later, after configuring the nodes for operation with the SV+ NMS manager.

Configuring the IPX, IGX, and BPX for SV+ NMS Operation

On IPX, BPX, IGX nodes the following commands are used to configure the nodes for operation with SV+: **cnflan**, **cnfnwip**, **cnfstatmast**, **cnfsnmp**. The AXIS is configured with **cnfifip** and **cnfstasmgr**. The cnflan command is only necessary for nodes or shelves in which the LAN port is actually connected to a physical Ethernet LAN.

Configuring the AXIS for SV+ NMS Operation (example)

At installation, initial access to the AXIS is provided by the control port.

Step 1 Connect a terminal to the control port on the AXIS workstation.

Step 2 Login

```
login: "LoginID"

password:
card number: 3

xxxxAXIS.1.3.ASC.a >
```

Step 3 Name the shelf

```
xxxxAXIS.1.3.ASC.a > cnfname nwlaxil
```

Step 4 Set the date:

```
nwlaxil.1.3.ASC.a > cnfdate 05/02/96
```

Step 5 Set the time:

```
nwlaxil.1.3.ASC.a > cnftime 15:31:00
```

Step 6 Enter Help for a list of commands:

```
nwlaxil.1.3.ASC.a > Help
```

Step 7 Check versions of ASC, and Service Module (e.g., FRSM, AUSM) Firmware

```
nwlaxil.1.3.ASC.a > version
***** Stratacom Inc. AXIS ASC Card *****2
Firmware Version      = 2.1.12b_____
Backup Boot version   = model-B BT_2.0.0_____
ASCFRSM Xilinx file   = asc025.h
ASCBNM Xilinx file    = bnmt3andsrefix
VxWorks (for STRATACOM) version 5.1.1-R3000.
Kernel: WIND version 2.4.
Made on Thu May 2 16:42:36 PDT 1996.
Boot line:
sl(0,0)

cc
```

Step 8 Enter Ethernet LAN port IP address

```
nwlaxil.1.3.ASC.a > cnfifip
cnfifip "-ip <ip addr> -if <Interface> -msk <NetMask> -bc <Brocast addr>
```

Network Node Configuration (Preliminary)

```
"  
-ip <IP addr> where IP addr = nnn.nnn.nnn.nnn  
-if <Interface> where Interface = 26,28,37, 26: Ethernet, 28: Slip 37: ATM  
-msk <NetMask> where NetMask = nnn.nnn.nnn.nnn  
-bc <BrocastAddr> where BrocastAddr = nnnnnnnn, n is hexadecimal, ethernet only
```

```
nwlaxil.1.1.3.ASC.a > cnfifip -ip 204.179.61.71 -if 26
```

You are configuring ethernet port are you sure? enter yes/no: yes

Step 9 Enter IP Relay Address for SNMP Management and Stats Collection

```
nwlaxil.1.1.3.ASC.a > cnfifip -ip 204.179.55.105 -if 37
```

You are configuring atm port are you sure? enter yes/no: yes

Step 10 Configure stat master address (IP of SV+ workstation)

```
cnfstatsmgr "<ip address>"
```

```
nwlaxil.1.1.3.ASC.a > cnfstatsmgr 204.179.61.121 {this is IP address of SV+ workstn}
```

Repair and Replacement

This chapter describes periodic maintenance procedures, troubleshooting procedures, and the replacement of major BPX components.

The chapter contains the following:

- Preventive Maintenance
- Troubleshooting the BPX
- Replacing Parts

Preventive Maintenance

Most monitoring and maintenance of the BPX is done via the BPX operating system software. Preventive maintenance of the BPX hardware is minimal and requires only the following:

- 1 Periodically check the node supply voltage and internal cabinet temperature with the **dspasm** command. It should not exceed 50 °C.
- 2 Periodically check the event log with the **dsplog** command.
- 3 Periodically check the network alarm status with the **dspalms** command.

Troubleshooting the BPX

This section describes basic troubleshooting steps to be taken for some of the more obvious node failures (refer to Table). This is not an exhaustive set of procedures, and does not take into account any of the diagnostic or network tools available to troubleshoot the BPX. Refer to the “Troubleshooting Commands” chapter in the *Command Reference Manual* for information on commands and command usage.



Caution Do not perform any disruptive tests or repairs to the BPX on your own. Before proceeding with troubleshooting, call Customer Service so they can provide you with assistance in locating the fault and provide repair information.

General Troubleshooting Procedures

The BPX runs self tests continuously to ensure proper function. When the node finds an error condition that affects its operation, it downs the card or trunk affected. It then selects a standby card or alternate trunk if one is available.

The FAIL indicators on the cards indicate that the system has found these cards defective in some mode, and now considers them as failed cards. It is at this point that you would use Table to find the cause and obtain the information on replacing the failed component.



Caution When using Table 5-1 for troubleshooting, call Customer Service before performing any disruptive testing, or attempting to repair the BPX. This ensures that you have isolated the correct problem area. It also enables Customer Service personnel to provide assistance in performing the necessary procedures.



Warning Contact Customer Service before attempting to replace fuses on backplane, and refer to instructions in Replacing Card Slot and Fan Fuses on the System Backplane.

Table 5-1 Troubleshooting the BPX Node

Symptom	Probable Cause	Remedy
Front panel LED on individual card not lighted	Card Fuse	Check card fuse. Replace if defective. Try another card of the same type. If still no LED lighted, backplane card slot fuse may be defective. Refer to Replacing Card Slot and Fan Fuses on the System Backplane.
No front panel LEDs are lighted.	AC Systems: <ul style="list-style-type: none"> • Circuit Breakers on AC Power Supply Tray DC Systems: <ul style="list-style-type: none"> • Circuit breakers on Power Entry Module(s) switched off. 	Switch on circuit breakers. If problem persists, pull all cards and power supplies out to see if a shorted card or supply exists.
Power supply ac LED lit but dc LED not lit.	BPX power cord plug dislodged from AC receptacle.	Check that no one is working on system, shut off source breaker, then reconnect power cord.
Power supply ac LED lit but dc LED not lit.	Power supply defective.	Check DC ok LEDs on ASM. If out, remove and replace power supply. If on, PS LED probably defective.
Card front panel fail LED lit	Card failed self-test.	Check status of card at NMS terminal using dspcds screen. If alarm confirmed, try card reset (resetcd command). Finally, remove and replace the card.
Card stby LED on.	Card is off-line.	Not a problem as long as primary card is active.
ASM major or minor LED on.	Service-affecting (major) or non-service affecting (minor) system fault.	Check NMS event log to identify problem reported.
	Failed card in local node.	See remedy for card fail LED indication.
	Network trunk failed.	Observe Port LEDs on each BNI or BXM (ports configured in trunk mode). Use NMS dsptrk to locate failure.
	Failure in remote node. May be another BPX or an IPX.	Use NMS dspnw screen to locate node in alarm. Refer to Troubleshooting Commands in the <i>Command Reference</i> for additional information.

Table 5-1 Troubleshooting the BPX Node (Continued)

Symptom	Probable Cause	Remedy
	Internal temperature is higher than normal resulting from blocked air flow or defective fan.	Check front and back of node cabinet for freedom of air flow. Replace any fan that may have failed or slowed. Use NMS dsppwr screen to check node temperature.
ASM hist LED lit.	If no other alarm indications, a fault occurred in the past but has been cleared.	Press ASM history clear button. Check NMS event log to determine cause.
BXM Port LED is red or orange (BXM configured for trunk mode).	Trunk is in local or remote alarm.	Use NMS dsprtk screen to confirm trouble.
BNI Port LED is red or orange .	Trunk is in local or remote alarm.	Use NMS dsprtk screen to confirm trouble. Use short BNC loopback cable at LM-BNI connectors for local test of trunk. Loop trunk at DSX-3 crossconnect to check cable.
No BXM card or port LED on.	No trunks or lines, as applicable on card are upped. Card not necessarily failed.	Up at least one of the trunks or lines, as applicable, associated with the card (Trunks if BXM configured for trunk mode, lines if BXM configured for port mode).
No BNI card or port LED on.	No trunks on card are upped. Card not necessarily failed.	Up at least one of the trunks associated with the card.
BXM Port LED is red or orange (BXM configured for port mode)	Line is in local or remote alarm.	Use NMS dsplns screen to confirm trouble.
ASI Port LED is red or orange.	Line is in local or remote alarm.	Use NMS dsplns screen to confirm trouble.
No ASI card or port LED on.	No lines on card are upped. Card not necessarily failed.	Up at least one of the two lines associated with the card.
BCC fail LED flashing	Downloading system software or configuration data.	Wait for download to complete.
BCC LAN LED flashing	Normal for node connected to NMS terminal over Ethernet. If it does not flash, there may be problems with node to NMS data path.	Check that the cabling to the NMS is firmly connected to the LAN port on the LM-BCC back card. An alternate connection is to the control port.
No BCC card LED on.	Preparing to download new software (momentary condition).	Wait for download to begin.
	Command issued to run a software rev. that was not available in the network.	Check that proper s/w rev. is available on another node or on NMS.

Displaying the Status of Cards in the Node

When a card indicates a failed condition on the alarm summary screen, use the Display Cards (**dspcds**) command to display the status of the circuit cards on a node. The information displayed for each card type includes the card slot number, software revision level, and the status of the card. The possible status description for each card type are listed in Table 5-2. Refer to the *Command Reference* for more information on the Display Cards command.

Table 5-2 Card Status for the BPX

Card Type	Status ¹	Description
All card types	Active	Active card.
	Active - F	Active card with no terminal failure.
	Standby	Standby card.
	Standby - F	Standby card with no terminal failure.
	Standby - T	Standby card performing diagnostics.
	Standby - F -T	Standby card with no terminal failure performing diagnostics.
	Failed	Card with terminal failure.
	Unavailable	Card is present but it may be in one of the following states: a. The node does not recognize the card. b. The card is running diagnostics.
	Down	Downed card.
Empty	No card in that slot.	
BCC	Same status as for all card types, plus:	
	Updating	Standby BCC downloading the network configuration from an active BCC. Note: Red FAIL LED flashes during updating.
	Cleared	BCC is preparing to become active.
	Downloading Software	There are downloader commands that appear when the system is down- loading software to the BCC.
Minor	BCC Redundancy alarm indicates node is configured for redundancy but no standby BCC is equipped.	

1. Cards with an F status (no terminal failure) are activated only when necessary. Cards with a failed status are never activated.

Replacing Parts

After an alarm occurs, use the BPX software to isolate the problem. (Refer to Troubleshooting the BPX for troubleshooting information). If an BPX part has failed, then it must be replaced.



Caution Only authorized personnel should remove and replace parts on the BPX system.

Parts should be replaced only by qualified personnel who have taken the StrataCom training courses or have been trained by a qualified system manager. For assistance in diagnosing or replacing a failed part, call the Customer Service representative.

When replacing a part, save the electrostatic bag, foam, and carton that the new part comes in. These packaging materials are needed for returning the failed part to Cisco. Contact Customer Service for information on returning parts.

Replacing a Front Card

The BPX front cards are as follows:

- Broadband Controller Card (BCC).
- BXM-T3/E3, BXM-155, BXM-622
- Broadband Network Interface Card (BNI).
- Alarm and Status Monitor (ASM).
- Access Service Interface (ASI-1)



Caution Ground yourself before handling BPX cards by placing a wrist strap on your wrist and clipping the wrist strap lead to the cabinet.

When a card has failed, the red FAIL indicator for that card turns on. Before replacing it, check to see if the card only needs to be reseated. After reseating the card, wait for it to run its self-tests to see if the ACTIVE light comes on. If the card is seated correctly, but the FAIL light is still on, replace the card.

To remove a front card, perform the following steps:

- Step 1** If the front panel **fail** lamp is on, remove the card and go to Step 3. Otherwise, go to Step 2.
- Step 2** Check the status of the card using the **dspcd** or **dspcds** commands. It should be failed or standby if the node is actively carrying traffic.
- Step 3** If an active card (ASI, BNI) needs to be replaced, “down” it first with the **dncd** command. Removing an active card affects operation only slightly if there is a standby card.
- Step 4** If a BCC has failed, the other BCC will switch from standby mode to active. Use the **dspcd** command to verify that the standby BCC has entered the active mode. Then you can remove the failed BCC.



Caution Never remove the active BCC until the standby BCC has entered the “active” mode. Using the `dspcd` command is the only reliable way to determine that the standby BCC has finished updating and has entered the “active” mode.

Step 5 Unlatch the Air Intake Grille. Locate the small access hole in the top, center of the Air Intake Grille.

Step 6 Fully insert a medium, flat-bladed screwdriver in the access hole.

Step 7 Rotate the screwdriver to release the spring latch holding the grille. (Figure 5-1). The top of the grille should pop out.

Step 8 Tilt the grille forward to approximately a 45° angle.

Step 9 Put on a wrist strap to discharge any static.

Step 10 Rotate the top and bottom card extractors on the front of the card.

Step 11 Hold the card at the top and bottom and gently slide it out of the slot.

To install a front card in the BPX, perform the following steps:

Step 1 Unlatch the Air Intake Grille as described in Step 5 through Step 8 of the previous procedure for removing the front card.

Step 2 Remove the replacement card from the antistatic shipping container.

Step 3 Hold the replacement card at top and bottom and gently insert it over the guides, and slide it all the way to the rear of the cabinet.

Note The card should slide in easily with a light sliding friction from the EMI gaskets on adjacent cards. If it does not, check to see if there is anything restricting it—do not use excessive force.

Step 4 Rotate the top and bottom latches on the card and push the card into the rear connector. You will feel the card seat itself as you push it in.

Step 5 Press firmly on the top and bottom extractors to complete the card seating process. The extractor should snap back to a vertical position after the card is properly seated.

Step 6 Replace the air intake grille by swinging it up and pressing in at the top until the latch snaps into place.

Figure 5-1 Unlatching the Air Intake Grille

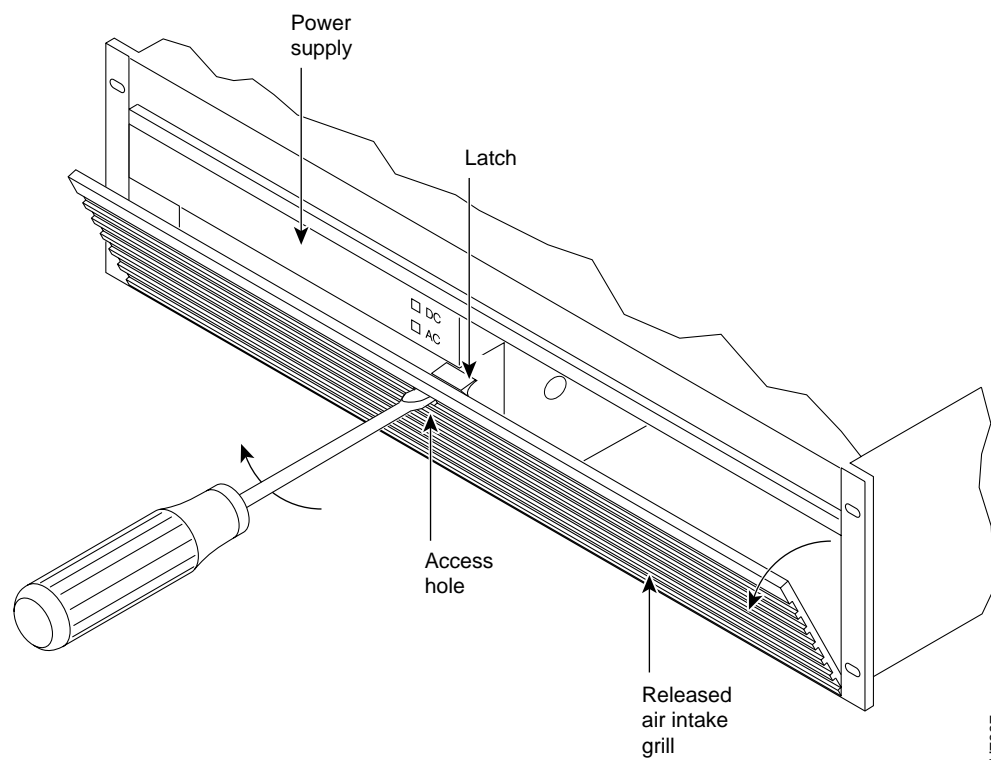

Replacing a Line Module

The configuration of the back card may be slightly different depending on whether it is a single card or redundant card configuration. A standby card in a redundant card configuration may be removed without disrupting system operation even if it is a BCC. Removing a single card, however, will cause a system outage.



Caution Removing an active, single back card disrupts service on the node.

To remove a line module, perform the following steps:

- Step 1** Check the status of the card using the **dspscd** or **dspscds** command. It should be failed or standby or replacement will affect operation of the node.
- Step 2** If an active card needs to be replaced, “down” it first with the **dned** command. Removing an active card affects operation only slightly if there is a standby card.
- Step 3** Before removing a LM-BCC, make sure the standby BCC **stby** indicator is on steady. A flashing **stby** indicator indicates it is in the process of downloading either configuration data or software and is not ready to accept a transfer.
- Step 4** For a single card configuration, disconnect the cables from the back card face plate. Make a note of the location of each cable so that it can be replaced correctly.
- Step 5** For a redundant card configuration, disconnect the appropriate leg of the Y-cable connecting to the back card to be replaced. **DO NOT REMOVE THE OTHER LEG GOING TO THE BACKUP CARD.**

- Step 6** Loosen the two captive screws on the back card faceplate and, pulling on the top and bottom card extractors, slide the card straight out of the shelf slot. See Figure 5-2.

To install a line module, perform the following steps:

- Step 1** Insert the line module (e.g., LM-3T3) into the slot from which the defective card was removed (see Figure 5-2).
- Step 2** Tighten the two captive screws (Tighten securely, but do not overtighten.)
- Step 3** Reconnect the T3 trunk cables to the LM-3T3 connectors from which they were disconnected.
- Step 4** Perform the appropriate steps to bring the lines that were disconnected back on line.

Figure 5-2 Removing a Line Module

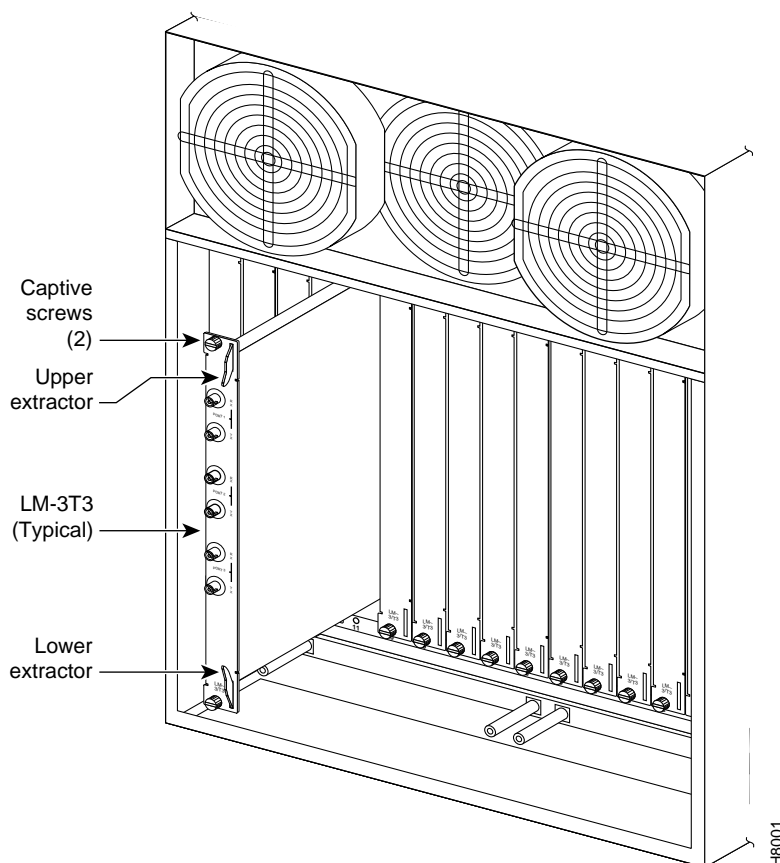

Replacing a DC Power Entry Module

DC Power Entry Modules (PEMs) contain few active components so they should rarely need replacement. Access is from the back of the node. To remove a PEM, proceed as follows:

- Step 1** If you haven't already done so, check the node system voltage by using the Display Power (**dsppwr**) command. Note which input has failed, A or B. Power Supply A is the unit on the right side facing the rear of the node.
- Step 2** Turn off the primary source of power to the PEM to be replaced.
- Step 3** Turn off the circuit breaker on the PEM to be replaced.
- Step 4** Remove the two screws holding the conduit box cover (Figure 5-3). Or, remove the plastic cover plate over the input terminal block.
- Step 5** Remove the power input wiring at the PEM terminal block.

Figure 5-3 DC Power Entry Module with Conduit Box

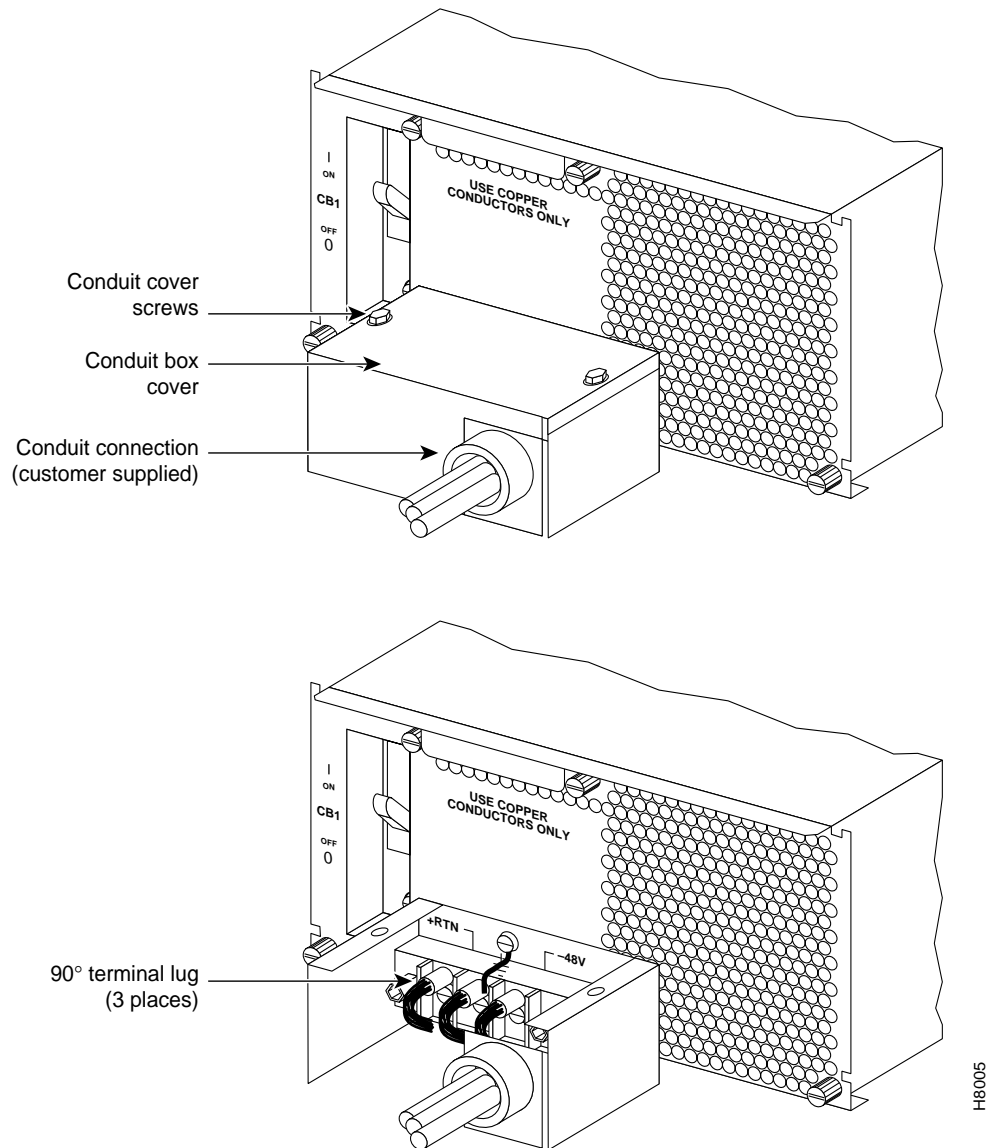

- Step 6** If a conduit box is used, remove it. Remove the ground screw above the middle terminal block connector (Figure 5-3).
- Step 7** Remove the two standoffs on each side of the terminal block, and pull the conduit box straight back. Set it aside. Do not try to remove the terminal block.
- Step 8** Loosen the two captive screws (at the bottom corners) holding the PEM. Loosen the two connector jackscrews adjacent to the finger pull.
- Step 9** Grasp the finger pull lip at the top of the PEM and pull the unit straight out.
- Step 10** Replacement is the reverse of removal.

Replacing an AC Power Supply

BPX nodes are powered by redundant power supplies; either power supply can supply the current requirements of the node. The AC Power Supply is part of an assembly which is replaced as a single unit. Access to the AC Power Supply assembly is from the front, but first, the Air Intake Grille must be removed.

To remove a power supply, proceed as follows:

- Step 1** If you haven't already done so, check the status and output voltage of the power supplies at the node using the `dspasm` command. Note which power supply is failed, A or B. Power supply A is on the right side facing the rear of the node.
- Step 2** Remove the Air Intake Grille. Locate the small access hole in the top, center of the Air Intake Grille.
- Step 3** Fully insert a flat-bladed screwdriver (with a 1/4 in. blade) in the access hole.
- Step 4** Rotate the screwdriver to release the spring latch holding the Air Intake Grille (Figure 5-4). The grille should pop out.

Figure 5-4 AC Power Supply Assembly

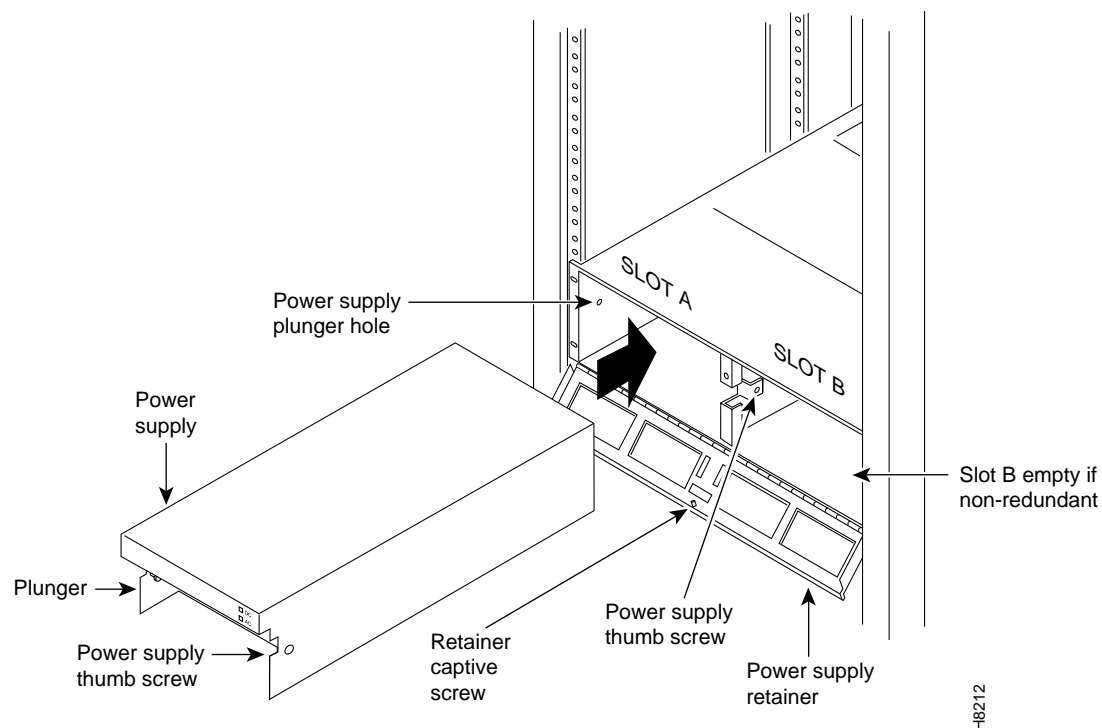

- Step 5** Tilt the grille forward approximately a 45° angle, then lift it out and set it aside. This exposes the power supply retainer bracket.
- Step 6** With a flat-bladed screwdriver, loosen the retainer bracket hold-down screw in the center of the bracket and tilt the bracket.
- Step 7** Identify which power supply needs replacement. Power supply A is the unit on the left, B is on the right. In most cases, the failed unit will be identified by a front panel lamp indication.

- Step 8** There are two power supply securing fasteners, one on each side of the power supply assembly (Figure 5-4). The one on the left of each supply is a spring-loaded pin, the one on the right of each supply is a normal thumb-screw. Loosen the thumb-screw on the right.
- Step 9** With the right hand, grip the power supply under the front panel. With the left hand, pull out the spring-loaded pin on the left side of the supply and hold it out as you pull out the power supply assembly.
- Step 10** The power supply assembly weighs approximately 15 pounds (33 Kgs.). Get ready to support the bottom of the power supply with your free hand as you continue to pull it straight out, until it is free of the shelf.

Field-Installing a Second AC Power Supply

To field-install a redundant power supply, perform the following steps:

- Step 1** If the front Air Intake Grille has already been removed, go to the next step. If not, remove it using Step 2 through Step 6 of the previous procedure (refer to Replacing an AC Power Supply section).
- Step 2** If converting a node from single to redundant powering, first remove the blank filler panel over position B (right side). With Air Intake Grille open, remove three screws attaching the filler panel to the retainer bracket (see Figure 5-5).

Figure 5-5 Removing Blank Filler Panel (B side shown)

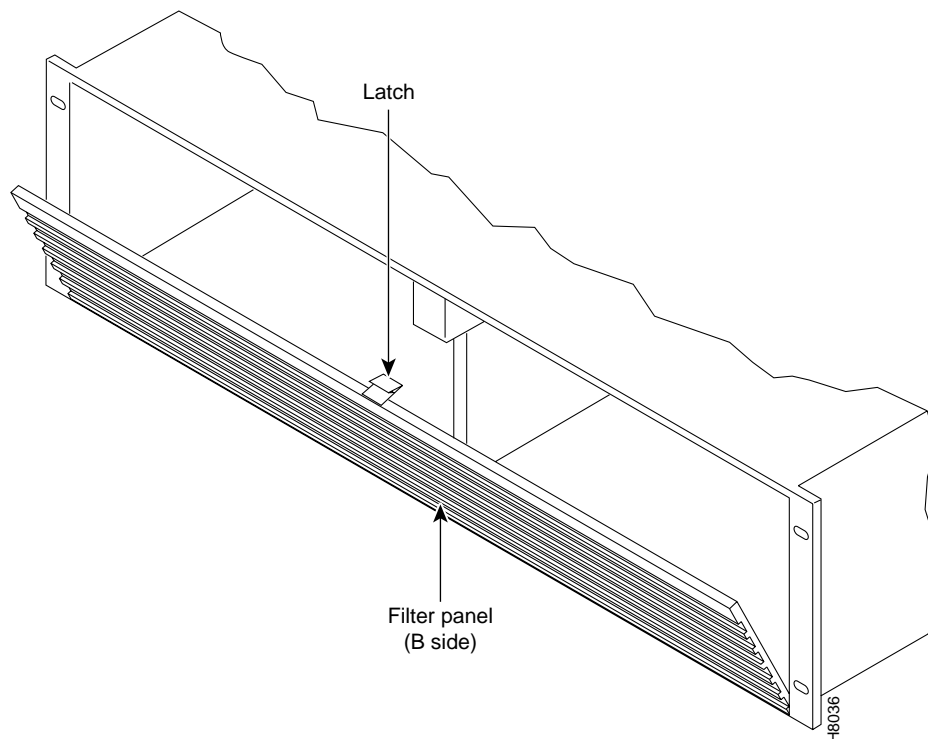

- Step 3** Slide a replacement power supply assembly into the tracks of the power supply shelf.
- Step 4** When the power supply is completely seated, the spring-loaded pin will snap into place to assure that the power supply has mated with its connector.
- Step 5** Screw in the thumb-screw on the right side of the power supply assembly until it is finger tight.
- Step 6** Flip the retaining bracket up and tighten its thumbscrew.
- Step 7** Reinstall the Air Intake Grille and press firmly on the top, center of the Air Intake Grille until the latch snaps into place.
- Step 8** Check the status and output voltage of the replacement power supply using the **dspsm** command. Make sure the status is OK and the output voltage is 48V.

Replacing the Fan Assembly

The Fan Assembly provides the primary cooling for the BPX node and is located at the top, rear of the BPX cabinet. There are three fans in the Fan Assembly. The fan on the right (#1) and the one on the left (#3) can be changed out individually with very little effort or interruption in the operation of the node. The fan in the middle (#2) requires powering down the node and removing the Fan Assembly to replace.



Caution You must work quickly to prevent heat buildup in the node which could damage the cards.

To replace fan #1 or #3 in the Fan Assembly, perform the following steps:

- Step 1** Use the **dspasm** command to check the status of the three fans.
- Step 2** From the rear of the BPX cabinet, visually check that the fan(s) is indeed not turning or turning slowly.
- Step 3** From the back of the cabinet, unplug the small fan power cord from its appropriate receptacle on the Fan Assembly.
- Step 4** Remove the two screws holding the fan and the fan shield to the-fan housing. Be careful not to drop the hardware into the rear of the cabinet.
- Step 5** Remove the fan. Replace the fan in reverse order. Use the existing fan grille.

To replace fan #2 requires powering down the node and replacing the whole Fan Assembly. Under normal ambient room temperatures, this can be scheduled for the next available quiet time. Perform the following steps:

- Step 1** Use the **dspasm** command to check the status of the three fans.
- Step 2** From the rear of the BPX cabinet, visually check that the fan #2 is indeed not turning or turning slowly.
- Step 3** At the rear of the BPX cabinet, turn the circuit breaker(s) OFF to power down the node.
- Step 4** Loosen the eight captive screws holding the Fan Assembly in place.
- Step 5** With one hand, pull the Fan Assembly back just far enough to gain access to the Fan Assembly power cord. This cord connects to the Fan Assembly to the backplane.
- Step 6** Unplug the power cord and remove the Fan Assembly.
- Step 7** Plug the power cord in the replacement Fan Assembly into the backplane connector.
- Step 8** Install the replacement Fan Assembly.
- Step 9** Tighten the eight screws holding the Fan Assembly in place.

Replacing the Temperature Sensing Unit

The temperature sensing unit is located on the ASM card. If the temperature indication using the **dspasm** command does not appear to be correct, try a replacement ASM card.

Replacing Card Slot and Fan Fuses on the System Backplane

There is a separate fuse provided on the System Backplane for each card slot. These fuses are numbered F4 through F18, corresponding to card slots F15 down through F1 respectively (Figure 5-6). There three separate fan fuses provided on the System Backplane. These fuses are numbered F1 through F3, corresponding to Fans 1 through 3 (Figure 5-6).



Warning For both personnel safety and to prevent equipment damage, power down the BPX node before replacing, fan fuses F1 through F3, or card slot fuses F4 through F18 on the System Backplane. For continued protection against risk of fire, replace only with same type and rating of fuse.

Backplane fuses rarely, if ever, need replacement. Backplane fuses are intended to prevent catastrophic damage to the backplane in the event of accidental shorting of -48VDC on the backplane to chassis ground. This type of event could be caused by bent backplane pins, inadvertent contact of conductive elements (EMI Cans, EMI Gaskets, etc.) to power pins, or (in the case of a fan fuse) a pinched wire harness.

These fuses are located in sockets on the backplane and are therefore not readily accessible. A special tool (StrataCom P/N 218090-00) and a special set of instructions are required for fuse replacement. It is recommended that only factory-trained personnel perform the procedure. Contact Customer Service for further information.

Figure 5-6 Card Slot and Fan Fuse Locations on System Backplane

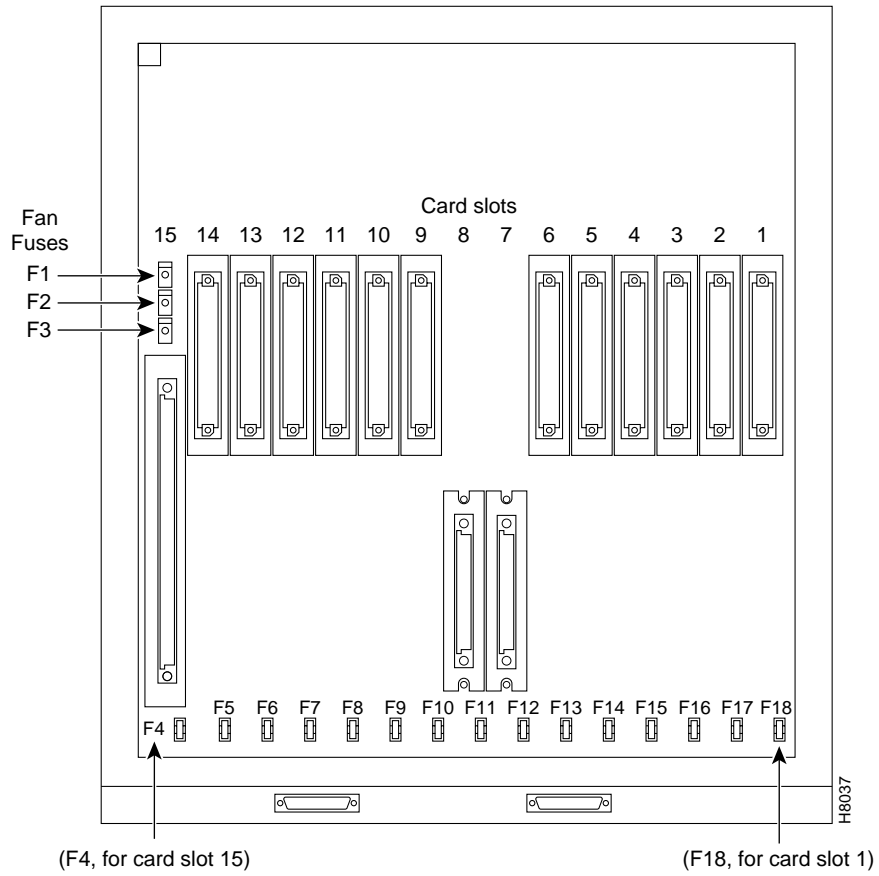

Frame Relay to ATM Network and Service Interworking

This chapter describes Frame Relay to ATM interworking. Frame Relay to ATM Interworking allows users to retain their existing Frame Relay services, and as their needs expand, migrate to the higher bandwidth capabilities provided by BPX ATM networks.

This chapter contains the following:

- Service Interworking
- Networking Interworking
- ATM Protocol Stack
- AIT/BTM Interworking and the ATM Protocol Stack
- AIT/BTM Control Mapping, Frames and Cells
- Management, OAM Cells
- Functional Description
- Management

Frame Relay to ATM Interworking enables frame relay traffic to be connected across high-speed ATM trunks using ATM standard Network and Service Interworking (Figure 6-1 and Figure 6-2).

Two types of Frame Relay to ATM interworking are supported, Network Interworking and Service Interworking. The Network Interworking function is performed by the AIT card on the IPX and by the BTM card on the IGX. The FRSM card on the AXIS supports both Network and Service Interworking. See Figure 6-3 for some examples of ATM to Frame Relay Interworking.

Figure 6-1 Frame Relay to ATM Network Interworking

Part A

Network interworking connection from CPE Frame Relay port to CPE Frame Relay port across an ATM Network with the interworking function performed by both ends of the network.

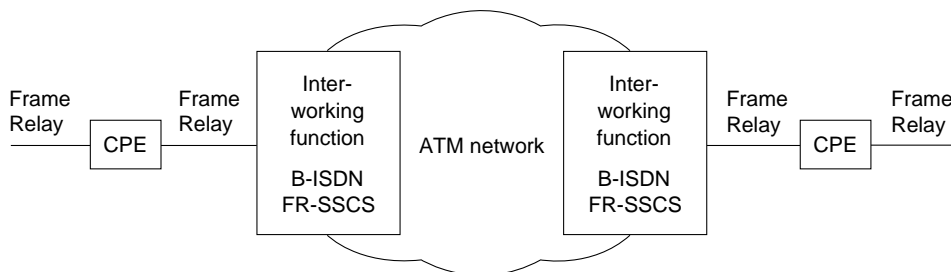

Part B

Network interworking connection from CPE Frame Relay port to CPE ATM port across an ATM network, where the network performs an interworking function only at the Frame Relay end of the network. The CPE receiving and transmitting ATM cells at its ATM port is responsible for exercising the applicable service specific convergence sublayer, in this case, (FR-SSCS).

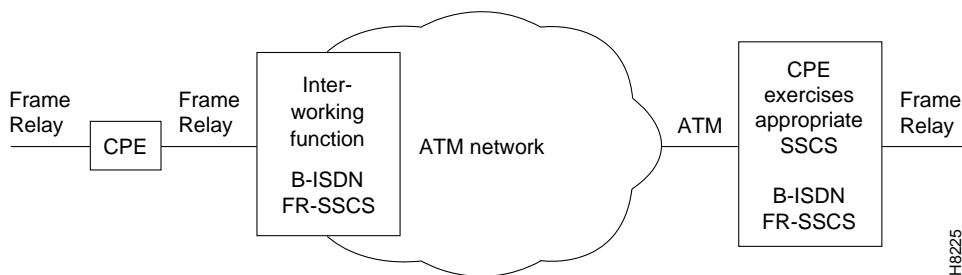

Figure 6-2 Frame Relay to ATM Service Interworking

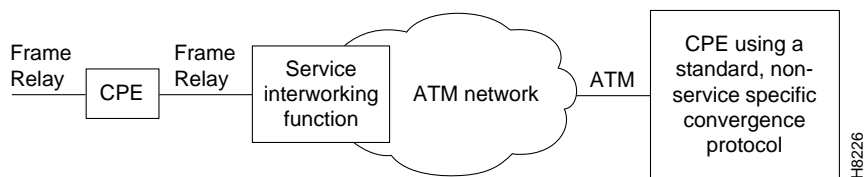
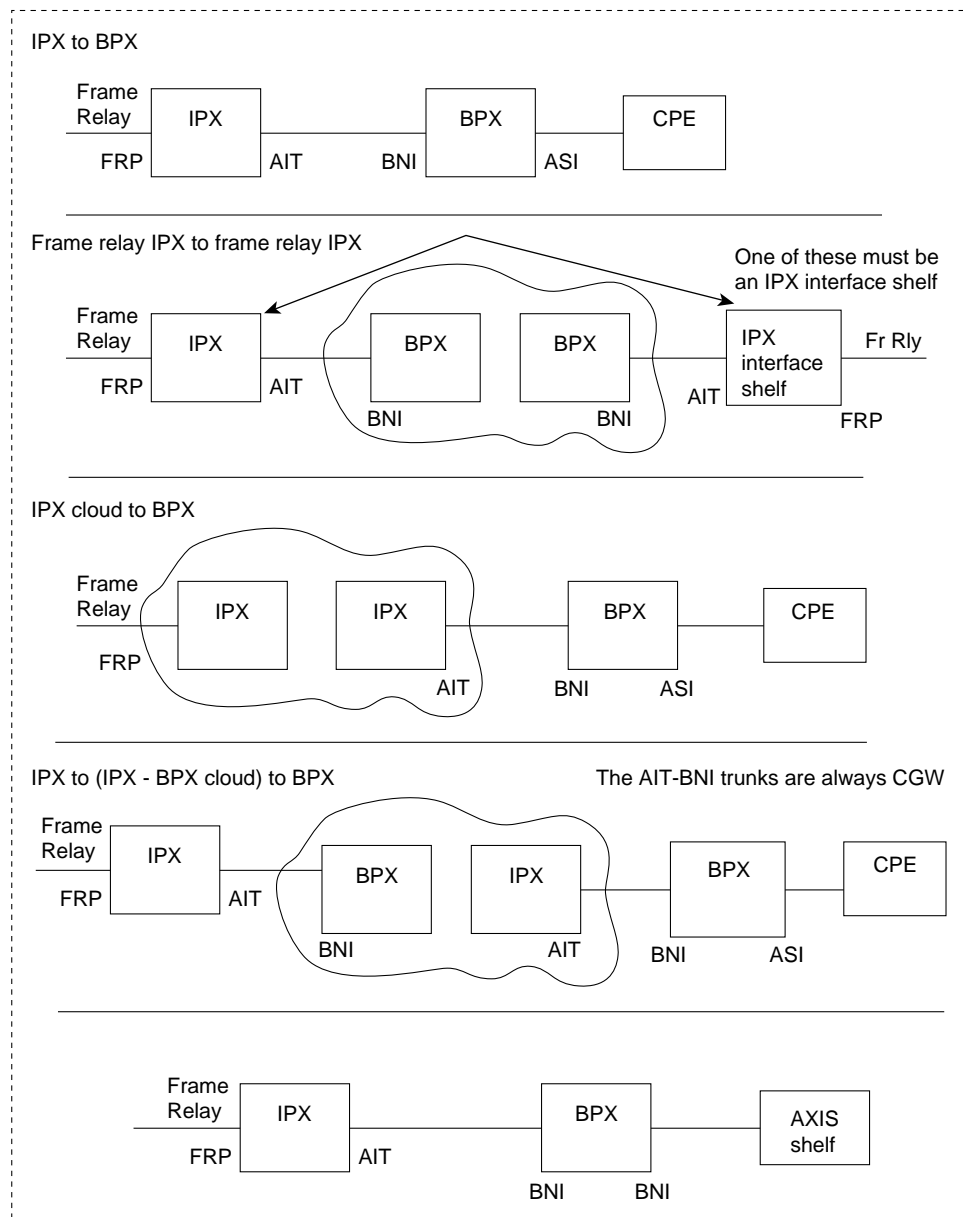

Figure 6-3 Frame Relay to ATM Interworking Examples with AIT Card on IPX



S5239

AIT Interworking Examples

Service Interworking

In Service Interworking, for example, for a connection between an ATM port and a frame relay port, unlike Network Interworking, the ATM device does not need to be aware that it is connected to an interworking function. The ATM device uses a standard service specific convergence sublayer, instead of using the Frame Relay FR-SSCS (Figure 6-4).

The frame relay service user does not implement any ATM specific procedures, and the ATM service user does not need to provide any frame relay specific functions. All translational (mapping functions) are performed by the intermediate IWF. The ATM endpoints may be any ATM UNI/NNI interface supported by the AXIS shelf, e.g., ASI, AUSM. Translation between the Frame Relay and ATM protocols is performed in accordance with RFC 1490 and RFC 1483.

Figure 6-4 Frame Relay to ATM Service Interworking Detail

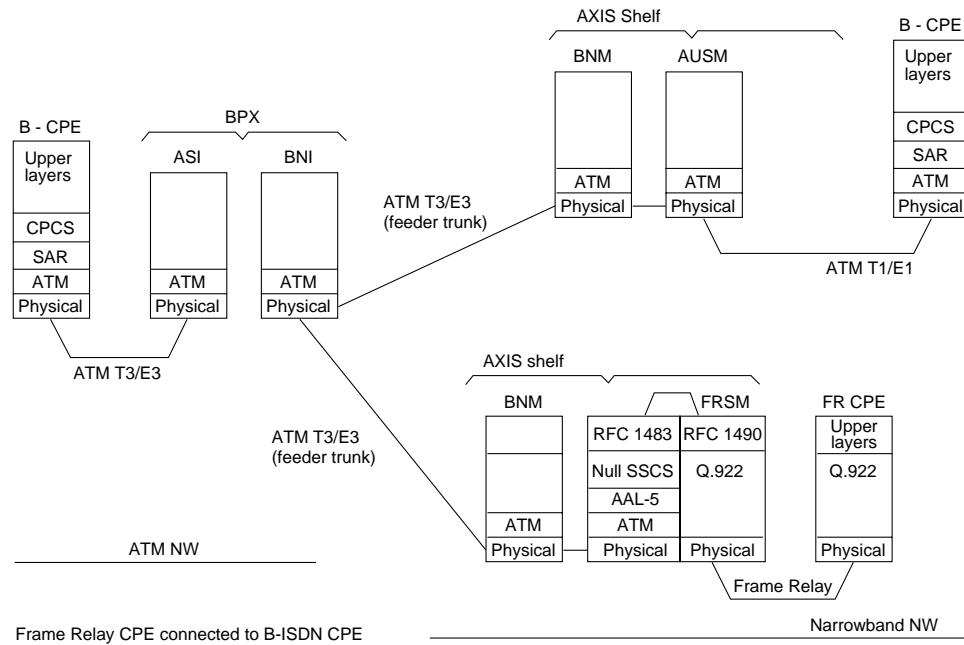

Networking Interworking

In Network Interworking, in most cases, the source and destination ports are frame relay ports, and the interworking function is performed at both ends of the connection as shown in Part A of Figure 6-5.

If a frame relay port is connected across an ATM network to an ATM device, network interworking requires that the ATM device recognize that it is connected to an interworking function (frame relay, in this case). The ATM device must then exercise the appropriate service specific convergence sublayer (SSCS), in this case the frame relay service specific convergence sublayer (FR-SSCS) as shown in Part B of Figure 6-5.

Figure 6-5 Frame Relay to ATM NW Interworking Detail

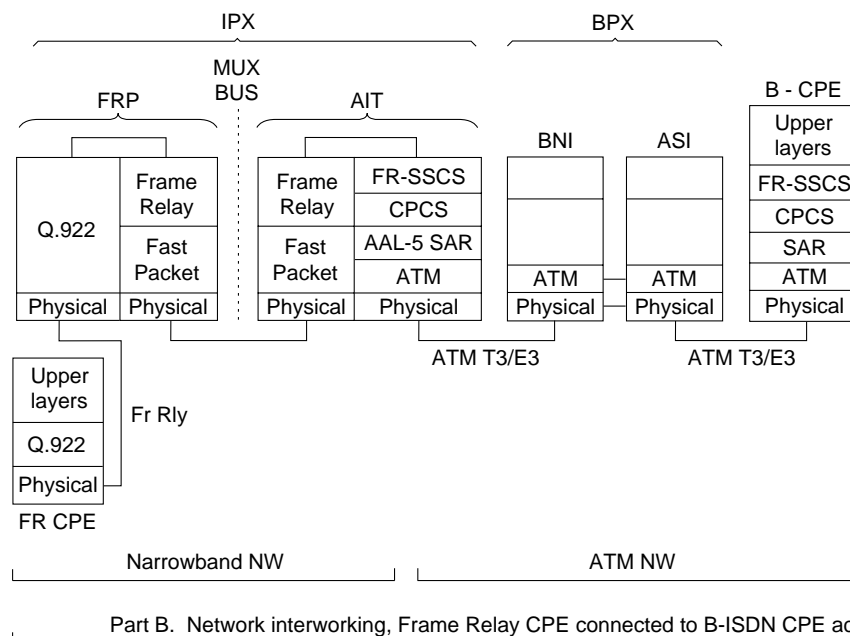
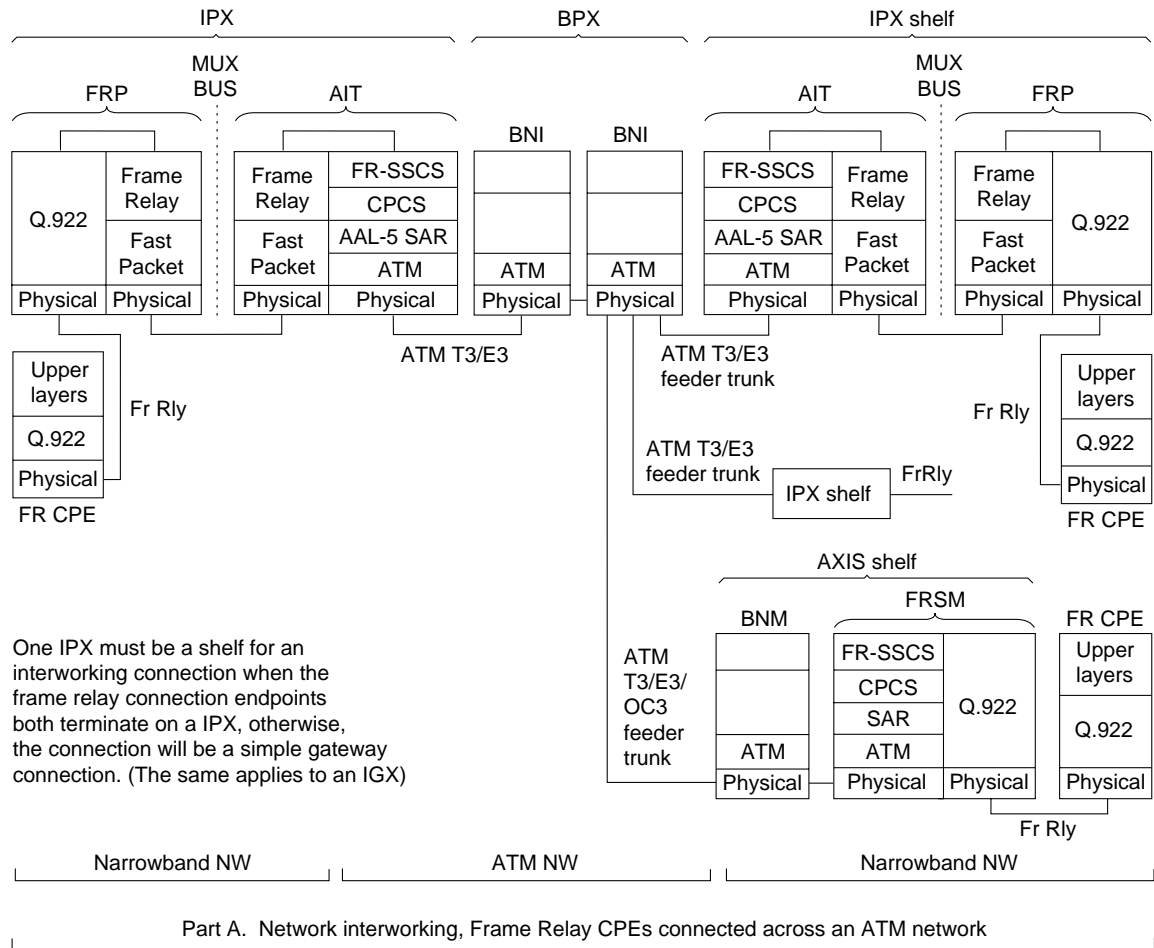

S6166

The frame relay to ATM networking interworking function is available as follows:

- IPX frame relay (shelf/feeder) to IPX frame relay (either routing node or shelf/feeder)
- AXIS frame relay to AXIS frame relay
- AXIS frame relay to IPX frame relay (either routing node or shelf/feeder)
- IPX frame relay (either routing node or shelf/feeder) to BPX or AXIS ATM port.
- AXIS frame relay to BPX or AXIS ATM port.
- In the items listed above, an IGX can be substituted for each instance of an IPX.

On the IPX, interworking is performed by the AIT card, and on the IGX by the BTM card. A simplified example of the connection paths is shown in Figure 6-6. In interworking, the AIT card receives FastPackets from the FRP, rebuilds the frames, and converts between frames and ATM cells. Data is removed from one package and placed in the other. Congestion information from the header is mapped to the new package. This processing by the AIT trunk card is called Complex Gateway. AIT trunk cards are required on every BPX to IPX hop in a Frame Relay to ATM connection's path.

Figure 6-6 ATF Connections, Simplified Example

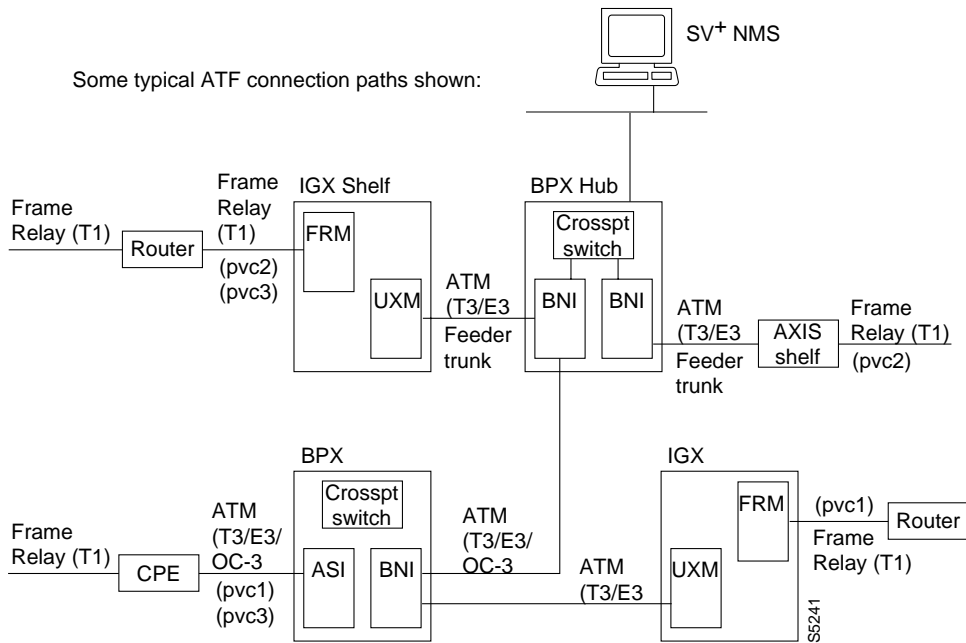

The cells within the frame are expected to possess the standard ATM Access Interface cell header. The traffic is assumed to have AAL-5 PDUs, and will not function properly otherwise (framing errors will result). Within the AAL-5 PDUs, the data must be packaged in standard frame relay frames, one frame per PDU (with respect to the AAL-5 layer).

The UPC and ForeSight algorithms are applied according to their configured values. The cell headers are converted into the proprietary StrataCom STI format before entering the network. The cells are delivered to their destination according to the configured route of the connection. Cells can be lost due to congestion.

Discard selection is based upon the standard CLP bit in the cells. When the routing path enters an IPX/IGX, an AIT/BTM card which supports Interworking traffic is required to convert the connection data from cells to frames (frames to fastpackets out onto MuxBus to FRP/cell bus to FRM), and visa versa. Additionally, the AAL-5 framing is removed upon conversion to frames, and added upon conversion to cells. At the destination (FRP), FastPackets are placed in the port queue and, when a complete frame has been assembled, the frame is played out the remote port in the original format (as provided in the frames delivered inside AAL-5 PDUs).

For each connection, only a single dlci can be played out for all traffic exiting the port, and is inserted into the frame headers. The standard LAPD framing format is played out the port on the FRP/FRM.

At the AIT/FRM card, several additional protocol mappings take place. First, the Interworking Unit acts as a pseudo endpoint for the purposes of ATM for all constructs which have no direct mapping into Frame Relay, such as loopbacks and FERF indications. Thus, end-to-end loopback OAM cells which come to AIT/FRM cards are returned to the ATM network without allowing them to proceed into the Frame Relay network, which has no equivalent message construct. Further, AIS and supervisory cells and FastPackets (from the Frame Relay direction) are converted into their counterparts within the other network.

ATM Protocol Stack

A general view of the ATM protocol layers with respect to the Open Systems Interconnection model is shown in Figure 6-7. In this example, a large frame might be input into the top of the stacks. Each layer performs a specific function before passing it to the layer below. A protocol data unit (PDU) is the name of the data passed down from one layer to another and is the Service Data Unit (SDU) of the layer below it. For Frame Relay to ATM interworking, a specific convergent sublayer, Frame Relay Service Specific Convergent Sublayer, FR-SSCS is defined. This is also referred to as FR-CS, in shortened notation.

Figure 6-7 ATM Layers

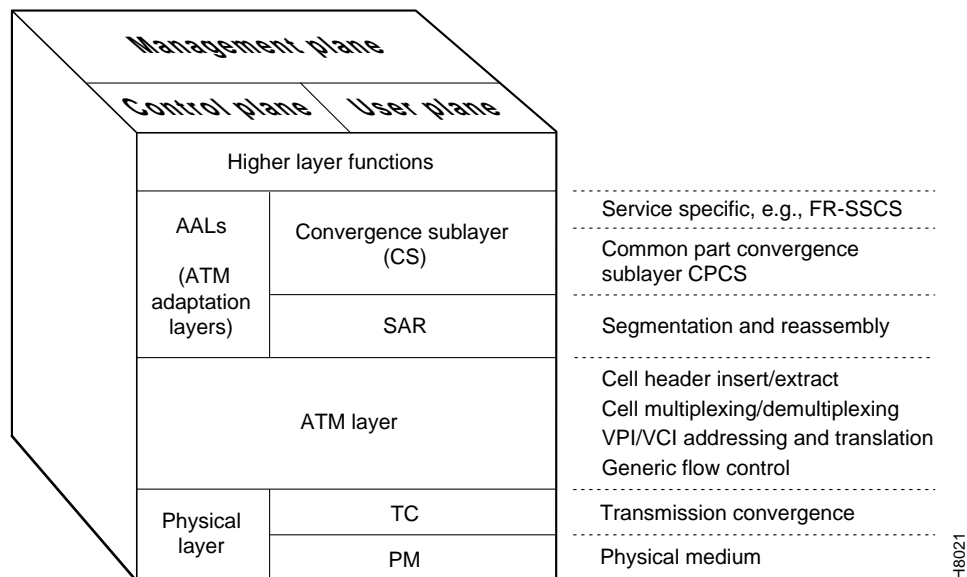

H8021

AIT/BTM Interworking and the ATM Protocol Stack

ATM to Frame Relay interworking (ATF) performs various tasks including the following:

- Conversion of PDUs between the frame relay and ATM virtual circuits of the frame relay and ATM user devices.
- Conversion between frame relay traffic service and ATM quality of service parameters
- Mapping of management status, including connection, port, line, and trunk status and events

Figure 6-8 depicts the function of the protocol stack layers in the interworking between ATM and Frame Relay PDUs. Interworking by the AIT/BTM card in the IPX/IGX includes the following functions:

- Translating the ATM pvc identifier (vpi.vci) to the frame relay pvc identifier (dlci) and vice versa
- Mapping the Protocol Data Unit (PDU), which is essentially the data, between the Frame Relay Service Specific Convergence Sublayer (FR-SSCS) and the Frame Relay Q.922 core protocol, and vice versa.
- On the IPX, Incoming Frames are converted to FastPackets by the FRP card. The FastPackets are then routed to the AIT card via the IPX MUX bus and converted back into Frame Relay Q.922 frames by the AIT card. Then the AIT card interworking function executes four layers to convert the Frame PDU to ATM cells:
 - the FRCS layer (Frame Relay Service Specific Convergence Sublayer, FRSSCS, or FRCS for in shortened notation) which uses a PDU format identical to the Q.922 core (without CRC-16 or flags),
 - the CPCS layer (Common Part Convergence Sublayer) which appends a CS-PDU trailer to the FR-PDU to create a CS-PDU
 - the Segmentation and Reassembly layer (SAR) which segments the CS-PDU (Protocol Data Unit) into SAR-PDUs (48 byte data entities)
 - and the ATM layer which attaches an ATM header to each SAR-PDU to create an ATM-SDU (Service Data Unit). The same process is performed in the reverse order by the AIT card when transforming cells to frames.

Figure 6-8 Protocol Stack Operation

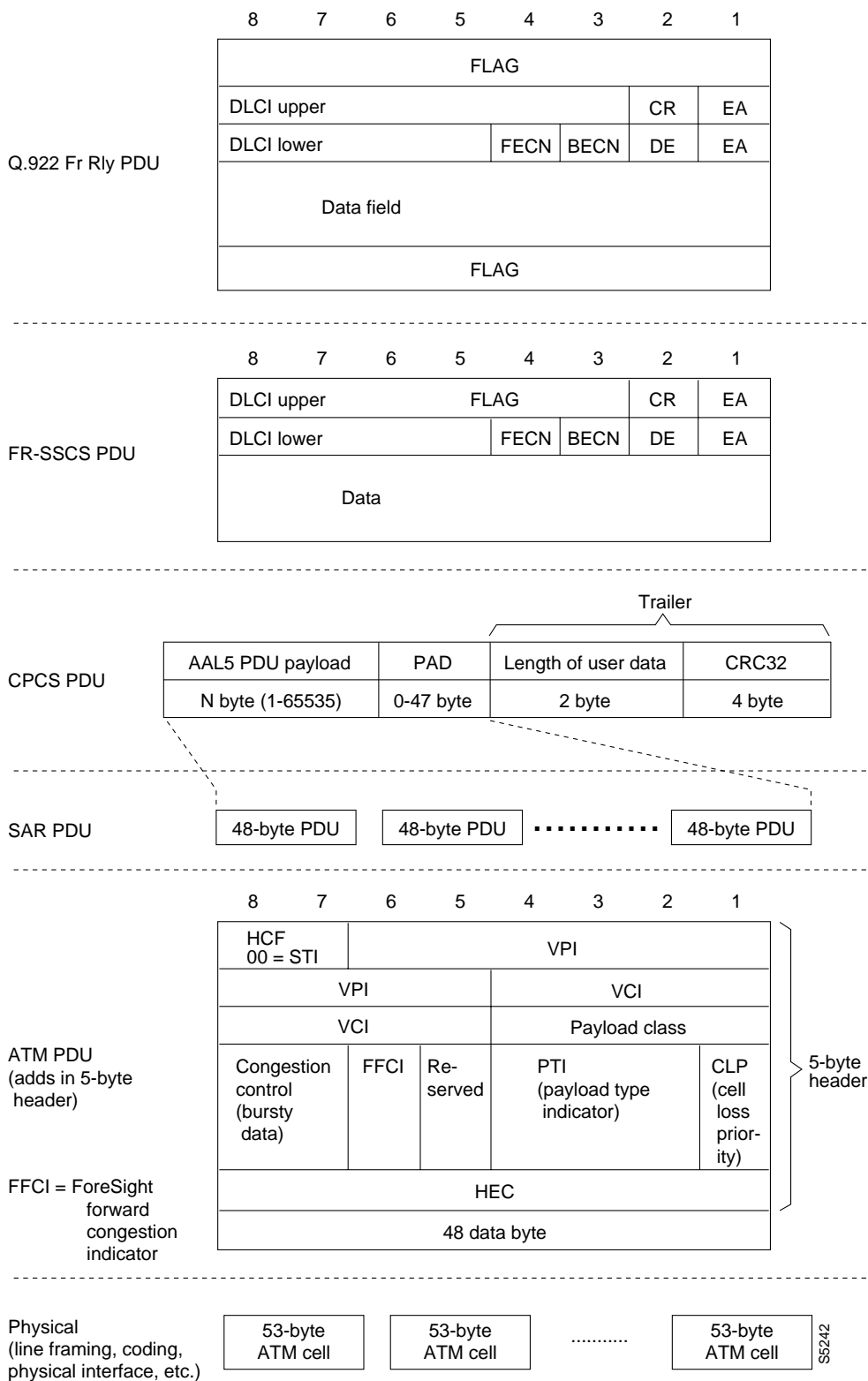

AIT/BTM Control Mapping, Frames and Cells

In addition to performing DLCI to PVC/VCC conversion, the network interworking feature provided by the AIT card in the IPX or BTM in the IGX maps cell loss priority, congestion information, and management information between frame relay and ATM formats as follows:

CELL LOSS PRIORITY, Frame Relay to ATM Direction

Each frame relay to ATM network interworking connection can be configured as one of the following DE to CLP mapping choices:

- The DE bit in the frame relay frame is mapped to the CLP bit of every ATM cell generated by the segmentation process.

The following 2 choices are not available on IPX/IGX NIW (network interworking):

- CLP is always 0
- CLP is always 1

CELL LOSS PRIORITY, ATM to Frame Relay Direction

Each frame relay to ATM network interworking connection can be configured as one of the following CLP to DE mapping choices:

- If one or more ATM cells belonging to a frame has its CLP field set, the DE field of the frame relay frame will be set.

The following choice is not available:

- Choosing no mapping from CLP to DE

CONGESTION INDICATION, Frame Relay to ATM direction

- EFCI is always set to 0.

CONGESTION INDICATION, ATM to Frame Relay Direction

- If the EFCI field in the last ATM cell of a segmented frame is set, then FECN of the frame relay frame will be set.

For PVC Status Management

The AIT/BTM does convert OAM cells to OAM fastpackets, and vice-versa, including the AIS OAM. Also, "A-bit" status is now propagated via software messaging.

The ATM layer and frame relay PVC Status Management can operate independently. The PVC status from the ATM layer will be used when determining the status of the FR PVCs. However, no direct actions of mapping LMI A bit to OAM AIS will be performed.

Management, OAM Cells

OAM cell processing:

- F5 OAM loopback
- AIS
- FERF
- StrataCom Internal OAM

Functional Description

ATF Summary

Features

- Interworking: ATM to Frame Relay connections
- Connection Statistics
- Round Trip Delay measurements incorporated into the ForeSight algorithm
- Frame Based GCRA (FGCRA). This is an enhancement of the Generic Cell Rate Algorithm
- IBS (Initial Burst Size)
- cnfportq: 3 egress port queues are configurable CBR, VBR and VBR w/Foresight. (Queue Bin numbers and algorithm types are NOT user selectable.)
- BCM (Backward Congestion Messages)
- ILMI and associated configuration options and statistics
- Loopback functions: **tstdly**, **tstconseg**, **addrmtlp**, **addloclp**
- Selftest/ Background tests
- OAM flows: AIS, FERF, OAM loopback
- ASI/2 E3 support
- End-to-end status updates (per FR/ATM interworking)
- Annex G and associated configuration options and statistics
- ASI-1 as a clock source is supported.

Limitations

- Priority Bumping is not supported across the interface shelves, but is supported across the routing network.
- Statistical Line Alarms per Software Functional Specification (i.e., Bellcore standards).
- Programmable Opti Class: although 4 connection classes are supported: CBR, VBR, VBR with Foresight, ATF, and ATF with ForeSight. Configuration of egress port queues and BNI trunk queues for these connection classes is available.
- Port loopback “**tstport**”

- Test “**tstcon**” not supported at BPX endpoints; it is supported at IPX endpoints
- Gateway terminated inter-domain connections
- Via connections through IPX

Some ATF Connection Criteria

ATF connections are allowed between any combination of ATM and Frame Relay UNI and NNI ports. Virtual circuit connections are allowed. Virtual path connections are not.

ATF connections can be mastered by the IPX or BPX end.

ATF bundled connections and ATF point-to-point connections are not supported.

ATF connections use the frame relay trunk queues: bursty data A for non-ForeSight, bursty data B for ForeSight.

Bandwidth related parameters are defined using cells per second (cps) on the BPX, and bits per second (bps) on the IPX/IGX. On a given endpoint node, the bandwidth parms for both ends of the ATF connection are changed/displayed using this end’s units. This saves the user from having to convert from cps to bps repeatedly.

ATF connections use the VBR egress queue on the ASI-1 card. ATF with ForeSight connections use the ABR egress queue.

Connection Management

The following user commands are used to provision and modify ATF connections:

- **addcon**
- **cnfcls**
- **cnfcon**
- **delcon**
- **dspcls**
- **dspcon**
- **dspcons**

Port Management

The following features are added to the ASI-1 at the port level:

- An ASI-1 card can be configured to use the network-network interface (NNI) addressing format. This feature is only available on a per-card level, so changing one port to or from NNI changes the other one also, with appropriate warnings to the user.
- ILMI activation/configuration/statistics
- LMI Annex G activation/configuration/statistics
- Port egress queue configuration
- Backward congestion management

Structure

- NNI
- The NNI format supports a 12-bit VPI. A-bit status changes are passed to the remote end of the connection.
- ILMI
- The ILMI MIB and protocol was implemented in release 7.2. The additional support in consists of an activation and configuration interface, collection of statistics, and end-to-end status updates.
- LMI Annex G
- The LMI Annex G protocol was implemented in release 7.2. The additional support consists of an activation and configuration interface, collection of statistics, and end-to-end status updates.
- Port egress queue configuration
- Each of the pre-defined ASI-1 port egress queues can be configured by the user. These queues consist of CBR, VBR, and VBR with ForeSight (ABR). The configurable parameters are queue depth, EFCN threshold, and CLP thresholds.
- Backward congestion management
- Backward congestion management cells indicate congestion across the UNI or NNI. Transmission of these cells is enabled on a per-port basis. Software allows BCM to be configured on a UNI or NNI port for maximum flexibility should BCM over UNI be standards-defined.

The following user commands are used to configure ASI-1 port features:

- **cnfport**
- **cnfportq**

Channel Statistics

Statistics are supported on a per-channel basis. A range of traffic and error statistics are available. ASI-1 channel statistics are enabled by StrataView+ or by the BPX control terminal using the existing statistics mechanism. The existing collection intervals apply.

Channel statistics of the following general types are supported:

- Cells received/transmitted, dropped, tagged as non-compliant or congested
- Cell errors
- AAL-5 frame counts, errors

The following user commands are used to configure and display channel statistics

- **clrchstats**
- **cnfchstats**
- **dspchstats**
- **dspchstatcnf**
- **dspchstathist**

OAM Cell Support

OAM cells are detected and transmitted by the ASI-1 firmware. System software displays alarm indications detected by the firmware. Additionally, loopbacks between the ATM-UNI and the ATM-CPE can be established. ForeSight round-trip delay cells are generated by firmware upon software request.

System software deals with the following OAM cell flows:

- End-to-End AIS/FERF—software displays on a per-connection basis.
- External segment loopbacks—software initiates loopback of ATM-CPE via user command. The SAR creates the loopback OAM cell. External loopback cells received from the ATM-CPE are processed by the SAR.
- Internal ForeSight round trip delay—software commands the ASI-1 to measure the RTD excluding trunk queueing delay on each ForeSight connection. Software displays the result.
- Internal loopback round trip delay—software commands the ASI-1 to measure the RTD including trunk queueing delay on each ForeSight connection. Software displays the result.
- Internal Remote Endpoint Status—these cells are generated by one end of a connection due to remote network connection failure (A-bit = 0). The other end ASI-1 detects these cells and reports the connection status to software, which displays it.

The following user commands are associated with OAM cell status changes:

- **dspalms**
- **dspcon**
- **dspport**
- **tstconseg**
- **tstdly**

Diagnostics

- Loopbacks
- Local loopbacks loop data back to the local ATM-TE, via the local BPX. Remote loopbacks loop data back to the local ATM-TE, via the whole connection route up to and including the remote terminating card.
- Local and remote connection loopbacks, and local port loopbacks, are destructive.
- Card Tests
- The generic card selftest mechanism on the BPX is modified to include the ASI-1 card.
- The card background test that exists for the FRP card on the IPX is modified to work for the ASI-1 card.
- Connection Tests
- The tstcon command is not supported. The tstdly command is used for connection continuity testing. ASI-1 tstdly is non-destructive, as compared with the IPX tstdly.

User Commands

The following user commands are associated with diagnostics changes:

- **addloclp**
- **addrmtlp**
- **cnftstparm**
- **dellp**
- **dspalms**
- **dspcd**
- **dspcds**
- **tstdly**

Virtual Circuit Features

The following virtual circuit features are supported by the ASI-1:

- Connection Groups

Connection groups are supported for ASI-1 ATM and interworking connection types, allowing termination of up to 5000 (grouped) virtual circuits per BPX node. The connection grouping feature currently available on frame relay connections is expanded to include ASI-1 ATM and interworking connections.

- FGCRA

Frame-Based Generic Cell Rate Algorithm is an ASI-1 firmware feature that controls admission of cells to the network. It is configurable on a per-connection basis. It is a StrataCom enhancement of the ATM-UNI standard Generic Cell Rate Algorithm. System software allows configuration of FGCRA on a per-connection basis.

- IBS

Initial Burst Size is an ATM bandwidth parameter that is used by firmware to allow short initial bursts, similar to the Cmax mechanism on the IPX. It is configurable on a per-connection basis

- Full VPI/VCI addressing range

The entire range of VPI and VCI on both UNI and NNI interfaces is supported. For ATM-UNI, 8 bits of VPI and 16 bits of VCI are supported. For ATM-NNI, 12 bits of VPI and 16 bits of VCI are supported. In either case, VPC connections only pass through the lower 12 bits of the VCI field.

- Connection Classes

ATM and interworking connection classes are defined with appropriate bandwidth parameter defaults. These classes only apply at addcon time. They are templates to ease the user's task of configuring the large number of bandwidth parameters that exist per connection.

User Commands

The following user commands are associated with virtual circuit feature changes:

- **addcon**
- **addcongrp**
- **cnfcon**
- **cnfatmcls**
- **delcon**
- **delcongrp**
- **dspatmcls**
- **dspcongrps**
- **grpcon**

AUser Commands

The following user commands are modified to support ASI-1 E3:

- **cnfln**
- **cnflnstats**
- **dspcd**
- **dspcds**
- **dsplncnf**
- **dsplns**
- **dsplnstatcnf**
- **dsplnstathist**
- **dspyred**
- **prtyred**

Management

Connection Management

Interworking connections may be added from either the BPX, the IPX, the IGX, or the AXIS. Intra- and inter-domain interworking connections are supported.

Connection configuration parameters are endpoint-specific. Thus, the ATM-only parameters are only configurable on the BPX end. The IPX does not know about these parameters, so they cannot be configured or displayed at the IPX end. Parameter units are endpoint-specific also. Units on the BPX are cells per second, units on the IPX are bits per second.

Bundled interworking connections are not supported.

Virtual path interworking connections are not supported.

Routing

Interworking connections use the complex gateway feature of the AIT trunk card to repackage data from frames to ATM cells, and vice-versa. All BPX-IPX hops these connections route over must provide the complex gateway function. IPX-IPX hops (frame relay connections) can be any trunk card type. This requirement simplifies the routing mechanism when dealing with structured networks, as software does not know the type of trunks in remote domains.

Bandwidth Management

Bandwidth calculations for interworking connections assume a large frame size, which minimizes the loading inefficiency of packets vs. cells. In other words, the translation between packets and cells assumes 100 percent efficiency, so the conversion is simply based on 20 payload bytes per fastpacket vs. 48 payload bytes per ATM cell.

This mechanism keeps the fastpacket/cell conversion consistent with the bits per second/cells per second conversion. Thus, conversion of endpoint rates to trunk loading is straightforward.

User Interface

ATM connection classes are added for convenience. Classes can be configured as interworking or regular ATM. The **cnfcls** command is used to configure a class. The class is specified as part of the **'addcon'** command. ATM connection classes are maintained on all BPX nodes. IPX nodes do not know about these classes.

A special ATM class is defined as the default interworking class. When an interworking connection is added from the frame relay end, the ATM-only parameters for this connection are taken from this default class.

Network-wide ForeSight parameters are supported for the frame relay end of interworking connections. The **'cnfstparm'** command is used to configure these parameters. Since the ATM end of interworking connections has per-virtual circuit ForeSight parameter configurability, the network-wide ForeSight parameters do not apply.

Note that the default ATM ForeSight parameters will match the default frame relay ForeSight parameters, with appropriate units conversion.

Port Management

The **'cnfport'** command supports the following new features:

- An ASI-1 card can be configured to be UNI or NNI.
- An ASI-1 UNI or NNI port can be configured to transmit Backwards Congestion Messages (BCM) to indicate congestion to the foreign ATM network.
- An ASI-1 UNI or NNI port can be configured for LMI, ILMI, or no local management.

The **'cnfportq'** command supports configuration of queue depth, EFCN threshold, and CLP thresholds for all port egress queues (CBR, VBR, VBR w/ForeSight).

Connection Management

The NNI cell format has 12 bits for the VPI, so 'addcon' allows specification of VPI 0-4095 on NNI ports.

Signaling

System software supports the following LMI/ILMI signaling actions:

- Internal network failure: software informs LMI/ILMI to set A bit = 0 for failed connections. Software informs ASI-1 to transmit AIS to port for failed connections.
- Port failure/LMI Comm Failure: software informs remote nodes terminating all affected connections. Remote node BCC informs LMI/ILMI to set A bit = 0, and ASI-1 to transmit AIS.
- LMI A = 0: software polls ILMI agent periodically for A-bit status. Status changes are reflected in the 'dspcon' screen.

Alarms

LMI communication failure on an ASI-1 causes declaration of a minor alarm. The 'dspport' screen shows the failure, as does the 'dspalms' screen.

A-bit = 0 on an NNI port causes declaration of a minor alarm. The 'dspcon', 'dspcons', and 'dspalms' screens show this failure.

Tiered Networks

This chapter describes the tiered network architecture that supports interface shelves (non-routing nodes) connected to an IPX/IGX/BPX routing network.

The chapter contains the following:

- Introduction
- BPX Routing Hubs in a Tiered Network
- StrataView Plus NMS

With Release 8.5, tiered networks now support voice and data connections as well as frame relay connections. With this addition, a tiered network can now provide a multi-service capability (frame relay, circuit data, voice, and ATM). By allowing CPE connections to connect to a non-routing node (interface shelf), a tiered network is able to grow in size beyond that which would be possible with only routing nodes comprising the network.

Routing Hubs and Interface Shelves

In a tiered network, interface shelves at the access layer (edge) of the network are connected to routing nodes via feeder trunks (Figure 7-1). Those routing nodes with attached interface shelves are referred to as routing hubs. The interface shelves, sometimes referred to as feeders, are non-routing nodes. The routing hubs route the interface shelf connections across the core layer of the network.

The interface shelves do not need to maintain network topology nor connection routing information. This task is left to their routing hubs. This architecture provides an expanded network consisting of a number of non-routing nodes (interface shelves) at the edge of the network that are connected to the network by their routing hubs.

Frame relay connections originating at IPX and IGX interface shelves and frame relay, ATM, CESM, and FUNI connections originating at AXIS interface shelves are routed across the routing network via their associated BPX routing hubs. Frame Relay connections originating at IGX interface shelves connected to IGX routing hubs may also be routed across BPX intermediate nodes.

Voice and data connections originating and terminating on IGX interface shelves (feeders) are routed across the routing network via their associated IGX routing hubs. Intermediate routing nodes must be IGX nodes. Refer to the *Cisco StrataCom System Overview* and *IGX Reference* manuals for additional information on IGX routing hubs and IGX interface shelves.

Note The IGX may also be configured as an interface shelf feeding frame relay connections to a BPX routing hub.

Figure 7-1 Tiered Network with BPX and IGX Routing Hubs

BPX Routing Hubs in a Tiered Network

Tiered networks with BPX routing hubs have the capability of adding interface shelves/feeders (non-routing nodes) to an IPX/IGX/BPX routing network (Figure 7-2). The AXIS interface shelf, and IPX or IGX nodes configured as interface shelves are connected to BPX routing hubs. Interface shelves allow the network to support additional connections without adding additional routing nodes.

The AXIS supports frame T1/E1, X.21 and HSSI frame relay, ATM T1/E1, and CES, and is designed to support additional interfaces in the future. The IPX interface shelf supports frame relay ports, as does the IGX (option is available to configure as an interface shelf).

Figure 7-2 Tiered Network with BPX Routing Hubs

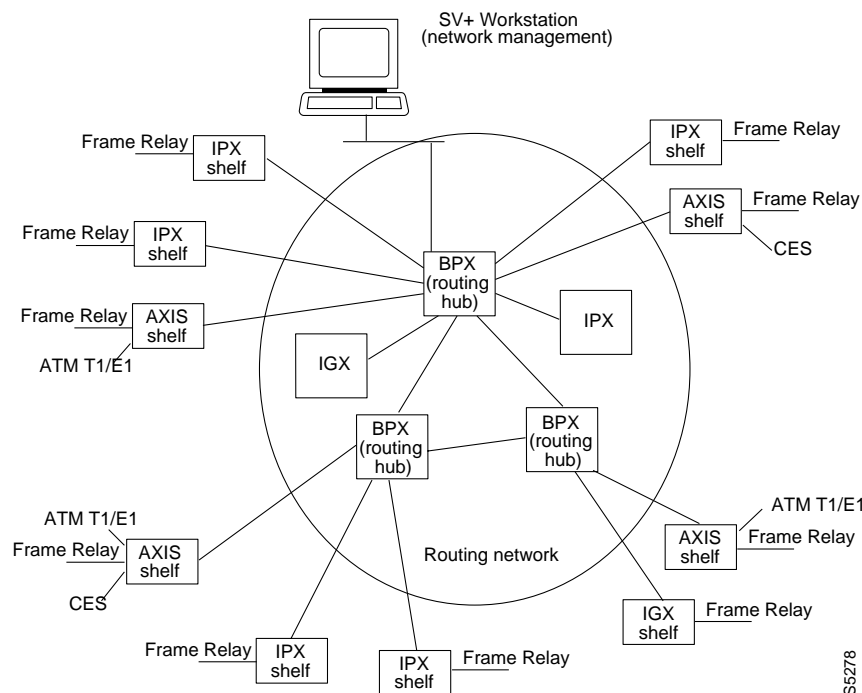

S5278

Tiered Network Implementation

The following requirements apply to BPX routing hubs and their associated interface shelves:

- AXIS Release 4 level is required on all AXIS interface shelves.
- Only one feeder trunk is supported between a routing hub and interface shelf.
- No direct trunking between interface shelves is supported.
- No routing trunk is supported between the routing network and interface shelves.
- The feeder trunks between BPX hubs and IPX or IGX interface shelves are either T3 or E3.
- The feeder trunks between BPX hubs and AXIS interface shelves are T3, E3, or OC3-c/STM-1.
- Frame Relay Connection management to an IPX interface shelf is provided by StrataView Plus

- Frame Relay and ATM connection management to an AXIS interface shelf is provide by StrataView Plus
- Telnet is supported to an interface shelf; the vt command is not.
- Remote printing by the interface shelf via a print command from the routing network is not supported.

General

Annex G, a bi-directional protocol, defined in Recommendation Q.2931, is used for monitoring the status of connections across a UNI interface. Tiered Networks use the Annex G protocol to pass connection status information between a Hub Node and attached interface shelf.

Definitions

BPX Service Note Routing Hub	A BPX Service node in the routing network which has attached interface shelves. Also referred to as a hub node or BPX hub.
AXIS Interface Shelf	A standards based service interface shelf that connects to a BPX routing hub, aggregates and concentrates traffic, and performs ATM adaption for transport over broadband ATM networks.
IPX Interface Shelf	A special configuration of the IPX narrow band node designated as a interface shelf that supports frame relay connections.
IGX Interface Shelf	A special configuration of the IGX multi-band node designated as a interface shelf that supports frame relay connections.
Feeder Trunk	Refers to a trunk which interconnects an interface shelf with the routing network via a BPX routing hub. A feeder trunk is sometimes referred to as an interface shelf trunk.
IPX/AF	Another name for the IPX interface shelf
IGX/AF	Another name for the IGX interface shelf
Routing Network	The portion of the tiered network which performs automatic routing between connection endpoints.
VPI	Virtual Path Identifier
VCI	Virtual Connection Identifier

Upgrades

Converting an IPX or IGX node to an interface shelf requires re-configuring connections on the node, as no upgrade path is provided in changing a routing node to an interface shelf.

A BPX node, acting as a Hub Node, is not restricted from providing any other feature which is normally available on BPX nodes. A BPX Hub supports up to 16 interface shelves.

Connections within tiered networks consist of distinct segments within each tier. A routing segment traverses the routing network, and an interface shelf segment provides connectivity to the interface shelf end-point. Each of these segments are added, configured and deleted independently of the other segments. The SV+ Connection manager provides management of these individual segments as a single end-to-end connection.

Interface shelves are attached to the routing network via a BPX routing hub using a BXM trunk (T3/E3 or OC3) or BNI trunk (T3/E3). The connection segments within the routing network are terminated on the BNI feeder trunks.

All frame relay connection types which can terminate on the BPX ASI card are supported on the BNI feeder trunk (currently VBR, CBR, ABR, and ATF types). No check is made by the routing network to validate whether the connection segment type being added to a BNI feeder trunk is actually supported by the attached interface shelf.

Co-locating Routing Hubs and Interface Shelves

The trunk between an interface shelf and the routing network is a single point of failure, therefore, the interface shelves should be co-located with their associated hub node. Card level redundancy is supported by the Y-Cable redundancy for the BXM, BNI, AIT, and BTM.

Network Management

Communication between CPE and the routing network is provided in accordance with Annex G of Recommendation Q.2931. This is a bidirectional protocol for monitoring the status of connections across a UNI interface. (Note: the feeder trunk uses the STI cell format to provide the ForeSight rate controlled congestion management feature.)

Communication includes the real time notification of the addition or deletion of a connection segment and the ability to pass the availability (active state) or unavailability (inactive state) of the connections crossing this interface.

A proprietary extension to the Annex G protocol is implemented which supports the exchange of node information between an interface shelf and the routing network. This information is used to support the IP Relay feature and the Robust Update feature used by network management.

Network Management access to the interface shelves is through the IP Relay mechanism supported by the SNMP and TFTP projects or by direct attachment to the interface shelf. The IP Relay mechanism relays traffic from the routing network to the attached interface shelves. No IP Relay support is provided from the interface shelves into the routing network.

The BPX routing hub is the source of the network clock for its associated feeder nodes. Feeders synchronize their time and date to match their routing hub.

Robust Object and Alarm Updates are sent to a network manager which has subscribed to the Robust Updates feature. Object Updates are generated whenever an interface shelf is added or removed from the hub node and when the interface shelf name or IP Address is modified on the interface shelf. Alarm Updates are generated whenever the alarm state of the interface shelf changes between Unreachable, Major, Minor and OK alarm states.

An interface shelf is displayed as a unique icon in the SV+ Network Management topology displays. The colors of the icon and connecting trunks indicate the alarm state of each. Channel statistics are supported by FRP, FRM, , ASI, and AXIS endpoints. BNIs, AITs, and BTMs do not support channel statistics. Trunk Statistics are supported for the feeder trunk and are identical to the existing BNI trunk statistics.

ForeSight

Foresight for an IPX interface shelf terminated Frame Relay connections is provided end-to-end between Frame Relay ports, regardless as to whether these ports reside on an IPX interface shelf or within the routing network.

Preferred Routing

Preferred routing within the routing network can be used on all connections. Priority bumping is supported within the routing network, but not in the interface shelves. All other connection features such as conditioning, **rrtcon**, **upcon**, **dncon**, etc. are also supported.

Local and Remote Loopbacks

Connection local and remote loopbacks are managed at the user interface of the FRP endpoint routing node or interface shelf. The existing IPX Frame Relay port loopback feature is supported on the IPX interface shelf. Remote loopbacks are not supported for DAX connections. A new command **addloormtlp** is added to support remote loopbacks at FRP DAX endpoints.

Testcon and Testdly

Tstcon is supported at the FRP endpoints in a non-integrated fashion and is limited to a pass/fail loopback test. Fault isolation is not performed. This is the same limitation currently imposed on inter-domain connections. Intermediate endpoints at the AIT and BNI cards do not support the tstcon feature. Tstdelay is also supported for the FRP and ASI in a non-integrated fashion similar to that of the tstcon command.

IPX Interface Shelf Description

The IPX interface shelf supports the termination of Frame Relay connection segments to an AIT. DAX voice and low speed data connections are also supported, but they can't terminate on an AIT. The IPX interface shelf connects to the routing network via an AIT card on the IPX and a BNI card on the BPX routing hub.

Admission control and ForeSight rate control for IPX interface shelf terminated Frame Relay connections is performed at the FRP port on the IPX interface shelf. Only a single trunk line is supported between the IPX interface shelf and the routing network. Trunks on the IPX interface shelf linking other nodes are not supported.

Frame Relay type connections, remotely or locally terminated are supported on IPX interface shelves. Interface shelf connections for which both endpoints reside on the same interface shelf are not known to the routing network and will not route through the routing network.

IPX interface shelves support the following network management features:

- Interval Statistics enable/disable/collection
- IP Relay
- Robust Object Updates
- Robust Alarm Updates
- Real-time Counters
- Event Logging
- Software/Firmware Downloads

- Configuration Save/Restore
- SNMP

Configuration and Management

The interface shelves attached to each hub must have unique names. Each interface shelf must also be assigned a unique IP address.

An interface shelf communicates with a routing hub over a new type of NNI. It is similar to the existing Frame Relay NNI in purpose and function, and is based on the ATM LMI message set described by Recommendation 2931, Annex G. A routing hub and interface shelf use this NNI to maintain a control session with each other. Any change to the status of the feeder trunk affects this control session.

Feeder trunks are the communication path between the routing hub and the Feeder. These feeder trunks are supported by the AIT trunk card on the IPX interface shelf and the BNI trunk card on the BPX routing hub. Feeder trunks are upped using the “**uptrk**” command. Feeder trunks must be upped on both the routing hub and the interface shelf before it can be joined to the routing network.

Once an IPX has been converted to an interface shelf, it can be joined to the BPX routing hub, by executing the **addshelf** command at the BPX routing hub. The **addshelf** command has the following syntax:

Interface Shelf Management

addshelf <trunk> <shelf_type>

trunk slot.port

shelf_type I (IPX/AF) or A (AXIS)

delshelf <trunk> | <shelf_name> deletes interface shelf

dsptime: Displays feeder trunk status. BPX Hub nodes display the status of all attached Interface shelves. IPX interface shelves display a single status item, that of the attached BPX Hub node.

Alarm Management of Interface Shelf on the BPX Hub Node

dspalms A new field, interface shelf alarms, shows a count of the number of interface shelves which are Unreachable, in Minor Alarm, or in Major Alarm. The nnn-A bit status failures for shelf connections are also shown.

Alarm Management on the IPX Interface Shelf

- dspalms** A new field, routing network Alarms, shows a count of major and minor alarms in the routing network. Feeder A-bit connection status reported by Feeder NNI is shown in the “Connection A-Bit Alarms” field.
- dspnode:** Shows if the routing network is reachable and the attached BPX hub node.

Port Management

Uses existing commands

Connection Management

Parameters entered at SV+ when adding connection.

Bandwidth Management

Parameters entered at SV+ when adding connection. Bandwidth performance monitored by viewing selected statistics at SV+ NMS.

Statistics

Enabled and monitored via StrataView Plus.

StrataView Plus NMS

Interface shelf and feeder trunk information is reported to StrataView Plus by the routing hub and interface shelf. StrataView Plus can virtually connect to any node in the network via a TCP/IP connection. The StrataView Plus Connection Manager is used to add, delete, and monitor voice and data connections for tiered networks with IGX hubs. It is also used to add, delete and monitor frame relay connections for tiered networks with BPX hubs. A sample of the Connection Manager GUI is shown in Figure 7-3.

Figure 7-3 SV+ Connection Manager

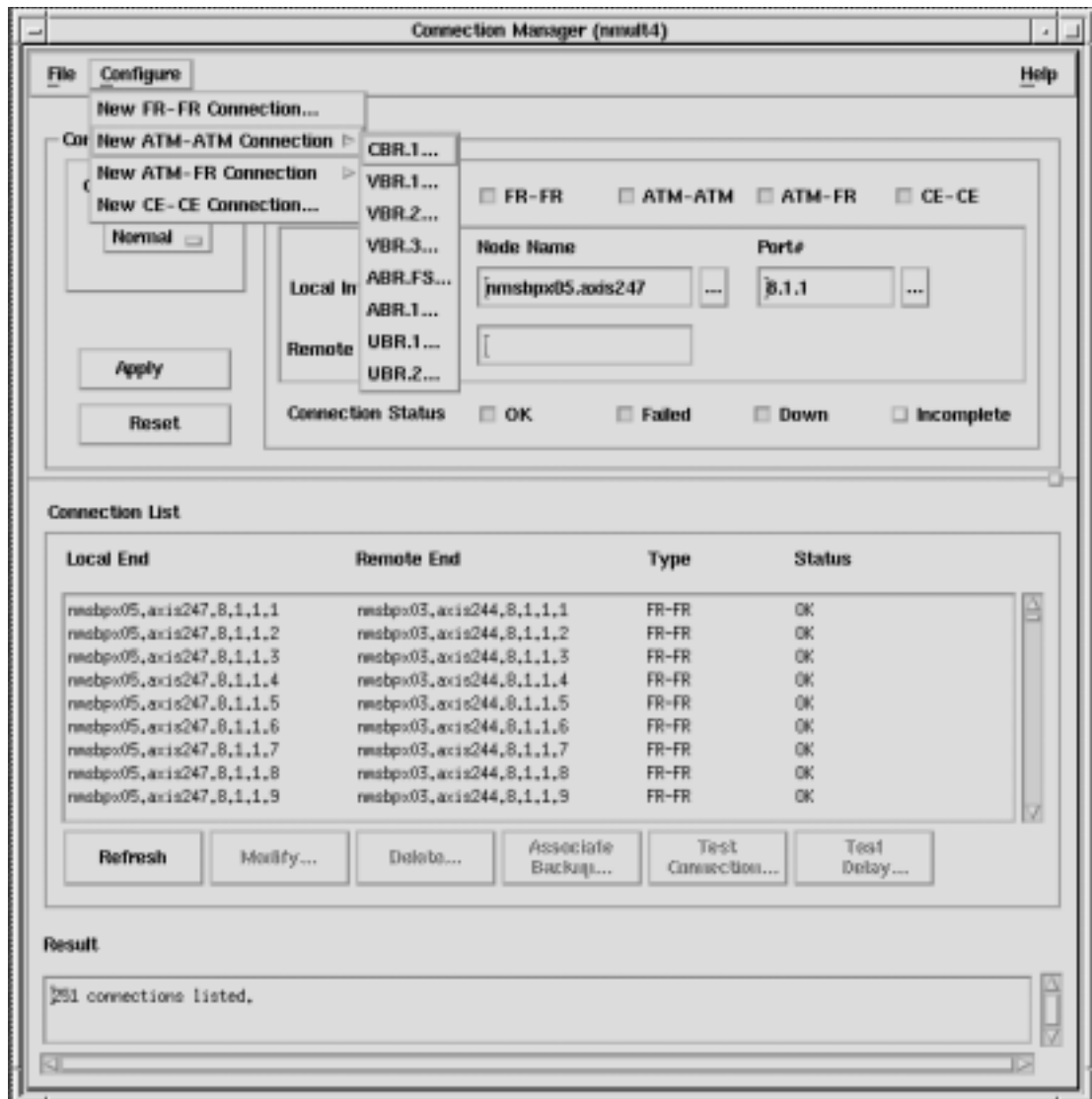

BPX SNMP Agent

This chapter introduces the functions of the Simple Network Management Protocol (SNMP) agent that is embedded in each BPX node. To benefit from this chapter, readers should have a general knowledge of SNMP, IP protocols, and MIBs.

The chapter contains the following:

- Introduction
- SNMP Overview
- SNMP Functions
- MIB II Support
- StrataCom Proprietary MIB Structure

Introduction

An SNMP agent is embedded in each BPX node. (This feature is an addition to and functionally different from the SNMP Proxy Agent that can be used by a non-SV+ workstation to provide access to a MIB on the SV+ workstation which contains data extracted from the SV+ Informix database.) The SNMP agent permits an SNMP manager to view and set certain network objects in Management Information Bases (MIBs) that are maintained in each BPX node within a managed network. The embedded SNMP agent supports the standard Internet MIB II, the ATM 3.1 UNI MIB, and a StrataCom proprietary MIB. The StrataCom proprietary MIB contains information necessary to control ports and connections on the switches in the network. The standard Internet MIB II contains MIB modules defined by the IESG (Internet Engineering Steering Group). SNMP support is available on both IPX and BPX switches.

The proprietary MIB is supplied on a tape for compilation into the user's SNMP manager.

SNMP Overview

An SNMP manager manages the SNMP agents in each BPX node in a single domain. To gain access to network nodes, the SNMP manager is connected to one of the BPX nodes through its Ethernet port, which acts as a gateway for the SNMP manager to communicate with all the other BPX nodes in the domain.

In multiple networks, a separate SNMP manager must exist for each network that is being managed. Furthermore, nodes within a multi-network can be managed by multiple SNMP managers. Also, ATM connections that span multiple networks are supported in the SNMP MIB.

Figure 8-1 shows an SNMP manager and the nodes within a domain.

Figure 8-1 SNMP Manager and Agents in a BPX Domain

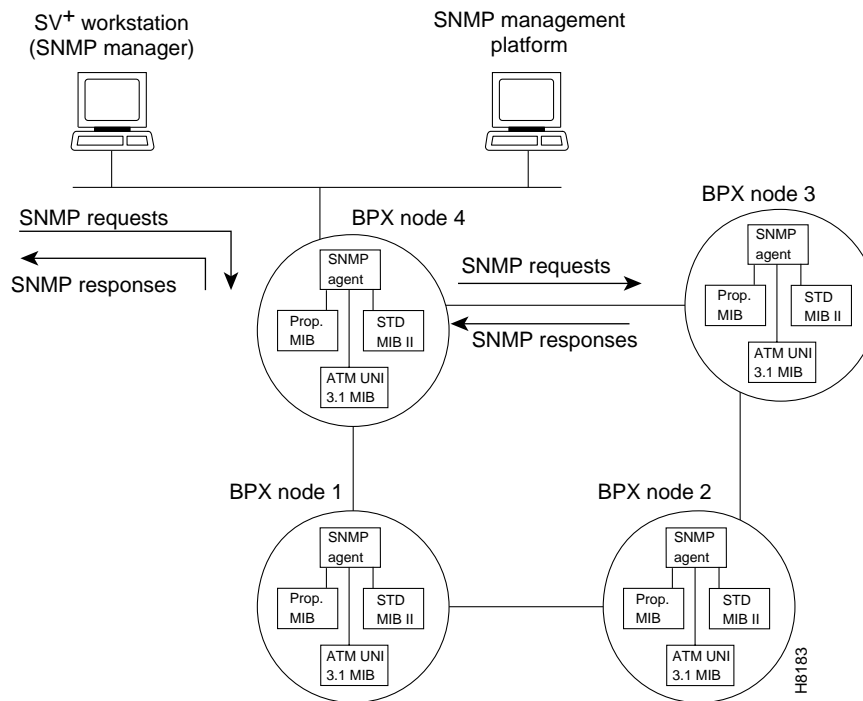

Communication between the agents and the SNMP manager uses the standard UDP protocol encapsulated within IP protocol. The communication link between the SNMP manager and the directly attached BPX node uses the Ethernet interface of an BCC processor card. The SNMP manager can be either local or remote to the BPX node.

Figure 8-1 illustrates the SNMP manager's communication with the agents in the network. Each node in the domain must have a network IP address assigned by the **cnfnwip** command (see Command Reference Manual for details). The manager uses the network IP address to address an agent in the domain. The directly attached node (Node 4 in Figure 8-1) directs the SNMP message to the addressed BPX node. Responses from the agent go to the directly attached node then pass over the Ethernet link to the SNMP manager.

Note The LAN IP address of the directly attached node must be configured with the **cnflan** command.

SNMP Functions

The SNMP protocol provides a basic query-response model for network management. The network manager has access to Get (Get-Next) and Set functions.

A Get request lets the manager read variables in the BPX. The request consists of a single variable or a list of variables. The BPX database subsequently returns the requested values.

The Get-Next request lets the manager obtain the successor to the given variable's object identifier. The returned object identifier can serve as input to another Get-Next request so the manager can lexicographically walk through the MIB.

A Set request lets the manager modify variables in the BPX. The request consists of either a single variable or a list of variables. The values supplied in the request modify the BPX database. The variables and their associated values in the request message are put into a response message and returned to the requesting management workstation. The format of the Set response message is the same as that of the Get response message.

SNMP requests from the manager have the same access level as non-privileged users. Non-privileged access can be read-only, read-write, or no access. To maintain access control, each Get and Set request is checked for the correct community string. The community string determines the access privileges that a management workstation has. A separate community string exists for Get requests and Set requests.

The node initializes the community strings to no access, so the user must set the strings to the appropriate values. The community strings can be set and displayed by the **cnfsnmp** and **dspsnmp** super-user commands, respectively (see the Super-User Command Reference Manual for details).

Responses to Get, Get-Next, and Set requests are returned in a response packet along with a status field. The status field can be one of the following:

- noError (0) Successful operation.
- tooBig (1) The agent could not fit the results of an operation into a single SNMP message.
- noSuchName (2) The requested operation identified an unknown variable when attempting to modify a variable.
- badValue (3) Requested operation specified an incorrect syntax or value when attempting to modify a variable.
- readOnly (4) Requested operation attempted to modify a variable that, according to the community profile, may not be written. (no longer supported by Standards)
- genErr (5) All other failure responses.

If an error occurs, the appropriate error code is encoded in ASN.1 format and inserted into the response packet.

Note In the sections that follow, user-specified command names are in lower case.

Responses to Get (Get-Next) Requests

When an SNMP manager workstation sends an SNMP Get request packet to a BPX agent, it utilizes the IP protocol for addressing. The request packet can use either a LAN interface for a locally attached management workstation or a network interface for remote access. Each packet is in ASN.1 format, which is suitable for transmission via the UDP protocol. Once it arrives, the packet is decoded to a Protocol Data Unit (PDU). This PDU is the SNMP internal packet structure.

A PDU consists of one or more variables requested by the manager. The PDU's community string is validated for correct access permissions, then the requested variables are collected within an SNMP varbind list for processing.

For each variable in the request message, the agent calls a user-defined test function that makes sure the requested variable exists. If the test confirms the existence of the variable, the agent calls a user-defined get function to gain access to the BPX database for the specified variable. The get function is appropriate for the type of request (Get or Get-Next).

A get function can read either a single scalar value or a single column entry from the database row. The user-defined get-next function provides a way to read a table of unknown elements. The get-next function returns the lexicographically next variable in the table with respect to the next variable. This mechanism lets the manager sequentially retrieve the entire table.

The test and get functions result in a Get response packet. If an error occurs, the appropriate error code is encoded in ASN.1 format and placed in the packet. If no errors occur, the returned values are encoded and placed in the response packet. The response packet goes to the workstation that originated the Get request.

ATM Set Requests

SNMP Set requests support the ATM functions in the following list. Refer to the *Command Reference* for command descriptions.

- Add ATM connection (**addcon**)
- Delete ATM connection (**delcon**)
- Up ATM connection (**upcon**)
- Down ATM connection (**dncon**)
- Modify ATM connection (**cnfrcon**, **cnfcos**, **cnfpref**, **cnfrcon**)
- Test ATM connections (**tstcon**, **tstdelay**)

SNMP Set requests can implement the following BPX commands on ATM ports:

- Up ATM port (**upfrport**)
- Down ATM port (**dnfrport**)
- Modify ATM port (**cnffrport**)

Responses to Set Requests

When an SNMP manager workstation sends an SNMP Set request packet to a BPX agent, it utilizes the IP protocol for addressing. The request packet can use either a LAN interface for a locally attached management workstation or a network interface for remote access. Each packet has the ASN.1 format, which is suitable for transmission via the UDP protocol. Once it arrives, the packet is decoded to a Protocol Data Unit (PDU). This PDU is the SNMP internal packet structure.

Each variable in the varbind list is located, checked for visibility in the current MIB view, checked for write-access, and type-matched against the set request. A user-defined function is then called to validate the Set PDU. This validation mainly determines if the Set request packet follows the guidelines defined for the BPX. This function returns either good status or an error. The error indicates the PDU is bad and should be rejected. Processing continues with tests for accessibility and acceptability.

Each variable in the varbind list is tested for accessibility and acceptability. User-defined test functions associated with each variable are called to implement the tests. A failed test returns a specifier for the variable and a reason code. Any failed test results in a failed Set request. Upon successfully passing the test functions, the set request can proceed to set the requested variables on the specified switch. The SNMP agent calls a user-specified set function to implement the modifications.

Upon either a successful completion or an error, the Set request PDU is modified to become the response PDU. The response PDU also contains the values of the variables in the original Set request. This PDU is encoded into ASN.1 format and inserted into the response packet. The Set response packet goes to the workstation that generated the request.

MIB II Support

The BPX SNMP agent supports the following groups in the Internet SNMP MIB II:

- ARP
- ICMP
- Interfaces
- IP
- SNMP
- System
- TCP
- UDP

StrataCom Proprietary MIB Structure

This section is an overview of the StrataCom proprietary MIB. The proprietary MIB resides under the enterprises branch of the SNMP tree structure (1.3.6.1.4.1.StrataCom (351)). For detailed information on the structure and contents of the MIB, refer to the actual MIB that is included on the release tape. The MIB is in ASN.1 format.

Note Release 8.2 of the MIB is backward compatible with the 8.1 and 8.0 MIB.

The MIB provides network managers with BPX information on a per switch basis. This information in the MIB relates to ATM service. The SNMP agent MIB has two major branches of information. These are the Switch Service Objects and Switch Connections.

Each variable in the MIB also includes the following:

- An access level (read-only, read-write, or no access)
- A defined MIB view, which allows appropriate agents to have access to platform-specific information

Switch Service Objects

The higher level Switch Services branch shows the available ATM services. This service information exists in a configuration table and a statistics table for each logical port on the switch. The configuration parameters for a logical port allow the manager to view and modify a specified available port. The statistics table gives the manager access to real-time counter statistics associated with a specified available port.

Switch Connections

The Switch Connections branch supports per switch management of ATM connections. In this branch, the MIB defines the following:

- Connections—a general view of all available ATM connections on a switch
- Endpoints
- Bandwidth class
- Endpoint Statistics
- Endpoint mapping

The following is a list of the categories of connection information:

- Local description (e.g., domain.node.slot.port.vpi.vci, group id) (read-only)
- Remote description (e.g., domain.node.slot.port.vpi.vci) (read-only)
- Status of the connection (read-only)
- Failure reasons (read-only)

- Current route information (read-only)
- Preferred route information (read-write)
- Access to open space information (read-only)
- Pointer to endpoint-specific information (read-only)

The ATM endpoint-specific information (last item in the previous list) provides the mechanism for the manager to provision and configure ATM connections. The available endpoint-specific information is:

- Local description (e.g., domain.node.slot.port.vpi.vci) (read-write)
- Remote description (e.g., domain.node.slot.port.vpi.vci) (read-write)
- ATM applicable bandwidth parameters (read-write)
- Foresight enable status (read-write)
- Trunk avoid types (read-write)
- Connection priority (read-only)
- Foresight round-trip delay (read-only)

Bandwidth Class

The bandwidth class information gives the manager a view of the available bandwidth classes that are configured on the switch. The manager can use a selected class as a template to create a ATM endpoint.

Endpoint Statistics

The endpoint statistics are real-time counter statistics about a specific endpoint.

Endpoint Mapping

The endpoint mapping information lets the manager have access to connection and endpoint-specific indices. The indices are associated with physical attributes of a connection (for example, *slot.port.vpi.vci*). The manager can use the indices returned to it to gain access to connection and/or endpoint-specific information.

BPX Node Specifications

This appendix lists preliminary information for the the BPX system specifications. (Refer to on-line documents for latest information).

General

System Capacity:	1 shelf with 15 card slots. Requires 1 or 2 dedicated slot(s) for BCC card. Requires 1 dedicated slot for ASM card.
Network Interface:	T3, E3, OC3, and OC12.
Network Trunks:	32 per node max.
Network Interface Protocol:	ATM layer using 53-byte cell.
Cell Switching:	Crosspoint switch matrix, non-blocking.
Switch Capacity:	9.6 Gbps or 19.2 Gbps (with BCC-4)
Slot Rate:	800 Mbps each, including overhead.
Connection Rate:	20 million cell connections/sec. between slots.
Classes of Service:	32 queues per port, assignable.
Clock Sources:	Internal, free-running oscillator, Stratum 3. Phase-locked to any appropriate network interface. External input at T1 or E1 rate
Clock Output:	Single clock output at T1 or E1 rate for synchronizing co-located IPX node(s) or CPE.
Cabinet Size:	22.75 inches (57.8 cm) high. 19.0 inches (48.25 cm) wide. 27.0 inches (68.6 cm) deep.

Weight, approx.	73 lb. (33.2 kg.) empty BPX shelf, w/fans but no PS. 6 lb. (2.7 kg.) each card. 18 lb. (8.2 kg.) empty AC Power Supply Tray. 16 lb. (7.3 kg.) each AC Power Supply 2 lb. (0.9 kg.) each DC Power Entry module.
Clearance Requirement:	At least 30 inches front and rear clearance; nominal 12 inch side clearance.
Power Source:	AC system: 180 – 264 VAC, 47 to 63 Hz. DC system: –42 to –56 VDC.
Power Requirements:	AC BPX-15: 13 A at 180 VAC (2300 VA). DC BPX-15: 40 A at –42 VDC (1680W).
Input Power Connector:	AC: 3-conductor IEC receptacle. 8 feet (2.4 m.) power cord supplied. DC: 3 Ring lug screw terminal connectors.
Circuit Breakers:	AC: 15 A on AC power supply assembly DC: 40A on power entry module
Fuses	Individual Backplane Card slot fuses, F1 through F3 for Fans 1 through 3, and F4 through F18 for card slots 1 through 15, respectively, 5A-120VAC rating
Operating Environment:	Operating Conditions are listed in Table A-1.
Shock:	Withstands 10G, 10 ms. at 1/2 sine wave.
Vibration	Withstands 1/4 G, 20–500 Hz.
Heat Transfer to Room:	Up to 7200 BTUs depending on node configuration.

Table A-1 Ambient Temperature and Humidity Limits

Conditions	Limits	
	Fahrenheit	Centigrade
Operating Temperature	+40 to +100 degrees	+4.5 to +38 degrees
Recommended	+68 to + 86 degrees	+20 to +30 degrees
Short-Term Temperature ¹	+35 to +120 degrees	+1.7 to + 49 degrees
Operating Relative Humidity	20% to 55% (non-condensing)	
Short-Term Relative Humidity	10% to 80% non-condensing	

1. Room temperature refers to conditions at a location 5 feet above the floor and 15 inches in front of the equipment.

ATM Trunk Interface (BXM-T3/E3 Cards)

Characteristic:	T3 (DS3)	E3
Line Rate	44.736 Mbps +/- 20 ppm	34.368 Mbps +/- 20 ppm
Line Code	B3ZS	HDB3
Cell Transfer Rate	96,000 cells per second	80,000 cells per second
Framing	ANSI T1.107, T1.107a	ITU T G804, G.832
Signal Level	TA-TSY-000773 (PLCP)	ITU-T G.703
Transmission Convergence Sublayer	DS3 PLCP frame format DS3 HEC mapped format	G.832 E3 frame format

T3 (DS3) and E3

Port Interface	Trunk or UNI
ATM Layer Protocol	LMI, ILMI
Port Alarm Processing	LOS, LOF
Connector	SMB

ATM Trunk Interface (BXM-155 Cards)

Line Rate	155.52 Mbps	
Line Code	NRZ	
Signal Level	Min dBm	Max dBm
MMF LED TX	-22	-15
MMF LED RX	-34	-10
SMF IR TX	-15	-8
SMF IR RX	-34	-10
SMF LR TX	-5	0
SMF LR RX	-34	-10
Framing Format:	STS-3c, STM-1	
Port Interface:	LMI, ILMI	
ATM Cell Rate:	353,208 cells/sec.	
Jitter:	ATM Forum UNI 3.1	
ATM Layer Protocol:	LMI, ILMI	
Port Alarm Processing:	LOS, LOF, LOP, Path AIS, Path Yellow	
Line Errors Counted:		
Connector:	SC for MMF, FC-PC for SMF (IR) and SMF (LR)	
Max. Cable Lengths:	MMF ~2 KM	
	SMF IR ~20 KM	
	SMF LR ~40 KM	
Indicators:	Card status, Port status.	

ATM Trunk Interface (BXM-622 Cards)

Line Rate	622.08 Mbps	
Line Code	NRZ	
Signal Level	Min dBm	Max dBm
SMF IR TX	-15	-8
SMF IR RX	-28	-8
SMF LR TX	-2	+2
SMF LR RX	-28	-8
Framing Format:	STS-12c, STM-4	
Port Interface:	LMI, ILMI	
ATM Cell Rate:	1,412,830 cells/sec.	
Jitter:	ATM Forum UNI 3.1	
ATM Layer Protocol:	LMI, ILMI	
Port Alarm Processing:	LOS, LOF, LOP, Path AIS, Path Yellow	
Line Errors Counted:		
Connector:	SMF-FC	
Max. Cable Lengths:	MMF ~2 KM	
	SMF IR ~20 KM	
	SMF LR ~40 KM	
Indicators:	Card status, Port status.	

ATM T3 Trunk Interface (BNI-T3, LM-3T3)

Line Rate:	44.736 Mbps 20 ppm, asynchronous.
Line Code:	B3ZS.
Signal Level:	DSX-3.
Framing Format:	C-bit parity is monitored. No other framing or control bits in the DS3 frame are either altered or monitored.
Protocol:	Physical Layer Convergence Protocol per AT&T Publication TA-TSY-000772 and 000773.
ATM Cell Rate:	96,000 cells/sec. Limited to 80,000 cells/sec. when interfacing with the IPX.
Alarms Sent:	AIS. Remote
Alarms Received:	AIS. Loss of Signal. Remote. Loss of Framing.
Line Errors Counted:	BPV. Parity Bit Errors.
Jitter:	Meets ACCUNET T45 specification (Pub 54014).
Connector:	75 ohm BNC.
Recommended Cable Lengths:	900 feet (275 m.) max. using specified cable. 450 feet (150 m.) to a DS3 crossconnect.
Indicators:	Card status. Port status.

ATM E3 Trunk Interface (BNI-E3, LM-3E3)

Line Rate:	34.368 Mbps 20 ppm, asynchronous.
Line Code:	HDB3.
Signal Level:	CCITT G.703.
Framing Format:	CCITT G.804, G.832.
Port Interface:	75 ohm unbalanced.
Barrier:	Fully barriered per EN 41003.
ATM Cell Rate:	80,000 cells/sec.
Jitter:	per CCITT G.823
ATM Layer Protocol:	per CCITT I.361 with HEC.
Port Alarm Processing:	AIS. Loss of Signal. Remote Alarm Indication. Loss of Framing.
Line Errors Counted:	BPV. Parity Bit Errors.
Connector:	75 ohm BNC.
Max. E3 Cable Lengths:	900 feet (275 m.) using specified cable.
Indicators:	Card status. Port status.

ATM OC3 Trunk Interface (BNI-OC3, LM-OC3)

Line Rate:	155.52 Mbps	
Line Code:	NRZ	
Signal Level:	Max	Min
MMF TX	-8 dBm	-15 dBm
MMF RX	-8 dBm	-28 dBm
SMF LR TX	0 dBm	-5 dBm
SMF LR RX	-10 dBm	-34 dBm
Framing Format:	STS-3c, STM1	
Port Interface:	LMI, ILMI	
ATM Cell Rate:	353,208 cells/sec.	
Jitter:	< 0.01 UI p-p, < 0.1 UI rms	
ATM Layer Protocol:	LMI, ILMI	
Port Alarm Processing:	LOS, LOF, LOP, Path AIS, Path Yellow	
Line Errors Counted:	Section BIP8, Line BIP24, Line FEBE, Path BIP8, Path FEBE	
Connector:	MMF SC SMF FC/PC	
Max. Cable Lengths:	MMF ~ 2 KM KM SMF IR ~20 KM SMF LR ~40 KM	
Indicators:	Card status. Port status.	

ATM Service Interface (BXM-T3/E3 Cards)

Capacity	8 or 12 ports per card.
Interface:	DS3/T3
Line Rate:	DS3 44.736 Mbs, E3 34.368 Mbps
No. of channels per card:	16,000
No. of channels per node:	
VPI Addressing Range:	ATM UNI 3.1 compliant
VCI Addressing Range:	ATM UNI 3.1 compliant
Queues:	16 COS with 32 Virtual Interface (VI) queues

ATM Service Interface (BXM-155 Cards)

Capacity	4 or 8 ports per card.
Interface:	OC-3c/STM-1
Line Rate:	155.52.08 Mbps
No. of channels per card:	16,000
No. of channels per node:	
VPI Addressing Range:	ATM UNI 3.1 compliant
VCI Addressing Range:	ATM UNI 3.1 compliant
Queues:	16 COS with 32 Virtual Interface (VI) queues

ATM Service Interface (BXM-622 Cards)

Capacity	2 ports per card.
Interface:	OC-12c/STM-4
Line Rate:	622.08 Mbps
No. of channels per card:	16,000/32,000
No. of channels per node:	
VPI Addressing Range:	ATM UNI 3.1 compliant
VCI Addressing Range:	ATM UNI 3.1 compliant
Queues:	16 COS with 32 Virtual Interface (VI) queues

ATM Service Interface (ASI-1, LM-2T3)

Capacity	2 ports per card.
Interface:	T3
Line Rate:	96,000 cells/sec.
No. of channels per card:	1000
No. of channels per node:	1000 or 5000 (grouped)
VPI Addressing Range:	0-255 (UNI), 0-1023 (NNI_7)
VCI Addressing Range:	1-4095
Queues:	32, 16 per line (port) includes CBR, VBR, and ABR queues.

ATM Service Interface (ASI-1, LM-2E3)

Capacity	2 ports per card.
Interface:	E3
Line Rate:	80,000 cells/sec.
No. of channels per card:	1000
No. of channels per node:	1000 or 5000 (grouped)
VPI Addressing Range:	0-255 (UNI), 0-1023 (NNI_
VCI Addressing Range:	1-4095
Queues:	32, 16 per line (port) includes CBR, VBR, and ABR queues.

ATM Service Interface (ASI-2, LM-OC3)

Capacity	2 ports per card.
Interface:	OC3
Line Rate:	353,208 cells/sec.
No. of channels per card:	1000
No. of channels per node:	1000 or 5000 (grouped)
VPI Addressing Range:	0-255 (UNI), 0-1023 (NNI_
VCI Addressing Range:	1-4095
Queues:	

BPX Cabling Summary

This appendix provides details on the cabling required to install the BPX node.

Note In all cable references, the transmit direction is from the BPX, receive is to the BPX.

Trunk Cabling

Trunk cables connect the customer DSX-3 crossconnect point or T3-E3 Interface Module to the BPX node at the LM-3T3 back card. Refer to Table B-1 for details.

Table B-1 Trunk Cables

Cable Parameter	Description
Type:	75-ohm coax cable (RG-59 B/U for short runs, AT&T 734A for longer runs). Two per T3/E3 line (XMT and RCV). For European shipment of the BXM-E3 cards, in order to meet CE mark transient test requirement (IEC1000-4-4), RG-17G double shielded SMB cable must be used.
Max. Length:	450 feet max. between the BPX and the DSX-3/E3 point.
Connector:	Terminated in male BNC; Rx is receive from trunk, Tx is transmit to trunk.

Power Cabling

Power connections are made to the AC Power Supply Shelf or the DC Power Entry Module at the rear of the BPX node. Refer to Table B-2 and Table B-3. (next page) for acceptable cable and wire types.

AC Powered Nodes

AC power cables may be provided by the customer or ordered from Cisco. Several standard cables are available (see Table B-2). AC cables with other plugs or different lengths may be special ordered. For users who wish to construct their own power cable, the cable must mate with an IEC320 16/20A male receptacle on rear of the AC Power Supply Assembly.

Table B-2 AC Power Cables

Cable Parameter	Description
Cable:	Provided with 8 feet (2.3 m.) of 3-conductor wire with plug.
Plug: customer end	20 A NEMA L620, 3-prong plug (domestic) or 13 A 250 Vac BS1363, 3-prong fused plug (UK, Ireland) CEE 7/7 (Continental Europe) AS3112 (Australia/New Zealand) CEI23-16/VII (Italy)

DC Powered Nodes

DC wiring (Table B-3) is generally provided by the customer.

Table B-3 DC Power Wiring

Cable Parameter	Description
Wiring:	Single conductor, 8 AWG recommended wire gauge, 75 C insulation rating, copper conductors only. Provision is provided for attaching conduit.
Connection:	90 ring lug for #10 screw terminal block.

LM-BCC Cabling

This cabling connects data ports on the LM-BCC to StrataView Plus NMS computers, control terminals, and modems. It is also used for external clock inputs from a clock source. See Appendix C, BPX Cabling Summary, for more details on peripherals that can be attached to these ports.

Auxiliary and Control Port Cabling

The auxiliary and control ports are used to connect one of the nodes in the network to a control terminal, StrataView NMS workstation, or modem connections for remote alarm reporting or system monitoring. Refer to Table B-4 and Table B-5 for details on this cable.

Table B-4 Auxiliary and Control Port Cabling

Cable Parameter	Description
Interface:	RS-232 DCE ports.
Suggested Cable:	24 AWG, 25-wire. A straight-through RS-232 cable is used for a terminal or printer connection. A null modem cable may be needed when interfacing with modems on either port.
Cable Connector:	DB-25, subminiature, male. Table B-5 contains a list of the port pin assignments.
Max. Cable Length:	50 feet (15 m.)

Table B-5 Auxiliary and Control Port Pin Assignments

Pin#	Name	Source	Description
1	FG	both	Frame Ground
2	TxD	DTE	Transmit Data
3	RxD	DCE	Receive Data
4	RTS	DTE	Request to Send
5	CTS	DCE	Clear to Send
6	DSR	DCE	Data Set Ready
7	SG	both	Signal Ground
8	CD	DCE	Carrier Detect
20	DTR	DTE	Data Term Ready

LAN Port Cabling

The LAN connection is used to connect one of the nodes in the network to a StrataView Plus NMS workstation. See Table B-6 and Table B-7 for details.

Table B-6 LAN Port Cabling

Cable Parameter	Description
Interface:	Ethernet DCE port.
Suggested Cable:	TBS
Cable Connector:	DB-15, subminiature, male. Table B-7 contains a list of the port pin assignments.
Max. Cable Length:	50 feet (15 m.) max. to interface adapter.

Table B-7 LAN Port Pin Assignments

Pin #	Name	Pin #	Name
1	Shield	---	---
2	Collision Presence +	9	Collision Presence -
3	XMT +	10	XMT -
4	Reserved	11	Reserved
5	RCV +	12	RCV -
6	Power return	13	Power (+12V)
7	Reserved	14	Reserved
8	Reserved	15	Reserved

Modem Cabling

Refer to Appendix C, BPX Peripherals Specifications, for modem cabling information.

External Clock Input Cabling

This cabling is for making external clock connections for use by the BCC-32, BCC-3, and BCC-4 backcards. The BCC-32 uses the BCC-bc backcard, and the BCC-3 and BCC-4 both use the BCC-3-bc backcard.

T1 Clock Cabling

Table B-8 through Table B-11 provide details for T1 clock cabling.

Table B-8 External Clock Cabling

Cable Parameter	Description
Cable Type:	22 AWG, ABAM individually shielded twisted pair. Two pair per T1 line (1 transmit and 1 receive).
Cable Connector:	Male DB-15 subminiature. See Table B-10 through Table B-11 for pinouts.
Max. Cable Length:	533 ft (162 m.) maximum between the BPX and the first repeater or CSU. Selection of cable length equalizers.

Table B-9 T1 Connection to XFER TMG on BCC-bc

Pin #	Description
1	Transfer timing ring
2	Transfer timing tip
3 & 4	Transfer timing shield

Table B-10 T1 Connection to EXT TMG on BCC-bc

Pin #	Description
2	Receive pair shield
3	Receive tip
11	Receive Ring

Table B-11 T1 Connection to EXT 1 or EXT 2 on BCC-3-bc

Pin #	Description	Function
1	Transmit tip	Transmit T1 timing signal synchronized to the node
2	Transmit pair shield	
3	Receive tip	Receive clock for synchronized clock source for node
4	Receive pair shield	
7	Transfer timing tip	
8	Transfer timing shield	
9	Transmit ring	
11	Receive ring	
15	Transfer timing ring	

E1 Clock Cabling

Table B-12 through Table B-15 provide details for E1 clock cabling.

Table B-12 E1 Connector Pin Assignments for External Clock

Connector	Description
Cable Type:	75-ohm coax cable for unbalanced connection or 100–120-ohm twisted pair for balanced connection. Two cables/pairs (1 transmit, 1 receive) per E1 line.
Cable Connector:	Two female BNC for unbalanced connection; male DB15 for balanced connection. See Table B-13 and Table B-15 for pinouts.
Max. Cable Length:	Approx. 100 meters maximum between the BPX and the first repeater or CSU. Equalizer for cable length.

Table B-13 E1 Connection 75 Ohm to EXT TMG on BCC-bc or BCC-3-bc

Connector	Description
BNC	Receive E1 from trunk

Table B-14 E1 Connection 100/120 Ohm to EXT TMG on BCC-bc

Pin #	Description
2	Receive pair shield
3	Receive tip
11	Receive Ring

Table B-15 E1 Connection 100/120 Ohm to EXT 1 or EXT 2 on BCC-3-bc

Pin #	Description	Function
1	Transmit tip	Transmit T1 timing signal synchronized to the node
2	Transmit pair shield	
3	Receive tip	Receive clock for synchronized clock source for node
4	Receive pair shield	
7	Transfer timing tip	
8	Transfer timing shield	
9	Transmit ring	
11	Receive ring	
15	Transfer timing ring	

External Alarm Cabling

This cable (Table B-16) is for connecting network alarm outputs to the LM-ASM ALARM OUTPUT connector only. Table B-17 lists the pinouts for the network alarm outputs.

Table B-16 External Alarm Cabling

Cable Parameter	Description
Interface:	Dry-contact relay closure.
Wire:	24 AWG, shielded, 6-pair.
Connector:	DB-15, Subminiature, male

Table B-17 Network Alarm Pin Assignments

Pin	Alarm	Description
1	Audible—Major	Normally open
2		Common
9		Normally closed
4	Visual—Major	Normally open
5		Common
12		Normally closed
7	unused	n.c.
8	unused	n.c.
3	Audible—Minor	Normally open
11		Common
10		Normally closed
6	Visual—Minor	Normally open
14		Common
13		Normally closed
15	unused	n.c.

Standard BPX Cables

Table B-18 lists the various cables that may be ordered directly from Cisco. Cable lengths are specified as a suffix to the Cisco model number. For example 5610-50 indicates a 50 foot cable. Cables are generally available in standard lengths of 10 ft (3 m.), 25 ft (7.6 m.), 50 ft (15 m.), 75 ft (22.8 m.) and 100 ft (30 m.) Lengths of 101 ft. (30 m.) to 600 ft. (183 m.) are available on a special order.

When a cable is connectorized, the connector gender (male-female) will be indicated as well as the number of pins. For example RS-232/M25-M25 indicates a cable terminated with a male DB25 at both ends.

Table B-18 Standard Cables

Model#	Description	Usage
T3-E3-10	75 coax/BNC-BNC, 10'	T3 or E3 trunk interface
T3-E3-25	75 coax/BNC-BNC, 25'	
T3-E3-50	75 coax/BNC-BNC, 50'	
T3-E3-75	75 coax/BNC-BNC, 75'	
T3-E3-xx	length to be specified	
5620	RS-232/M25-F25	Control port to control terminal, StrataView, or ext. window device
5621	RS-232/M25-M25 special	Control or Aux. port to modem
5623	RS-232/M25-M25	Aux. port to ext. window device
5601	Ground cable	DC
5670	Molex-pigtail	DC
5671	Spade lug-pigtail	DC

Redundancy “Y” Cable

The redundancy cables are a special “Y” cable available from Cisco. They are required for redundant trunk and data interfaces. Table B-19 lists the Y-cables used with various BPX back cards.

Table B-19 Redundancy Y-Cables

Y - Cable	Used On	Cisco P/N
T3 trunk	LM-3T3	TBS
E3 trunk	LM-3E3	TBS
Aux./Cont. ports	LM-BCC	TBS
Ext. Clk. In	LM-BCC	TBS
Ext. Clk. Out	LM-BCC	TBS

BPX Peripherals Specifications

This appendix provide details on BPX peripheral equipment, including printers and modems. The appendix includes the following sections:

- Network Management
- Printer
- Modems, Dial-In and Dial-Out

Network Management

StrataView Plus Terminal

A StrataView Plus workstation is recommended for managing a network containing IPX, IGX, and BPX nodes. Refer to the *StrataView Plus Operation Manual* and *StrataView Plus Installation Manual* for setup instructions and specifications for the StrataView Plus NMS, which is required to provide network alarm, control, and statistics monitoring.

Note For network management, a StrataView Plus workstation is connected to the LAN port of one or more network nodes, typically BPX nodes because of their processing power, to provide network management.

Control Port, Local Control

A terminal (pc or workstation, including a StrataView Plus workstation) can be connected to the CONTROL port of a BPX for temporary or local control. This can be especially useful during installation, initial power-up, and configuration. Refer to Table C-1 for configuration data for the BPX CONTROL port.

Table C-1 Control Port Parameters for Local Control (pc or workstation)

Parameter	Setting
BPX Port Used:	Serial CONTROL port, located on a BCC back card, is used to interface to a local terminal.
Code:	Standard 7 or 8-bit ASCII; 1 or 2 stop-bits; even, odd or no parity.
Interface:	RS-232 DCE.
Data Rate:	All standard asynchronous data rates from 300 to 19200 bps, independently software-selectable.
Supported Terminals:	Any terminal compatible with DEC VT-100.
Cable Required:	Straight-through RS-232 cable.

Printer

The standard maintenance printer that is currently being shipped with the BPX is the Okidata Model 184 dot matrix printer. This printer may be connected to any node. Refer to Table C-2 and Table C-3 for printer configuration requirements. Note that this is not the same as the printer that may be provided with the StrataView Plus NMS terminal but in addition to it.

Table C-2 Auxiliary Port Parameters for OkiData 184 Printer

Parameter	Setting
BPX Port Used:	Serial AUXILIARY port, located on the LM-BCC card, is used for the maintenance printer.
Code:	Standard 8-bit ASCII; 8 data bits, 1 stop-bit, odd parity.
Interface:	RS-232 DCE.
Data Rate:	9600 baud.
Supported Printer:	Okidata 184.
Cable Required:	Straight-through RS-232 cable

DIP Switch Settings for Okidata 184

DIP Switch A is an 8-section DIP switch located on the printer's main circuit board. Access to the configuration switches is made by sliding back the switch cover at the top, rear of the printer case. Set Switch A as indicated in Table C-3.

Table C-3 **Switch A Settings—Okidata 184 Printer**

Switch A	Setting	Description
1	Off	ASCII with non-slashed zero
2	Off	ASCII with non-slashed zero
3	Off	ASCII with non-slashed zero
4	Off	11-inch paper length
5	On	11-inch paper length
6	Off	No Auto Line Feed.
7	On	8- bit data.
8	Off	Enables front panel.

The High Speed Serial Interface DIP Switch consists of two DIP switches, SW1 and SW2, located on a serial-board that is attached to the printer's main board. Set switches 1 and 2 as indicated in Table C-4 and Table C-5.

Table C-4 Switch 1 Settings—Okidata 184 Printer

Switch 1	Setting	Description
1	On	Odd parity.
2	On	No parity.
3	On	8 data bits.
4	On	Ready/busy protocol.
5	On	Test select circuit.
6	On	Print mode.
7	On	Busy line selection.
8	On	DTR pin 2 enabled.

Table C-5 Switch 2 Settings—Okidata 184 Printer

Switch 2	Setting	Description
1	Off	Transmission
2	On	Speed = 9600 baud.
3	On	Speed = 9600 baud.
4	On	DSR active.
5	On	Buffer = 32 bytes.
6	On	Timing = 200 ms.
7	On	Space after power on.
8	Don't care	Not used.

Modems, Dial-In and Dial-Out

Customer service uses modems for diagnosing and correcting customer problems with installed BPX systems. The modem that is currently recommended for use with the BPX is the Codex Model V.34R.

A dial-in connection to a BPX RS-232 from customer service via a modem uses the CONTROL port of the BPX. A dial-out connection from a BPX via a modem to customer service uses the AUXILIARY port of the BPX. Refer to Table C-6 for interface requirements.

Table C-6 Modem Interface Requirements

Parameter	Requirement
BPX Port Used:	CONTROL port on BCC back card is used for auto-answer modem setup. AUXILIARY port on a BCC back card is used for auto-dial modem setup.
Code:	Standard 8-bit ASCII, 1 stop-bit, no parity.
Interface:	RS-232 DCE.
Cable to modem:	Null modem cable: CONTROL or AUXILIARY port to modem (DCE to DCE)
Phone Lines:	Dedicated, dial-up business telephone line for Customer Service-to-BPX modem.
Data Rate:	All standard asynchronous data rates from 300 to 19200 bps, independently software-selectable.
Supported Modems:	Motorola V.34R 28.8 baud modem with or without talk/data button.

Motorola V.34R BPX Dial-In Configuration

BPX Auto-Answer (Dial-In to BPX)

The following is a setup procedure that allows customer service to dial in to the customer's BPX to provide support and troubleshooting:

- Step 1** Using the **cnfterm** command, set the BPX CONTROL port speed to 9600 bps.
- Step 2** Using the **cnftermfunc** command, set the terminal type to VT100/StrataView.
- Step 3** To program the modem, temporarily attach a terminal to the modem using a straight through RS-232 cable (DTE to DCE). The modem EIA port will automatically match the 9600 bps setting of the terminal.
- Step 4** Enter the commands listed in Table C-7, to set up the modem for proper operation.

Note Consult the manual that is supplied with your modem for specific information concerning the modem configuration. Call customer service for latest modem configuration information.

- Step 5** Disconnect the terminal and the straight-through cable from the BPX CONTROL port.

Step 6 Connect the modem to the BPX CONTROL port using a null-modem cables (Figure C-1). A null modem cable is used, as the connection is essentially a DCE to DCE rather than a DTE to DCE connection.

Step 7 Ask customer service to assist in testing the operation of the modem setup.

Table C-7 V.34R Modem Configuration for Auto-Answer (Dial-in to BPX)

Step	Command	Function
1.	AT & F	Reset to factory default.
2	ATL1	Set modem loudness, modem speaker at low volume.
3.	ATSØ=1	Enables Auto-Answer Mode on modem (answer on first ring).
4	AT\N3	Enables automatic MNP error correction.
5	AT%C	Disables data compression.
6.	AT\QØ	Disables XON/XOFF flow control.
7.	AT&S1	Sets DSR to "normal".
8.	ATEØ	Disables local character echo. Modem will not echo what you type.
9.	ATQ1	Disables result codes. (Modem will appear "dead", will stop responding "OK" to commands.)
10.	AT&W	Saves current configuration settings in non-volatile memory. (Writes and stores to configuration location 1.)

Figure C-1 Dial-Modem Cabling for Auto Answer (Dial-In to BPX)

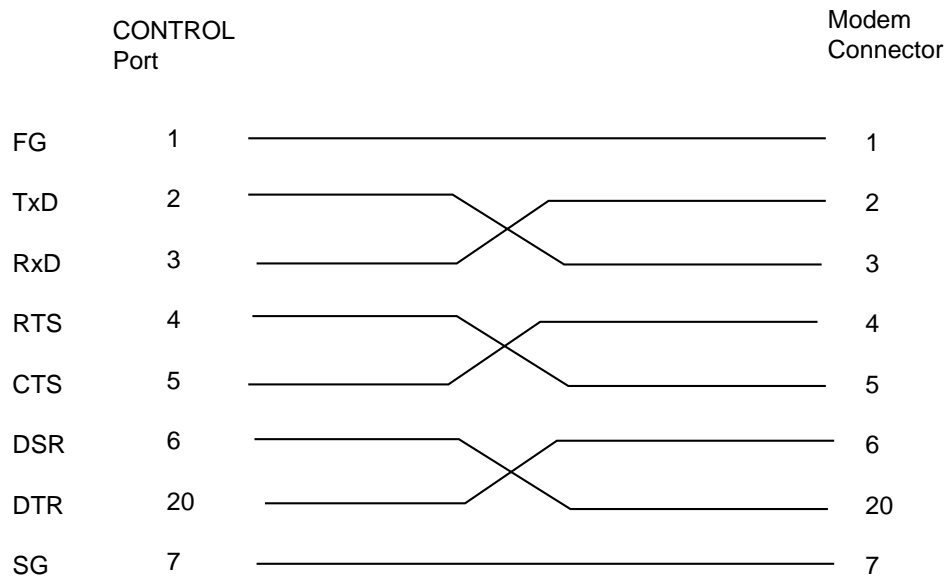

LEGEND:

- FG - Frame ground
- TxD - Transmit data
- RxD - Receive data
- RTS - Request to send
- CTS - Clear to send
- DSR - Data set ready
- DTR - Data Terminal Ready
- CD - Carrier Detect
- SG - Signal Ground

z1000

IPX Auto-Dial to Customer Service

The following is a setup procedure for the customer's BPX to dial up customer service.

- Step 1** Using the **cnfterm** command, set the BPX AUXILIARY port speed to 9600 bps and enable XON/XOFF flow control.
- Step 2** Using the **cnftermfunc** command, select option 7, "Autodial Modem" and enter the customer service-designated Network ID, and the customer service modem phone number.
- Step 3** Attach a 9600 bps terminal to the modem using a straight-through cable. The modem EIA port will automatically match the 9600 bps setting of the terminal.
- Step 4** Enter the commands listed in either Table C-8 (V.34R modem without talk/data pushbutton) or Table C-9 (V.34R modem with talk/data pushbutton), to set up the modem for proper operation.

Note Consult the manual that is supplied with your modem for specific information concerning the modem configuration. Call customer service for latest modem configuration information.

Step 5 Disconnect the terminal and the straight-through cable from the IPX CONTROL port.

Step 6 Connect the modem to the IPX AUX port using a null modem cable Figure C-2.

Step 7 Ask customer service to assist in testing the operation of the modem setup.

Table C-8 V.34R Auto-Dial Configuration (dial-out to customer service)*

Step	Command	Function
These configuration commands are for a V.34R modem that does not have a talk/data pushbutton.		
1.	AT&F	Initializes factory defaults.
2.	ATL1	Modem speaker at minimum volume.
3.	AT*SM3	Enables automatic MNP error correction.
4.	AT*DC0	Disables data compression.
5.	AT*SC1	Enables DTE speed conversion
6.	AT*FL1	Enables XON/XOFF flow control.
7.	AT*SI1	Enables 5-minute inactivity disconnect.
8.	AT&C1	DCD controlled by modem.
9.	AT&D2	Modem disconnects when IPX toggles DTR.
10.	AT&V	Verify entries.
11.	AT&W	Saves current settings to non-volatile memory.

Table C-9 V.34R with talk/data, Auto-Dial Configuration (dial-out to customer service)*

Step	Command	Function
These configuration commands are for a V.34R modem that has a talk/data pushbutton.		
1.	AT&F	Initializes factory defaults.
2.	ATL1	Modem speaker at minimum volume.
3.	AT\N3	To enable MNP error correction
4.	AT%C	To disable data compression
5.	AT\J	Enables DTE speed conversion
6.	AT\Q1	Enables flow control
7.	AT\T3	Enables 3-minute inactivity timer
8.	AT&C1	DCD controlled by modem.
9.	AT&D2	Modem disconnects when IPX toggles DTR.
10.	AT&V	Verify entries. (<i>shows current configuration</i>)
11.	AT&W	Saves current settings to non-volatile memory.

Figure C-2 Dial Modem Cabling for Auto Dial (dial-out to customer service)

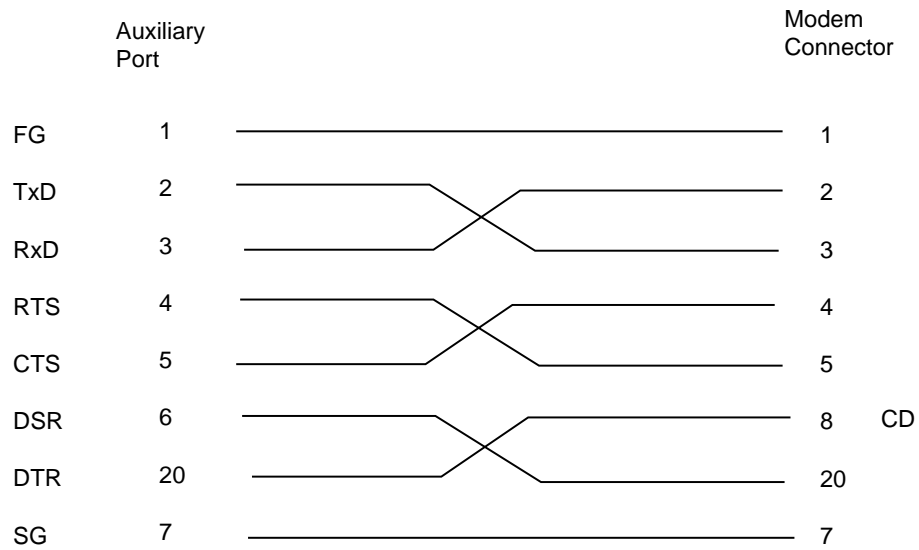

Note: Cable must be connected in direction shown from node to modem because wiring is not pin-to-pin symmetrical.

LEGEND:

- FG - Frame ground
- TxD - Transmit data
- RxD - Receive data
- RTS - Request to send
- CTS - Clear to send
- DSR - Data set ready
- DTR - Data Terminal Ready
- CD - Carrier Detect
- SG - Signal Ground

z1001

AT3-6ME Interface Adapter

This Appendix describes the AT3-6ME Interface Adapter, sometimes referred to as the T3-T2 Interface Adapter, that is used with the BPX to provide a 6 Mbps ATM network interface to T2 transmission facilities.

Application

The AT3-6ME Interface Adapter is used with the BPX Broadband ATM Switch or the IPX Narrowband Switch in applications where it is required to interface a 6 Mbps T2 digital network facility to the 45 Mbps T3 ATM port on the BPX or IPX node.

Applications include users where T2 transmission facilities are available. And also for users with ATM networks who require somewhat more bandwidth than is provided by the T1 or E1 ATM network connections but do not need the full T3 bandwidth provided by the BPX ATM network ports. See Figure D-1 for a typical application.

Figure D-1 **Network Application**



General Description

The AT3-6ME Interface Adapter is a bi-directional device which provides a conversion between transmission systems of different transmission rates, the North American T3 (44.736 Mbps) and the Japanese 6M (T2). It is used only in ATM networks. The adapter is transparent to the both users and the network.

The T3 interface operates at 44.736 Mbps with the B-ISDN Physical Layer Convergence Protocol (PLCP) and meeting the ATM Forum standards. The T2 interface operates at 6 Mbps according to the Japanese Nippon Telephone & Telegraph (NTT) User-Network Interface (UNI) specifications.

ATM cells from one interface are mapped to the other interface enabling users with ATM node equipment with North American T3 ATM ports to operate in a T2 network. The ATM cell throughput on a T2 digital trunk using this adapter is limited to 14,490 cells per second.

The cell transfer rate for T2 is greatly reduced from the T3 cell rate out of a T3 port on an IPX using the ATMT card or from a BPX port. Therefore it is very important to restrict the cell rate from the node when using a T2 trunk. Cell rate adaptation is done via software trunk configuration at the T3 ATM interface, where the non null cell throughput is limited to the T2 capacity. In the T2 to the T3 direction, the T3 ATM interface has more than enough capacity to accommodate the T2 cell rate.

The Interface Adapter can buffer a 70-cell burst at the T3 rate before the T2 interface will begin to drop cells. Cells will continue to be dropped until the T3 interface returns to a rate that complies with the bandwidth of the T2 interface.

All alarms and line errors are passed through the Interface Adapter unchanged. Any existing network management system has an instant view of the actual network transmission system. Errors at the ATM layer propagate through from one interface to the other, thus the end user has the complete knowledge and statistical information regarding the network status at all times. Therefore a special network management interface is not required.

Since the T3 interface is asynchronous and the T2 is synchronous, the AT3-6ME can be configured to carry the synchronization information through from one interface to the other. The synchronization is carried through the T3 interface using the PLCP-embedded 8 KHz. The T2 interface clock may be generated locally or it may be slaved to the public network.

Equipment Description

The AT3-6ME is fully contained in a metallic housing designed to be mounted in a 19" equipment rack. It occupies only one rack mounting space and is powered from normal AC line powering. The power supply accommodates an input voltage over the range 90 to 240 VAC, 50 or 60 Hz.

Interface Connectors

The interface connectors are located on the rear panel (Table D-1 and Figure D-2). These connectors include:

- Two T3 BNC connectors, XMT and RCV.
- Two 6M BNC connectors, XMT and RCV.
- A single RS-232 male, subminiature 9-pin control terminal interface.
- AC input connector with integral fuse.

The control terminal is a standard RS-232 interface DTE interface. No hardware handshake is required for the interface. The diagnostic display comes up immediately. It operates at 9.6 Kbps with any ASCII terminal.

Table D-1 Rear Panel Connectors

Connector	Type	Description
T3 RX	BNC	Receive T3 input from BPX or IPX ATM port.
T3 TX	BNC	Transmit T3 output to BPX or IPX ATM port.
T2 RX	BNC	Receive 6 MB input from T2 facility.
T2 TX	BNC	Transmit 6 MB input to T2 facility.
RS-232	DB9	Control terminal connection.
Primary Power	IEC	AC power input with fuse.

Front Panel Indicators

The front panel of the system provides LED indicators for the alarm status of the transmit and the receive T3 and the T2 interfaces (refer to Table D-2 and Figure D-2). Also on the front panel are indications for power and for operating status (Fail/Active).

The Overflow LED indicates that the cell rate coming from the T3 interface exceeds the bandwidth of the T2 facility and that the Interface Adapter buffer has overflowed.

Table D-2 Front Panel Indicators

Indicator	Color	Description
T3 Receive Status—AIS	Green	Alarm Indication signal detected on the RCV T3 line.
T3 Receive Status—RAI	Yellow	Remote Alarm Indication signal detected on the receive T3 line.
T3 Receive Status—LOS	Red	Loss of receive T3 signal
T3 Receive—LOF	Red	Loss of frame on receive T3 signal
T3 Transmit Status—AIS	Green	Alarm Indication signal detected on the transmit T3 line.
T3 Transmit Status—RAI	Yellow	Remote Alarm Indication signal detected on the transmit T3 line.
T3 Transmit Status—LOS	Red	Loss of transmit T3 signal
T2 Receive Status—AIS	Green	Alarm Indication signal detected on the RCV T2 line.
T2 Receive Status—RAI	Yellow	Remote Alarm Indication signal detected on the receive T2 line.
T2 Receive Status—LOS	Red	Loss of receive T2 signal
T2 Receive—LOF	Red	Loss of frame on receive T2 signal
T2 Transmit Status—AIS	Green	Remote Alarm Indication signal detected on the transmit T2 line.
T2 Transmit Status—RAI	Yellow	Loss of transmit T2 signal
T2 Transmit Status—LOS	Red	Loss of frame on transmit signal
Overflow	Red	T3 receive cell rate exceeds the T2 line capacity.
FT2	Red	Fractional T2 indication for future use.
T3/T2 loop	Red	Indicates the unit is in loop back mode, external toward the T3 and T2 line interfaces.
Active/Fail	Green/Red	Upon power up the system will go through extensive self tests. If self-test passes, the Active /Fail LED will be green; if self-test fails the LED will be RED.
Power	Green	Power ON indication.

DIP Switches

The adapter has two front panel DIP switches, a two-position (SW-1) and a 12-position (SW-2) switch. SW-1 controls the configurations that may interrupt operation and should be done through a two-step operation. SW-2 enables all other configuration parameters.

Figure D-2 Front and Rear Panel Features

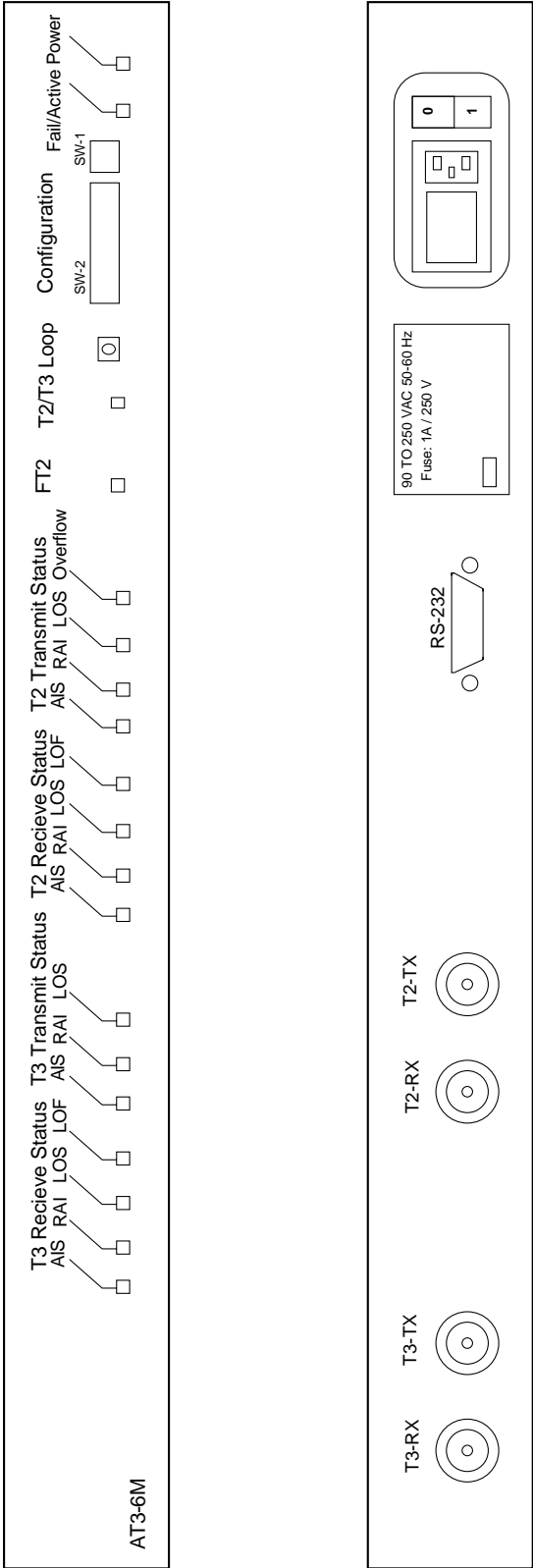

Installation

Install the AT3-6ME in a rack adjacent to the BPX enclosure (allowing room for any AC Power Supply Assembly that may also need to be mounted) or in the IPX enclosure wherever there is space for the AT3-6ME adapter.

System Connections

Two short BNC-BNC cables are required to connect the AT3-6ME to the BPX or IPX node.

- Step 1** For use with BPX, connect one cable between one of the three TX connectors on a selected BPX LM-3T3 card and the T3-RX connector on the AT3-6ME back panel. For IPX applications, connect to the TX connector on the ATMT back card
- Step 2** Connect the other cable between the associated RX connector on the BPX LM-3T3 or ATMT card and the T3-TX connector on the AT3-6ME back panel.
- Step 3** Connect the cable coming from the 6 Mbps facility to the T2-RX connector on the AT3-6ME.
- Step 4** Connect the cable going to the 6 Mbps facility to the T2-TX connector on the AT3-6ME.
- Step 5** Connect the AC power cord to the IEC connector on the rear of the AT3-6ME.

AT3-6ME Configuration

The adapter configuration is done via a set of DIP switches located on the front panel. There are two sets of switches, a 12-position switch and a two position switch. The two position switch enables the configuration change via the terminal and enable/disable the loop push button located in the front panel (to secure against accidental operation). Review both Table D-3 and Table D-4. Set the appropriate DIP switches with the power off.

Table D-3 DIP Switch SW-1 Selection Guide

Switch	Position	Function
1	Down	Enable configuration via the TTY.
1	Up	Disable configuration via the TTY (default).
2	Down	Enable front panel loop push button.
2	Up	Disable front panel loop push button (default).

Table D-4 DIP Switch SW-2 Selection Guide

Switches	Position	Function
1	Up	Internal synchronization source for the T2 transmitter.
2	Up	
1	Up	Slave T2 transmitter to T3 line
2	Down	
1	Down	Slave T2 transmitter to T2 receiver
2	Down	
3	Up	Long length T3 cable.
4	Up	
3	Up	Medium length T3 cable.
4	Down	
3	Down	Short length T3 cable; system is co located to IPX/BPX ¹ (default).
4	Down	
5, 6	don't care	Unused
7	Up	ATM converter mode
7	Down	Test Mode
8	Up	Enable BPV relay from T2 to T3
8	Down	Disable PV relay from T2 to T3
9	Up	Long length T2 cable
9	Down	Short length T2 cable (default). ¹
10, 11, 12	don't care	Unused

1. T2 and T3 cable length should be set to "short" upon power-up for self-test.

Upon LOS, defaults to "internal synchronization."

BPX or IPX Port Configuration

The trunk on the BPX or IPX node must be reconfigured from StrataView Plus or a local control terminal.

- Step 1** Telnet to the first node equipped with an AT3-6ME.
- Step 2** Use the Configure Trunk (**cnftrk**) command to select T2 for the Tx Trunk Rate.
- Step 3** Set the RCV Trunk Rate to 28980 cps.
- Step 4** Repeat steps 1 through 3 for all other nodes using the AT3-6ME.

Operation

The following paragraphs describe the various operating modes for the AT3-6ME. The unit is basically designed for unattended operation. Any failures in the unit or any line alarms or errors will be propagated.

Power-Up Sequence

During the system power-up, the unit goes through a self test procedure. The Power LED turns green, the Active/ Fail LED stays off until the self test sequence is completed. At the end of the self test the loop LED comes on for about 5 seconds.

Through the self test, all LEDs light up. When the test is completed successfully the Active/Fail LED turns green. If the system fails self test, it will repeat the self-test twice more. If it continues to fail, the Active/Fail LED turns red.

Normal Operation

In standard operation the AT3-6ME system relays ATM cells from the T2 6M to the T3 interface. To accommodate for the difference in the transmission rate, the AT3-6ME removes all null cells from the T3 interface. The T3 sources connected to the AT3-6ME must regulate their ATM Cell rate not to exceed the T2 6M cell rate. The AT3-6ME can absorb up to 70 cells in a single burst.

The AT3-6ME Interface Adapter can interface to any ATM UNI or NNI line at the T2 or T3 rate. The AT3-6ME Relays alarms and errors from one interface to the other. It relays the alarm and error conditions as indicated in Table D-5.

Table D-5 Alarm Handling

Alarms Passed Thru (both directions)	Errors Relayed Thru (both directions)
AIS	HEC Error—both directions.
RAI	BPV (up to 10^{-5} rate)—6M to T3 only.
LOS	
LOF	

Remote Loop Operation

The AT3-6ME has the capability of creating a remote loop on both the T3 and the T2 sides for test purposes. The loop can be activated by manually pressing a front-panel switch or through the control terminal. The loopbacks are through looping relays at the two interfaces and they operate simultaneously.

To activate the loop from the front panel, one must first enable the proper DIP switch on SW-1. Then press and hold the front panel push button for one second. This is to prevent accidental operation of the loop. Once the loop is set it can be removed by operating the loop switch a second time or it will automatically remove itself after one hour.

Terminal Operation

The system is designed to operate without a terminal. However there is a terminal interface designed for diagnostics and maintenance purpose only. The terminal interface is always active and continuously displays the user prompt. The terminal interface operating parameters are as follows:

- a. Electrical Interface: RS232
- b. DTE/DCE: DCE
- c. Speed: 9.6 Kbps
- d. Handshake: NON
- e. Connector: Male DB9

Upon power up, the system goes through power up diagnostics. The terminal displays the diagnostics sequence. Upon successful self test the unit is available for operation. The terminal will display the actual set up of the system represented by the DIP switches (Table D-6). If the configuration was overwritten through the TTY, the terminal will display the actual set up that could be different then the dip switch setting.

Table D-6 DIP Switch Settings

1	2	3	4	5	6	7	8	9	10	11	12	1	2
0/1	0/1	0/1	0/1	0/1	0/1	0/1	0/1	0/1	0/1	0/1	0/1	0/1	0/1

Commands

Commands are entered after the user prompt. Commands are available to display the various error counters and alarms associated with the T2 line and the T3 port interface, select the source of timing for the DSU, and to enable and remove the remote loop. Table D-7 lists available commands for use with the AT3-6ME terminal interface while Table D-8 indicates the display format.

Table D-7 Command Summary

Command	Parameters	Meaning
?		Help Menu
dspstat		Display status. See Figure D-2 for display.
dspstat clear		Clears the status display
Override dipsw	0 1	Disable TTY configuration entry. Enable TTY configuration entry. Operates only when DIP switch 1-1 is down.
Sync source	0 1 2	System is slaved to the 6M line System is slaved to the T3 line System runs of its internal clock
Remote loop	# of seconds stop	Enable remote loop back operation. Cancel the loop back operation.

Table D-8 Status Display

Status	T3¹	T2¹
BPV	NNN	NNN
Parity Errors	NNN	X
Framing Errors	NNN	NNN
PLCP Framing Errors	NNN	X
HEC Errors	NNN	NNN
RX Cells	NNN	NNN
TX Cells	NNN	NNN
AIS	1/0	1/0
1/0	1/0	1/0
LOF	1/0	1/0
Overflow	X	1/0

1. X = not available

Specifications

The following are the specifications for the AT3-6ME Interface Adapter.

T3 interface

Line rate:	44.736 Mbps 20 ppm.
Framing format:	C-bit parity
Line code:	B3ZS
Physical layer:	PLCP format.
ATM layer:	UNI per the ATM Forum UNI 3.0 specification.
Cell Rate:	Up to 96,000 cells/sec.
Connector:	75 ohm BNC

T2 Interface

Line rate:	6.312 Mbps
Line code:	B8ZS
Synchronization:	Internal 6.312 Mbps 30 ppm or Slave to the incoming 6 Mbps line or Slave to the T3 PLCP frame.
Framing format:	ITU-T G.703
ATM Layer:	Per NTT UNI specification dated 1993.
Queue:	75 cell FIFO.
Cell Rate:	Up to 14,490 cells/sec.
Connector:	75 ohm BNC.

Power

Input Power:	90 VAC to 250 VAC, 50/60 Hz.
Power consumption:	30 watts
Input Power Connector:	Universal power entry module with fuse.
Fuse size:	1/2A 250 VAC

Mechanical

Rack Mounting Space:	1 rack mount space, 19" rack.
Size:	19" x 1.75" x 8.5"

Terminal Interface

Speed:	9.6 Kbps
Type:	DTE
Handshake:	NONE
Connector:	DB9

Glossary

A

A-bit (active bit)

The bit in the frame relay frame header that indicates the status of the far end user device and the status of the PVC segment in the foreign network.

A-law

An analog to digital encoding scheme used to convert voice samples to an 8-bit data word used in CEPT E1 multiplex equipment. (See also *-law*.)

ABR (Available Bit Rate)

ATM connection type for bursty traffic, such as data. Provides closed loop control of service rate that allows connections to use additional bandwidth when available. ABR may be used with ATM Traffic Management 4.0 standards VSVD flow congestion control, or with the proprietary ForeSight flow congestion control. See also, CBR and VBR.

ACO (Alarm Cut Off)

A switch to turn off the audible alarm outputs from a node while leaving the visual alarm outputs unchanged.

adaptive voice

An optional feature of the IPX that disables VAD from connections using it whenever there is excess bandwidth available to allow the normal encoded voice to be carried on the packet line. See also VAD.

ADPCM (Adaptive Differential Pulse Code Modulation)

A compression method that samples voice 8,000 times per second, and uses the changes between samples as the basis for compression. Increases the capacity of a T1 line from 24 to 48 channels.

ADTF (Allowed Cell Rate Decrease Factor)

Time permitted between sending RM cells before the rate is decreased to ICR.

AIT (ATM Interworking Trunk Card)

The AIT front card provides an ATM trunk interface for the IPX. The AIT operates in conjunction with a backcard, AIT-T3 or AIT-E3.

AIT-E3 (ATM Interworking Trunk E3 Interface Card)

The AIT-E3 backcard provides an E3 interface for the AIT (IPX) or BTM (IGX) ATM trunk cards.

AIT-T3 (ATM Interworking Trunk T3 Interface Card)

The AIT-T3 backcard provides a T3 interface for the AIT (IPX) or BTM (IGX) ATM

alternate routing

An automatic rerouting of a failed connection by a node to a new route through the network to maintain service.

AMI (Alternate Mark Inversion)

The line code used for T1 and E1 lines where the “1s” or “marks” on the line alternate between positive polarity and negative polarity.

arbiter

A BPX administration processor that polls each network port to control the data flow in and out of the crosspoint switch matrix.

ARC (Alarm Relay Card)

An alarm front card for the IPX.

ARI (Alarm Relay Interface Card)

An alarm interface back card for the IPX and IGX.

ARM (Alarm Relay Module)

An alarm front card for the IGX.

ASM (Alarm/Status Monitor Cards)

An alarm front card and back card set for the BPX.

ATM (Asynchronous Transfer Mode)

Data transmission that uses a very flexible method of carrying information, including voice, data, multimedia, and video between devices on a local or wide area network using 53-byte cells on virtual circuits. The 53 byte cell consists of data and a small header. See also cell relay.

ATM Switched Virtual Circuits (SVCs)

A member of the INS product family that uses ATM SVC Server Shelves and software to enhance a StrataCom network with ATM switched virtual circuits.

ATM SVC Server Shelf

An adjunct processor used in the INS ATM SVC application to enhance traditional StrataCom networks with ATM switched virtual circuits. The ATM SVC Server Shelf is co-located with and connected to a BPX.

auxiliary port

An RS-232 port on the front panel of the SCC card used for connecting a printer or an out-dial modem. This port is a one-way, outgoing port.

B**B3ZS (Bipolar with Three Zero Suppression)**

A protocol for T3 lines that converts a channel word with three consecutive zeros into a code which, at the far end, is converted back to three zeros.

B8ZS (Bipolar with Eight Zero Suppression).

A T1 line protocol that converts a channel word with eight consecutive zeros into a code which, at the far end, is converted back to eight zeros. Allows 64 Kbps clear channel operation while assuring the ones density required on the T1 line.

bandwidth reservation

An IPX software feature that allows circuits to automatically become active (or “upped”) at a specified time and date and downed at some later time and date. For circuits that do not need to be available 100% of the time.

B channel

In ISDN, a full-duplex, 64-kbps channel used to send user data. Also known as the bearer channel. Compare with D channel.

BCC

The control card for the BPX

BC-E1 (Backcard E1)

E1 interface card used on IPX and IGX

BC-E3 (Backcard E3)

E3 interface card used on IPX and IGX

BC-J1 (Backcard J1)

J1 interface card used on IPX and IGX

BC-SR (Backcard Subrate)

Subrate interface card used on IPX and IGX

BC-T1 (Backcard T1)

T1 interface card used on IPX and IGX

BC-T3 (Backcard T3)

T3 interface card used on IPX and IGX

BC-Y1 (Backcard Y1)

Y1 interface card used on IPX and IGX

BDA (Bframe Destination Address)

The address of the slot.port.channel for which the Bframe is destined. This address is part of the Bframe header and is only used across the switch fabric locally in the node.

Bframe

The BPX frame is the 64-byte format for messages used to encapsulate ATM cells which are sent across the switch fabric.

bipolar violations

Presence or absence of extra “1” bits on a T1 transmission facility caused by interference or a failing line repeater. These extra or missing bits interrupts one of the rules for bipolar pairs of a digital transmission line.

BISDN (broadband ISDN)

ITU-T communication standards designed to handle high-bandwidth applications. Compare with ISDN.

BNI (BPX Network Interface Card)

The front card used to network BPXs together and to connect to AXIS shelves, and IPX and IGX nodes configured as shelves. Supports T-3, E-3, and OC3 trunks carrying ATM cells.

BPX

A high-speed broadband, high-capacity ATM cell relay network switch from StrataCom for private and public networks.

BRI (Basic Rate Interface)

ISDN interface composed of two B channels and one D channel for circuit-switched communication of voice, video, and data. Compare with PRI.

bundled connections

Frame relay connections grouping a number of ports into one permanent virtual circuit.

BTM (Broadband Trunk Module)

The BTM provides an ATM trunk interface for the IGX. The BTM operates in conjunction with a backcard, AIT-T3 or AIT-E3.

BXM

A series of BPX cards, BXM-T3/E3, BXM-155, or BXM-622 which can be configured for either trunk or line (service access) modes. These cards support ATM Traffic Management 4.0, including VSVD congestion flow control.

C**CAS (Channel Associated Signalling)**

A signalling mode in E1 transmission where the signalling bits for all 30 E1 channels are carried in timeslot 16. Timeslots 1 to 15 and 17 to 31 carry encoded voice bits only.

CBR (Constant Bit Rate)

ATM Connection type for constant bit rate traffic such as voice or synchronized data requiring a low variation in delay. See also, VBR and ABR

CCDV (Compliant Cell Delay Variation)

A parameter utilized in defining ATM Constant Bit Rate service. The amount of delay that is acceptable between ATM cells for them to be accepted as compliant (usable).

CCITT (Consultive Committee for International Telephone and Telegraph)

An International telecommunications advisory committee established under the United Nations to recommend worldwide standards for data and voice communications.

CCS (Common Channel Signalling)

A carrier signalling mode in E1 transmission where signalling bits are not used. CCS typically separates user data from signalling information. A signalling channel is used to provide signalling for all other user data channels in the system.

CDP (Channelized Data PAD)

An IPX dual-purpose front card that can carry voice traffic, a combination of voice and data, or just data. The CVM card is used in conjunction with a BC-T1, BC-E1, or BC-J1 backcard.

CDVT (Cell Delay Variation Tolerance)

Controls time scale over which the PCR is policed.

Cell

A unit of data with a fixed number of bytes. For ATM the cell size is 53 bytes.

cell relay

A form of digital communications using fixed length cells consisting of data and a small header. IPX FastPacket was an early implementation of cell relay. The 53 byte ATM cell consists of data and a small header.

CEPT

CEPT is the European Conference of Posts and Telecommunications Administrations. This association is comprised of European Telecommunications service providers that participate in relevant areas of the work of CEN/CENELEC.

CGA (Carrier Group Alarm)

A major alarm condition for a T1 multiplexer or PABX that results in all channels being taken out of service.

channel

The logical end point for a connection.

circuit line

A T1 or E1 line that connects a user device, such as a PABX or channel bank to the IPX. Carries customer DS0 voice and data circuits. See also line.

clear channel capability

When all eight bits of a channel word in the T1 line signal are available for transmitting customer data with no restrictions on content. Also referred to as 64 Kbps clear channel.

Cmax

A frame relay connection parameter that specifies the number of packets allowed in the initial burst of data after which the data bandwidth is reduced to the connection's minimum specified bandwidth.

CLLM

Consolidated Link Layer Management. A protocol used to transmit ForeSight messages across the frame relay NNI port.

CLP (Cell loss priority)

Cell loss Priority. CLP Hi and CLP Lo thresholds are configurable.

Complex Gateway

Refers to interworking of a connection with respect to the IPX and IGX nodes. For example, in a Frame Relay to ATM interworking, the Frame Relay data is extracted from FastPackets and transformed to ATM cells with redundant overhead bits discarded.

composite data rate

The sum of the data rates for all circuits transmitting on the same synchronous or frame relay data card.

control port

An RS-232 port on the face plate of a back card for a controller card, (BCC, NPC, NPM) that may be used for connecting a control terminal. This port is bi-directional.

COS (Class of Service)

The priority assigned each user connection. Defines which circuits get rerouted first during a network failure.

courtesy downing

A software feature that is used to conserve network bandwidth by automatically “downing” a voice connection when the signalling status indicates an inactive (on-hook) circuit. The circuit is automatically “upped” when the circuit becomes active.

CRC (Cyclical Redundancy Check)

A method of error checking that detects errors in a block of data. Unlike parity checks, the CRC can detect multiple data errors within the block and thus equipment using a CRC error check can derive a error rate.

crosspoint switch

A two-dimensional data switch type that is arranged in a matrix of all input connections along one axis and all output connections along the other axis. Each input and output line has a switch point where the two axis intersect that can be enabled (switch closed) or disabled (switch open). The central matrix switch providing the switching matrix for traffic routing by the BPX node.

CSU (Channel Service Unit)

A network protection unit that terminates any T1 span line connected to the carrier's central office, providing receive direction regeneration and maintenance loopback for the 1.544 Mbps signal.

D**D4-format**

A digital signal format with 24 eight-bit channels plus one synchronizing bit per T1 line. Channels are assigned in a straight, numeric sequence.

DACS (Digital Access and Control System)

Equipment, usually found in the telephone company central office, that is used to groom and retime the 24 channels in a DS1 signal. Individual DS0 channels can be cross-connected from one DS1 source and inserted in another DS1 source either with the same or with a different channel number.

DAS Server Shelf

The adjunct processor used in INS Dial-Up Frame Relay applications to provide frame relay dial-up and dial-backup circuits. The DAS Server Shelf is co-located with and connected to an IPX or IGX.

DCE (Data Communications Equipment)

As defined by the RS-232 standard, any device that transmits or receives information. Usually used with data terminal equipment (DTE, like a computer or network node).

D channel

A message-oriented ISDN signalling channel, typically carried in DS24 of a PRI on T1 facilities or TS16 of a PRI on E1 facilities. Compare to B channel.

DDS (Digital Data Service).

An AT&T dial-up data service offering for 2.4 to 56 Kbps over subscriber loop cable. Requires a Data Service Unit, DSU, at customer premise for interface to the DDS trunk.

Device Code

The first 8 bits of a FastPacket Address.

DFM (Data Frame Multiplexing).

An optional feature that saves data channel bandwidth by analyzing data channel content and suppressing repetitive data patterns.

Dial Access Switching

Another name for the INS Dial-Up Frame Relay application.

Dial-Up Frame Relay

An INS application that uses a DAS Server Shelf and software to enhance StrataCom networks with frame relay soft permanent virtual circuits (SPVCs) for dial-up dial-backup connections.

DLCI (Data Link Connection Identifier)

A field in a frame relay data packet that identifies the destination for the data.

domain

A grouping of nodes sharing common interests or attributes.

domain name

A unique name consisting of the letter "D" immediately followed by a number (1–8) delineated by a "." (period) from the node name (1–8 characters maximum). Example: D1.alpha

domain number

A number from 1–8 assigned with the cnfdmn command. The number assigned is part of the domain name.

DPNSS

Digital Private Network Signalling System. A common-channel message-oriented signalling protocol commonly used by private branch exchanges (PBXes). The INS Voice Network Switching application supports DPNSS signalling.

DS0 (Digital Signal 0)

A 64 Kbps channel used to transmit encoded voice and/or data. There are 24 DS0 channels in a circuit T1 (DS1) line. DS0 data is transmitted using one or more DS0 circuits in a T1 or E1 circuit line.

DS0A

An extension of DS0 that defines the format for assembling various low-speed data circuits (1.2 to 19.6 Kbps) into a single 64 Kbps DS0 channel.

DS1 (Digital Signal 1)

A digital transmission standard that carries 24 individual channels in a bipolar, high-speed line signal at 1.544 Mbps. DS1 signal level is 3V.

DSI (Digital Speech Interpolation)

An algorithm that analyzes DS0 voice bits for non-speech codes. Suppresses these bits to conserve packet line bandwidth and inserts a code to indicate to the far end that these bits have been removed. Similar to DFM for data channels. Also, referred to as VAD (Voice Activity Detection).

DTE (Data Terminal Equipment)

As defined by the RS-232 standard, any device that generates or utilizes information. See also, DCE.

E

E1

European transmission service at the rate of 2.048 Mbps

E3

Transmission service at a rate of 34.368 Mbps

ECN (Explicit Congestion Notification)

A frame relay feature to signal the onset of network congestion to external devices. Sets FECN and BECN bits in frame relay header to indicate forward and backward congestion.

EFCI (Explicit Forward Congestion Indication)

ICR (Initial Cell Rate)

The rate at which a source should initially send after an idle period.

F

Fast EIA

Same as interleaved EIA. Seven data circuit control leads in each direction are transmitted in alternating bytes with data. For fast control lead response to data being turned on and off but with a sacrifice in packet line bandwidth.

FBTC (Frame Based Traffic Control)

An AAL5 frame based traffic control that provides the possibility of discarding the whole frame, not just one compliant cell. This avoids wasting bandwidth by continuing to send the cells in a frame once a cell has been found to be non-compliant.)

FGCRA (Frame Based Generic Cell Rate Algorithm)

An enhancement option to GCRA that allows an entire frame to be discarded if any of its cells are non-compliant, rather than transmitting a partial frame over the network.

flat network

A non-structured network, a network in which there are no junction nodes or domains.

foreign network

An adjacent network that is owned and managed by a different party than the one that owns the local network.

ForeSight

A proprietary optional feature that uses feedback techniques to dynamically allocate extra bandwidth to frame relay and ATM connections when the network bandwidth is available and not used by other connections. See also VSVD.

frame forwarding

A software feature allowing point-to-point frame relay type connection for various data applications that do not conform to the Frame Relay Interface Specification.

FPC (FastPAD Back Card)

The FPC is used with an FTC (IPX) or FTM (IGX) card. The FPC provides either a T1, E1, V.35, or X.21 interface.

frame relay connection class

A tag for a frame relay circuit which indicates the class of service to be provided for this connection. Parameters associated with a connection class include minimum information rate guaranteed, peak information rate expected, maximum network delay, etc.

FRI (Frame Relay Interface Card)

The backcard for an FRP (IPX) or FRM (IGX) card. The FRI provides V.35, X.21, T1, or E1 interfaces.

FRP (Frame Relay PAD)

An IPX frame relay front card that supports 1-4 data ports, and in single-port mode, operates up to 2.048 Mbps. The card is used in conjunction with FRI-V.35, X.21, T1, or E1 backcards.

FRM (Frame Relay Module)

An IGX frame relay front card that supports 1-4 data ports, and in single-port mode, operates up to 2.048 Mbps. The card is used in conjunction with FRI-V.35, X.21, T1, or E1 backcards.

FRM-2 (Frame Relay Module)

An IGX frame relay front card that provides an interface to the frame relay Port Concentrator Shelf (PCS). The card is used with the FRI-2-X.21 backcard which connects to the PCS.

FRP-2 (Frame Relay Module)

An IPX frame relay front card that provides an interface to the frame relay Port Concentrator Shelf (PCS). The card is used with the FRI-2-X.21 backcard which connects to the PCS.

FRP-2 (Frame Relay Module)

An IPX frame relay front card that provides an interface to the frame relay Port Concentrator Shelf (PCS). The card is used with the FRI-2-X.21 backcard which connects to the PCS.

Frame Relay Service

A packet interface data transmission protocol used for connecting widely-separated LANs. Characterized by long intervals of no data to be sent interspersed with bursts of large volumes of data; sometimes referred to as "bursty data".

frame slip

A T1 error condition caused by a timing problem between the network and the IPX. When this happens, the IPX inserts a blank DS1 frame or drops an idle DS1 frame so there is no loss of customer data.

FRTT (Fixed Round Trip Time)

The sum of the fixed and propagation delays from the source to a destination and back.

Full Status Report

A message sent across the NNI indicating the A-bit status of all connections routed across this NNI frame relay port.

FTC (FastPAD Trunk Card)

An IPX frame relay front card that provides an interface to a FastPAD. The FTC is used with an FPC backcard. that provides either a T1, E1, V.35, or X.21 interface.

FTM (FastPAD Trunk Module)

An IPX frame relay front card that provides an interface to a FastPAD.

G**gateway**

An IPX node that is configured to handle both T1 and E1 packet and circuit lines for direct interface international circuits. (See also Seamless International IPX Network.)

GCRA (Generic Cell Rate Algorithm)

GCRA is a “continuous leaky-bucket” process that monitors the cell depth in the input queue for each PVC to determine whether to admit a new cell to the network without setting the Cell Loss Priority bit.

global addressing

A frame relay addressing convention that uses the DLCI to identify a specific end device somewhere else in the frame relay network. In a global addressing scheme, the DLCI is a unique number for each port in the network.

grouped connections

Frame relay connections grouping a number of ports onto one permanent virtual circuit. Similar to bundled connections except the grouped connections do not have to be contiguous, nor do they all have to be added simultaneously.

H**HDB3 (High Density Bipolar Three)**

A new line interface for E1, similar to B8ZS for T1, which eliminates patterns with eight or more consecutive zeros. Allows for 64 Kbps clear channel operation and still assure the ones density required on the E1 line.

HDP (High Speed Data PAD)

An IGX front card that supports one to four medium speed, synchronous data channels.

I**IGX**

A multi-service, multi-band ATM cell relay network switch from StrataCom for private and public networks.

Intelligent Network Server (INS)

INS is the broad name for a range of products that enhance traditional StrataCom networks. These products include Dial-Up Frame Relay, Voice Network Switching, and ATM Switched Virtual Circuits.

intra-domain

Connections within a domain including but not going beyond the junction nodes.

inter-domain

Connections between domains through junction nodes.

interleaved EIA

Same as “Fast EIA”.

IPX

A narrowband cell relay network switch from StrataCom for private and public networks.

ISC (International Support Center)

The customer support group at StrataCom that provides assistance in solving network or equipment problems over the telephone.

ISDN (Integrated Services Digital Network)

A service provided by the telephone company or OCC that supports combined customer voice and data connections over the twisted pair subscriber loop. Requires special equipment at the customer premise and a connecting central office switch that is capable of providing ISDN.

J

J1

A. multiplexed 24-channel circuit line to a PBX conforming to the Japanese TTC-JJ-20 circuit standard. Similar to E1, it operates at 2.048 Mbps.

junction node

A node handling inter-networking of domains.

junction trunk

A packet line connecting junction nodes.

L

LCON

The logical connection used to represent an individual routing entity.

LDM (Low Speed Data Module)

An IGX data front card that supports up to 8 synchronous or asynchronous data ports. When used with an LDI4/DDS, an LDP can provide 56-Kbps Digital Data Service (DDS) interfaces to the IGX.

LDP (Low Speed Data PAD)

An IPX data front card that supports up to 8 synchronous or asynchronous data ports. When used with an LDI4/DDS, an LDP can provide 56-Kbps Digital Data Service (DDS) interfaces to the IPX.

LEC (Lower Expansion Card)

An expansion back card for the IPX32 that connects upper shelf bus to lower shelf bus and the active NPC to standby NPC.

line

Connects a user device to a service interface, for example, a router to an ASI or AUSM card, a data line to a data card, a frame relay line to an FRP or a port concentrator, or a T1 or E1 line to a CDP card.

link

The network connection between two nodes.

LMI (Local Management Interface)

The protocol and procedures for control of IPX frame relay connections. Used for configuration, flow control, and maintenance of these connections.

local addressing

A frame relay addressing convention that uses the DLCI to identify the IPX frame relay port at the interface between the user device and the frame relay network. In local addressing, a particular DLCI is used only at the local FR connection. The DLCI may be reused at any other IPX node in the network.

local alarm

An IPX alarm indicating that the associated T1 line is down due to a local failure of the its receive path.

local bus

An IPX utility bus (LB/0 or LB/1), located on the midplane, which provides the electrical connections between various front and back cards. For example, the front and back cards of the Low Speed Data PAD group (LDP and LDI) plug into this utility bus.

logical port

A frame relay circuit consisting of either 1, 6, 24 (T1), or 31 (E1) contiguous DSO's on a T1 or E1 physical port.

M

major alarm

A local or remote failure that is affecting operation of the network.

MBS (Maximum Burst Size)

Maximum number of cells which may burst at the PCR but still be compliant.

MCR (Minimum Cell Rate)

The minimum cell rate that is supported by an ATM connection for an ABR connection.

MIR (Minimum Information Rate)

The minimum information rate that is supported by a frame relay connection.

minor alarm

A local or remote failure that is not affecting operation of the network, but nonetheless should be investigated.

MUXBUS

A high-speed IPX backplane bus that carries data and timing between card slots for both circuit line and packet line data. Consists of the TDM bus carrying the data and the system clock bus that is used to synchronize all data flowing on and off the TDM bus.

N

n+1 redundancy

A redundancy method in which a group of cards share the same standby redundant card.

Network-to-Network Interface (NNI)

The protocol at a frame relay port that serves as a bidirectional interface between a local StrataCom network and a separate and independent “other” network.

node

An IPX/IGX/BPX serving as a connection point to the network. At a node, connections from service lines are routed to trunks for transmission to other nodes in the network.

NPC (Network Processor Card)

Micro-processor based system controller front card that contains the software used to operate the IPX.

NPM (Network Processor Module)

Micro-processor based system controller front card that contains the software used to operate the IGX.

Nrm

Maximum number of cells a source may send for each forward RM cell, i.e., an RM cell must be sent for every Nrm-1 data cells.

NTC (Network Trunk Card)

IPX front card that coordinates fastpacket trunk traffic to another node via a number of backcards: T1, E1, Y1, and subrate (RS449, X.21, and V.35)

NTM (Network Trunk Module)

IGX front card that coordinates fastpacket trunk traffic to another node via a number of backcards: T1, E1, Y1, and subrate (RS449, X.21, and V.35)

O

OC-3

Standard optical transmission facility rate of 155.20 Mbps.

OCC (Other Common Carrier).

In the United States, reference to all the other telecommunications companies providing various transmission services other than AT&T.

P

packet line

Packet line referred to a line used to carry FastPackets between IPX nodes in a network. The term in these documents is replaced by the more general “trunk” which is defined as a physical link from node to node, node to shelf, or node to network. The trunk may be one that supports 24-byte FastPackets (packet trunk), or one that supports 53 byte ATM cells (cell trunk).

packet switching

A system that breaks data strings into small units (packets), then individually addresses and routes them through the network.

PAD (Packet Assembler/Disassembler)

A device that converts a serial data stream into discrete packets in the transmit direction and converts the received packets back into a serial data stream. Adds header information in the transmit packet to allow it to be routed to the proper destination.

partially-interleaved EIA

One control lead in each direction, generally RTS-CTS, is transmitted in same byte as seven data bits. For fast control lead response to data being turned on and off.

PBX (private branch exchange)

Digital or analog telephone switchboard, classified as customer premise equipment (CPE), used to connect private and public telephone networks

PCM (Pulse Code Modulation)

The system for transmitting telephone signals digitally. Voice is sampled 8000 times per second and converted to an 8-bit digital word.

PCR (Peak Cell Rate)

The maximum rate for an ATM connection at which cells are allowed into the network.

PCS (Port Concentrator Shelf)

The PCS is an external shelf that expands the capacity of the FRP card. The PCS is sued with the FRP-2 (IPX) or FRM-2 (IGX) card to 44 frame relay connections. The PCS connects to the FRI-2.X.21 backcard.

PIR (Peak Information Rate)

The peak level in bits per second allowed for a frame relay connection.

PLCP (Physical Layer Convergence Protocol)

A protocol defined for use with Switched Megabit Data Service. Used on DS3 ATM trunks in the BPX.

PLPP (Physical Layer Protocol Processor)

A custom VLSI processor used in the T3 ATM port interface of the BPX BNI card to handle the coding and decoding of the PLCP bit structure. Functions handled by the PLPP include header check sequence generation and checking, DS3 framing, and optional payload scrambling/descrambling.

plesiochronous network

A network where there is more than one source of network timing. The multiples sources must be operating at the same frequency but are not phase locked (synchronous) with each other.

port

Refers to a signal connection on a data back card that interfaces to a customer circuit or data device. The number of ports on a card ranges from 1 to 8 depending on the particular card type.

PRI (Primary Rate Interface)

An ISDN interface to primary rate access. Primary rate access consists of a single D channel for signalling and 23 (T1) or 30 (E1) B (bearer) channels for user data. A PRI is typically carried on T1 or E1 facilities.

privilege level

A level between 1 and 6 that is assigned to each IPX command. Each operator is assigned a privilege level by the system administrator. The operator may only access and execute commands equal to or lower than his or her own privilege level. Level 1 is the highest and level 6 is the lowest.

PVCs

Permanent Virtual Connections (circuits). Connections that are assigned but not connected until data is sent, thereby not using bandwidth when idle.

Q**Q.921/Q.931**

ITU-T specifications for the ISDN user network interface (UNI) data link layer.

QSIG

A common-channel message-oriented signalling protocol, defined by the European Telecommunications Standard Institute (ETSI), commonly used by private branch exchanges (PBXes). The INS Dynamic Network Switching application supports QSIG signalling to the StrataCom network.

queue

A buffer that is used to temporarily hold data while it waits to be transmitted to the network or to the user.

R**RIF (Rate increase factor)**

Controls the amount by which the cell transmission rate may increase upon receipt of an RM cell.

RDF (Rate decrease factor)

Controls the amount by which the cell transmission rate may decrease upon receipt of an RM cell.

red alarm

Another name for local alarm as the local alarm lamp on most digital transmission equipment is red in color.

remote alarm

An IPX alarm indicating that the associated T1 line is down due to a receive line failure on another node. See also yellow alarm.

RPS (repetitive pattern suppression)

Also called data frame multiplexing (DFM). An option for data circuits where repeating strings of data are replaced on the packet line by a single occurrence of the data string and a code that indicates to the far end how many repetitions of the string was being transmitted. Used to conserve network bandwidth.

robbed bit signaling

A type of signaling used on T1 lines where the signaling bits for each channel are substituted for the least significant voice bit in each channel word during frames 6 and 12.

RS-232

A physical and electrical interface standard for a low-speed, unbalanced, serial, data interface adopted by the EIA committee on data communications. Generally used for data circuits operating at data rates below 56 Kbps.

RS-422/423

Another EIA standard electrical interface for serial data circuits operating at higher data rates than RS232. RS422 is a balanced interface; RS423 is unbalanced. Uses RS-449 for the physical interface (connector).

RS-449

The physical interface for the RS422 and R423 electrical interfaces. Contains the Processor Controller Card and the PCC utility bus, and provides system timing and control via the system bus.

S

SAR (Segmentation and Reassembly)

The process of breaking a dataframe containing data from a number of virtual paths or circuits apart so that the individual paths/circuits can be switched by reassembling the data into a new frame with a different sequence.

SCC (System Clock Card)

An IPX backcard that works in conjunction with the NPC. The SCC provides a centralized clock generation function and provides serial and LAN port interfaces.

SCM (System Clock Module)

An IGX backcard that works in conjunction with the NPM. The SCM provides a centralized clock generation function and provides serial and LAN port interfaces.

SCR (Sustainable Cell Rate)

Rate above which incoming cells are either tagged or discarded.

SDP (Synchronous Data PAD)

An IPX front card that supports one to four medium speed, synchronous data channels.

SDI (Synchronous Data Interface)

The back card for the SDP (IPX) or HDM (IGX) cards. The SDI is available with V.24, X.21, and V.35 interfaces.

seamless international network

An IPX network that is configured to carry traffic over international borders (E1-T1 or T1-E1)—see also gateway.

Simple Gateway

Refers to FastPacket to ATM interworking with respect to the IPX and IGX nodes. In the simple gateway mode, FastPackets are encapsulated in their entirety into cells. See also, complex gateway.

SIU (Serial Interface Unit)

A set of circuits common to all BPX cards used for transmitting and receiving via the crosspoint switch.

Soft PVC

A PVC in the INS Dial-Up Frame Relay application that is dormant in the networks database until it is activated by a call into the network by a user.

spanning tree

An IPX network topology in which there is only one path available between any two sources in a frame relay multicast group. Spanning trees are required to prevent frames broadcast from a single source to multiple receptors from circulating endlessly around the network a result of frame relay circuits not having properly closed loops.

speech detection

Determining the presence or absence of speech for Digital Speech Interpolation. Performed in either the CDP card or VDP card in an IPX node.

split clock

A data clocking configuration where the timing for the transmit data is obtained from one source (e.g. user device) and the timing for the receive data is obtained from another source (e.g. IPX).

Status Enquiry

A message transmitted by a FR NNI port requesting an updated status from the attached foreign network. This message is used as a heartbeat to detect when a port has failed.

StrataBus

On the BPX, contains crosspoint wiring used to carry ATM trunk data between both the network interface and service interface modules and the crosspoint switch as well as providing control, clock, and communications.

StrataView Plus

A Unix-based workstation and software used as a network management system (NMS) for StrataCom networks. It is part of the StrataSphere group. Provides a graphical user interface for configuration, maintenance, administration of the network. Collects and displays network statistics.

StrataSphere

A standards based multi-protocol management architecture that includes StrataView Plus, StrataSphere Connection Manager, StrataSphere BILLder, StrataSphere Modeler, and StrataSphere Optimizer.

subrate data

Multiple low-speed data circuits carried in a single DS0 timeslot.

superrate data

Single high-speed data circuit carried in multiple DS0 timeslots.

SCR (Sustained Cell Rate)

Long term limit on the rate a connection can sustain.

SVC (switched virtual circuit)

A virtual circuit that is dynamically established on demand and torn down when transmission is complete. SVCs do not need to reserve any network resources when they are not in use. Called a switched virtual connection in ATM terminology. Compare with PVC.

system bus

A two-part IPX data bus. One part carries system commands between the PCC all other IPX cards; the other carries time division multiplexed data.

T

T1

The standard US. multiplexed 24-channel voice/data digital span line. Operates at a data rate of 1.544 Mbps.

T3

Transmission service at DS3 rate of 44.736 Mbps

TBE (Transient Buffer Exposure)

The negotiated number of cells that the network would prefer to limit the source to send during the start-up period.

TDM (time division multiplexing)

The process of combining several communication channels by dividing a channel into time increments and assigning each channel to a timeslot.

timestamp

A field in certain FastPacket formats that indicates the amount of time the packet has spent waiting in queues during the transmission between its source and destination nodes. Used to control the delay experienced by the packet.

Trm

An upper bound on the time between RM cells for an active source, i.e., RM cell must be sent at least once every Trm msec.

trunk

A physical link between two nodes. The trunk may be one that supports 24-byte FastPackets (packet trunk), or one that supports 53 byte ATM cells (cell trunk)

trunk conditioning

A set of signalling and information bits that indicate a DS1 line failure.

trunk queues

The buffers in packet line cards (NTC, TXR) where the various FastPackets are queued up for transmission over the packet line(s). The buffers attempt to prioritize each packet so it experiences minimum delay.

U

-law

An analog to digital encoding scheme used to convert voice samples to an 8-bit data word used in D3/D4 T1 multiplex equipment.

UBR

Unspecified Bit Rate

UNI (User to Network Interface)

The user to network interface, as for ATM connection to CPE. See also NNI.

UPC (Usage Parameter Control)

A general procedure for controlling the rate of user data applied to an ATM network. There are a number of different algorithms for performing UPC. See also GRCA.

USART (Universal Synchronous/Asynchronous Receiver Transmitter)

A single-chip device used in certain applications that allows microprocessors to communicate with input/output (I/O) devices.

User to Network Interface (UNI)

The protocol at a frame relay port that passes information between the network and the user device attached to the port.

V**V.21**

A CCITT interface standard often used for data transmission over modems.

V.35

A data communications interface standard adopted by the CCITT. Often used for data circuits operating at 56 Kbps and above.

VAD (Voice Activity Detection).

Used to statistically compress voice by not sending packets in the absence of speech.

VBR (Variable Bit Rate)

Connection type for variable bit rate traffic such as bursty data. See also, CBR and ABR.

VC QDepth**VC_Q**

Frame relay buffer allocation parameter that specifies the maximum queue size reserved in the FRP card for the FR connection.

virtual circuit

A circuit that acts like it is an individual transmission path but is actually shared with other circuits over a single transmission path. See also PVCs.

VNS

The adjunct processor used in the INS Voice Network Switching application. The VNS is co-located with and connected to an IGX or IPX.

Voice Network Switching

An INS application used to provide voice or data switched virtual circuits over a StrataCom network for PBXes using either QSIG or DPNSS signalling.

VS/VD (Virtual Source/Virtual Destination)

ATM Forum Traffic Management 4.0 method of providing congestion flow control for ABR connection types. Resource Management (RM) cells are used to convey management information between sources and destinations.

vt (virtual terminal)

An IPX control terminal that is the active control terminal at one node but is physically attached to another node.

W

WAN (Wide Area Network)

A network of transmission circuits generally spanning a large region or territory for transmission of voice and data between widespread end users. An IPX network is an example of a WAN.

X

X.21

A CCITT standard for data interfaces transmitting at rates up to approximately 2 Mbps.

X.25

A commonly-used standard that defines the protocol for low-speed data packet networks

XON/XOFF

A simple communications protocol for controlling the flow of data from one device to another. An XON sent from a receiving device indicates it is ready to accept data and the transmitting device may begin to output data. An XOFF from the receiving device indicates that it can no longer store any more data and the transmitting device should temporarily cease transmitting.

Y

Y-cable(s)

A short adapter cable forming an electrical branch (thus the term Y) for connecting a single customer data or trunk connection to two identical back cards to provide hardware redundancy on the IPX.

Y-cable redundancy

A redundancy type used in the IPX when a 1:1 card redundancy is implemented using a split or Y-cable for the data connection between the user device and the primary and standby IPX interface card.

Y1

A digital trunk conforming to the Japanese “Y” circuit standard, for use as a packet line. Similar to T1, it operates at 1.544 Mbps.

yellow alarm

Another name for remote alarm as the remote alarm lamp on digital transmission equipment is always yellow in color.

Symbols

%Util 4-10
 (Flow Control External Segment 4-10)

A

AAL5 Frame Base Traffic Control 4-10
 ABR (Available Bit Rate) 4-3
 ABR and ATFST Connections 4-18
 ABR STD 4-11
 ADTF 4-11
 AT3-6M Interface Adapter xix, D-1
 ATM connections
 definition 4-1
 ATM Forum Traffic Management 4.0 4-3
 auto-dial modem C-7
 AutoRoute 36
 AXIS Reference Manual xx
 See Related documentation

B

BPX
 Cabling Summary B-1
 Features 27
 peripherals specifications xix, C-1
 BPX Reference Manual xx
 See Related documentation
 BXM 3-1
 BXM, ATM Connections 4-8
 BXM-15 4-1
 BXM-155 3-1
 BXM-622 3-1, 4-1
 BXM-T3/E3 3-1, 4-1

C

card
 status 6-4
 caution
 symbol, defined xxi
 CBR (Constant Bit Rate) 4-3
 CBR Connections 4-14
 CDVT(0+1) 4-10
 CI 4-4
 Circuit Emulation Service 4-14
 class of service 35
 closed-loop 37, 4-5
 CLP 4-10

CLP Hi 4-11
 CLP Lo 4-11
 Command Reference Manual xx
 See Related documentation
 Configuration 5-1
 congestion management 37, 4-5
 Connection Parameters 4-10
 conventions, documentation xx

D

DC Power
 Power Entry Module 6-9
 diagnostics 28, 29, 40
 display card status 6-4
 DNS Installation and Operation manual
 overview xviii
 documentation
 conventions xx

E

EFCI 4-11
 ER 4-4
 explicit rate 4-4

F

FAIL lights 6-2
 FBTC 4-10
 FCES 4-10
 features 27
 ForeSight 37, 4-5
 FRTT 4-11

I

IBS 4-11
 ICR 4-11
 IGX Reference Manual xx
 See Related documentation
 Installation
 ac power supply, redundant 6-12
 International Support Center 38
 Introduction 9-1
 IPX Reference Manual xx
 See Related documentation

M

MBS 4-10
MCR 4-10
MIB II Support 9-5
Modems
 Auto-Answer at ISC C-5
 Auto-Dial to ISC C-7
 Codex 3220 C-5
modems
 cable C-7

N

Network Interface 37
Network Management 37
Network Statistics 38
network synchronization 39
NI 4-4
Node
 alarms 40
 availability factor 40
 redundancy options 40
 Synchronization 39
Nrm 4-11
nrt-VBR (Non-Real Time Variable Bit Rate) 4-3

O

OptiClass 35

P

PCR 4-10
PEM (DC Power Entry Module) 6-9
Policing 4-10
preventive maintenance 6-1

R

RDF 4-11
Related documentation xx
 IGX Installation Manual xx
 IPX Installation Manual xx
replacement
 AC Power Supply 6-11
 AC power supply 6-11
 card slot fuse 6-15
 DC Power Entry Module 6-9

fan assembly 6-14
front cards 6-5
line module 6-7
parts 6-5
temperature sensing unit 6-15
Resource Management 4-4
RIF 4-11
RM 4-4
RM cells 4-4
rt-VBR (Real-Time Variable Bit Rate) 4-3

S

SCR 4-10
self tests 3- 6-1
Service Interfaces 38
SNMP Functions 9-3
SNMP Overview 9-1
specifications
 ATM E3 trunk interface A-7, A-8
 ATM Service Interface, T3/E3 A-10, A-11
 ATM T3 trunk interface A-6
 BPX peripherals xix, C-1
 system xix, A-1
SrataCom Proprietary MIB Structure 9-6
Standard ABR 4-4
StrataView Plus NMS workstation 37
StrataView Plus Operations Guide xx
symbols, defined xxi
system specifications A-1

T

TBE 4-11
temperature 40
timesaver symbol, defined xxi
Traffic Policing Definitions 4-9
Trm 4-11
troubleshooting the BPX 6-1

U

UBR (Unspecified Bit Rate) 4-3
UBR Connections 4-23
User Service Interfaces 38

V

VBR and ATFR Connections 4-15

VC Qdepth 4-11
Virtual circuit connections (VCCs) 37
virtual trunk 33
Virtual Trunking 33
VSVD 4-10

