



Cisco Unified CallManager Release 5.0-PBX Interoperability: Avaya Definity G3 MV1.3 to a Cisco Catalyst 6000 using CMM-T1 QSIG with MGCP

Initial version, August 14, 2006

Table of Contents

Introduction	1
Network Topology.....	2
Limitations.....	3
Call Forward by Join External.....	3
System Components	3
Hardware Requirements	3
Software Requirements	3
Features	3
Features Supported.....	3
Configuration.....	4
Configuration Sequence and Tasks	4
Configuration Menus and Commands	5
Cisco Unified CallManager Configuration.....	17
Cisco CMM-T1 Gateway Configuration	101
PSTN Gateway (Cisco 3745) Configuration	106
Acronyms	109

Introduction

This is an application note for connectivity of Avaya Definity G3 MV1.3 PBX with Cisco Unified CallManager Release 5.0 using Cisco Communication Media Module (CMM)-T1 QSIG as MGCP gateway.

The network topology diagram (Figure 1) shows the test setup for end-to-end interoperability with the Cisco Unified CallManager connected to the PBX via Cisco Communication Media Module CMM-T1 QSIG link as MGCP gateway.

Connectivity is achieved by using the PRI QSIG T1 protocol type on the MGCP gateway and ISO QSIG switch type on the of Avaya Definity G3 MV1.3 PBX.

This Application Note uses the Cisco CMM-T1 voice gateway; however, other Cisco voice gateways are also an option to use since Cisco Unified CallManager QSIG implementation does not depend on the physical interface.



Network Topology

Figure 1. Network Topology or Test Setup

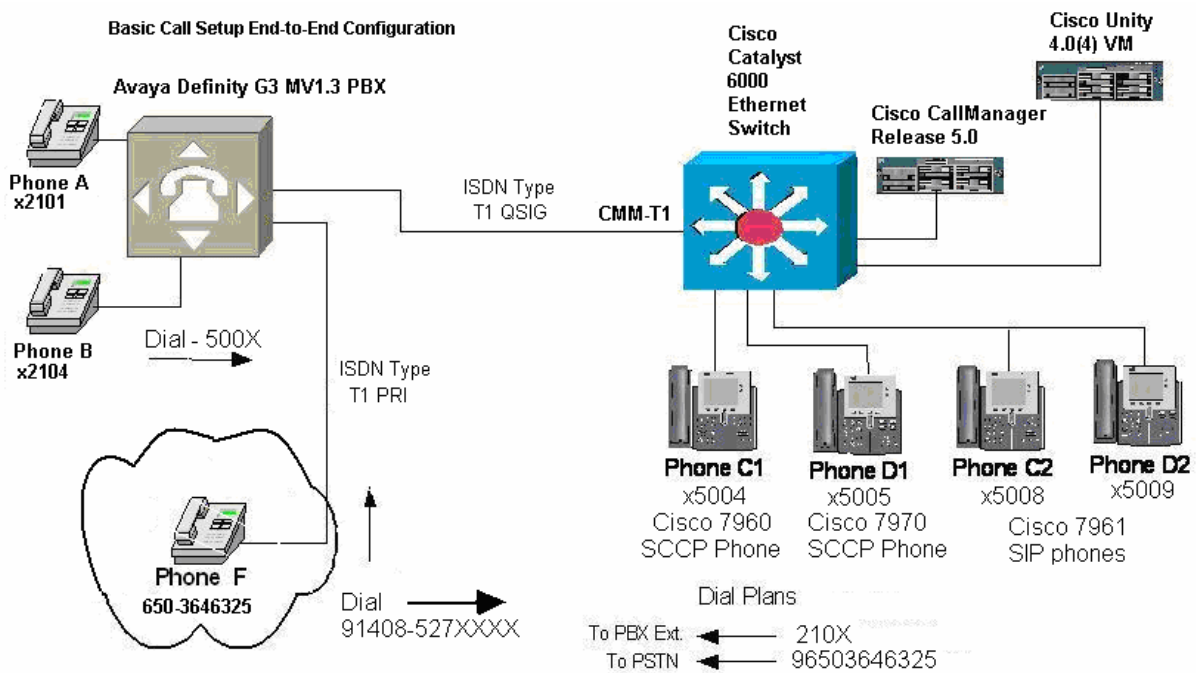



Limitations

Call Forward by Join External

As of this round of testing, Avaya Definity G3 MV1.3 PBX does not do External Call Forward By Join (Unconditional, Busy or No Reply) since it automatically performs Call Diversion by Reroute to complete the call. Thus, Call diversion by Reroute happens instead of External Call Forward By Join when a phone on the Avaya Definity G3 MV1.3 PBX is the forwarding station and Cisco Unified CallManager phones are the originating and final destination phones respectively

As of publication of this Application Note, Rerouting cannot be turned off on the Avaya Definity G3 MV1.3 PBX

System Components

Hardware Requirements

Cisco Catalyst 6000 switch with CMM-T1 Gateway

Cisco Unified CallManager Server

Avaya Definity G3 MV1.3 PBX

Software Requirements

Avaya MV1.3

Cisco Unified CallManager 5.0

Features

Features Supported

CLIP-Calling Line (Number) Identification Presentation

CLIR-Calling Line (Number) Identification Restriction

CNIP-Calling Name Identification Presentation

CNIR-Calling Name Identification Restriction

COLP-Connected Line (Number) Identification Presentation

COLR- Connected Line (Number) Identification Restriction

CONP-Connected Name Identification Presentation

CONR- Connected Name Identification Restriction

Sending Alerting Name

CT-Call Transfer

CFU-Call Forwarding Unconditional (by join) – see Limitations Section

CFB-Call Forwarding Busy (by join) – see Limitations Section

CFNR-Call Forwarding No Reply (by join) – see Limitations Section

CFU-Call Forwarding Unconditional (by Reroute)

CFB-Call Forwarding Busy (by Reroute)

CFNR-Call Forwarding No Reply (by Reroute)

CCBS-Call Completion to Busy Subscriber

CCNR-Call Completion No Reply



ANF-PR-Additional Network Feature Path Replacement (for Call Transfer by join)

ANF-PR-Additional Network Feature Path Replacement (for Call Diversion by forward switching)

ANF-PR-Additional Network Feature Path Replacement (for Trombone connection)

MWI- Message Waiting Indication (lamp ON, lamp OFF)

Configuration

Configuration Sequence and Tasks

Configuring the Avaya Definity G3 MV1.3 PBX

Configure in the following sequence:

1. Add the new circuit pack.
2. Add the new signaling group.
3. Add the new trunk group.
4. Add Uniform Dialing Plan.



Configuration Menus and Commands

Avaya Configuration

DS1 Circuit Pack

```
Avaya Site Administration - [multivantage Emulation: 513]
File Edit View System Action Tools Window Help
cancel refresh enter clear help go to page next page prev page
display ds1 1a12 Page 1 of 2
DS1 CIRCUIT PACK
Location: 01A12 Name: T1 QSIG to CCM
Bit Rate: 1.544 Line Coding: b8zs
Line Compensation: 1 Framing Mode: esf
Signaling Mode: isdn-pri
Connect: pbx Interface: peer-master
TN-C7 Long Timers? n Peer Protocol: Q-SIG
Interworking Message: PROGRESS Side: a
Interface Companding: mulaw CRC? n
Idle Code: 11111111
DCP/Analog Bearer Capability: 3.1kHz
Slip Detection? n Near-end CSU Type: other
```

Signaling Group

```
Avaya Site Administration - [multivantage Emulation: 513]
File Edit View System Action Tools Window Help
cancel refresh enter clear help go to page next page prev page
display signaling-group 12
SIGNALING GROUP
Group Number: 12 Group Type: isdn-pri
Associated Signaling? y Max number of NCA TSC: 10
Primary D-Channel: 01A1224 Max number of CA TSC: 10
Trunk Group for Channel Selection: 12 Trunk Group for NCA TSC: 12
Supplementary Service Protocol: b X-Mobility/Wireless Type: NONE
```



Trunk Group (1 of 3)

```
Avaya Site Administration - [multivantage Emulation: 513]
File Edit View System Action Tools Window Help
cancel refresh enter clear help go to page next page prev page
display trunk-group 12 Page 1 of 10
TRUNK GROUP
Group Number: 12          Group Type: isdn          CDR Reports: y
Group Name: QSIG to CM-POLARIS  COR: 1          TN: 1          TAC: 612
Direction: two-way      Outgoing Display? n      Carrier Medium: PRI/BRI
Dial Access? y          Busy Threshold: 99       Night Service:
Queue Length: 0
Service Type: tie          Auth Code? n          TestCall ITC: rest
                          Far End Test Line No:
TestCall BCC: 4
TRUNK PARAMETERS
Codeset to Send Display: 0      Codeset to Send National IEs: 6
Max Message Size to Send: 260  Charge Advice: none
Supplementary Service Protocol: b  Digit Handling (in/out): enbloc/enbloc
Trunk Hunt: ascend            QSIG Value-Added? y
                          Digital Loss Group: 13
Calling Number - Delete:      Insert:          Numbering Format: unk-unk
                          Bit Rate: 1200      Synchronization: async Duplex: full
Disconnect Supervision - In? y Out? y
```

Trunk Group (2 of 3)

```
Avaya Site Administration - [multivantage Emulation: 513]
File Edit View System Action Tools Window Help
cancel refresh enter clear help go to page next page prev page
display trunk-group 12 Page 2 of 10
TRUNK FEATURES
ACA Assignment? n          Measured: none          Wideband Support? n
                          Internal Alert? n        Maintenance Tests? y
Data Restriction? n        NCA-TSC Trunk Member: 1
                          Send Name: y            Send Calling Number: y
Used for DCS? n            Hop Dgt? y
Suppress # Outpulsing? n    Numbering Format: unknown
Outgoing Channel ID Encoding: preferred  UUI IE Treatment: service-provider
                          Replace Restricted Numbers? y
                          Replace Unavailable Numbers? y
                          Send Called/Busy/Connected Number: y
Send UUI IE? y
Send UCID? y
Send Codeset 6/7 LAI IE? y          Ds1 Echo Cancellation? n
Path Replacement with Retention? y
SBS? n Network (Japan) Needs Connect Before Disconnect? n
```



Trunk Group (3 of 3)

Avaya Site Administration - [multivantage Emulation: 513]

File Edit View System Action Tools Window Help

cancel refresh enter clear help go to page next page prev page

display trunk-group 12 Page 4 of 10

TRUNK GROUP

Administered Members (min/max): 1/8
Total Administered Members: 8

GROUP MEMBER ASSIGNMENTS	Port	Code	Sfx	Name	Night	Sig	Grp
1:	01A1201	TN464	F			12	
2:	01A1202	TN464	F			12	
3:	01A1203	TN464	F			12	
4:	01A1204	TN464	F			12	
5:	01A1220	TN464	F			12	
6:	01A1221	TN464	F			12	
7:	01A1222	TN464	F			12	
8:	01A1223	TN464	F			12	
9:							
10:							
11:							
12:							
13:							
14:							
15:							

Uniform Dialing Plan

display uniform-dialplan 5 Page 1 of 2

UNIFORM DIAL PLAN TABLE

Percent Full: 0

Matching Pattern	Len	Del	Insert Digits	Net	Conv	Node Num	Matching Pattern	Len	Del	Insert Digits	Net	Conv	Node Num
5003	4	0	512	aar	n		5110	4	0	530	aar	n	
5004	4	0	512	aar	n		53	4	0	530	aar	n	
5005	4	0	512	aar	n		54	4	0	999	aar	n	
5006	4	0	512	aar	n		5555	4	0	512	aar	n	
5007	4	0	512	aar	n		7	4	0	777	aar	n	
5008	4	0	512	aar	n							n	
5009	4	0	512	aar	n							n	
5017	4	0	530	aar	n							n	
5020	4	0	530	aar	n							n	
5050	4	0	512	aar	n							n	
509	4	0	512	aar	n							n	
5100	4	0	512	aar	n							n	
5102	4	0	510	aar	n							n	
5103	4	0	510	aar	n							n	
5105	4	0	512	aar	n							n	
5109	4	0	530	aar	n							n	



AAR Digit Analysis

display aar analysis 512

AAR DIGIT ANALYSIS TABLE							Percent Full:	3
Dialed String	Total Min	Total Max	Route Pattern	Call Type	Node Num	ANI Reqd		
512	7	7	12	aar	3	n		
515	7	7	15	aar		n		
530	7	7	13	aar	4	n		
531	7	7	13	aar	6	n		
555	7	7	105	aar		n		
611	7	7	13	aar		n		
613	7	7	13	aar		n		
614	7	7	14	aar	2	n		
777	7	7	13	aar		n		
888	7	7	15	aar		n		
998	7	7	11	aar		n		
999	7	7	98	aar		n		
						n		
						n		
						n		

Route Patterns

display route-pattern 12

Pattern Number: 12 Pattern Name:												
Grp No	FRL	NPA	Pfx Mrk	Hop Lmt	Toll List	No. Del	Inserted Dgts		DCS/ QSIG Intw	IXC		
1:	12	0					3		n	user		
2:									n	user		
3:									n	user		
4:									n	user		
5:									n	user		
6:									n	user		

Grp No	BCC	VALUE	TSC	CA-TSC Request	ITC	BCIE	Service/Feature	BAND	No. Dgts	Numbering Format	LAR
1:	y	y	y	y	y	n	y	as-needed	rest	unk-unk	none
2:	y	y	y	y	y	n	n		rest		none
3:	y	y	y	y	y	n	n		rest		none
4:	y	y	y	y	y	n	n		rest		none
5:	y	y	y	y	y	n	n		rest		none
6:	y	y	y	y	y	n	n		rest		none



Station Configuration (1 of 2)

```
display station 2101                                     Page 1 of 4
STATION
Extension: 2101                                         Lock Messages? n      BCC: 0
Type: 6408D+                                           Security Code:        TN: 1
Port: 01A0407                                          Coverage Path 1:     COR: 1
Name: John Adams                                       Coverage Path 2:     COS: 1
                                                         Hunt-to Station:

STATION OPTIONS
    Loss Group: 2                                       Personalized Ringing Pattern: 1
    Data Module? n                                     Message Lamp Ext: 2101
    Speakerphone: 2-way                               Mute Button Enabled? y
    Display Language: english

                                                         Media Complex Ext:
                                                         IP SoftPhone? n
                                                         Remote Office Phone? n
```

Station Configuration (2 of 2)

```
display station 2101                                     Page 2 of 4
STATION
FEATURE OPTIONS
    LWC Reception: spe                                  Auto Select Any Idle Appearance? n
    LWC Activation? y                                  Coverage Msg Retrieval? y
    LWC Log External Calls? n                          Auto Answer: none
    CDR Privacy? n                                     Data Restriction? n
    Redirect Notification? y                           Idle Appearance Preference? n
    Per Button Ring Control? n                          Restrict Last Appearance? y
    Bridged Call Alerting? n
    Active Station Ringing: single

    H.320 Conversion? n                               Per Station CPN - Send Calling Number?
    Service Link Mode: as-needed
    Multimedia Mode: basic
    MWI Served User Type:

    Audible Message Waiting? n
    Display Client Redirection? n
    Select Last Used Appearance? n
    Coverage After Forwarding? s
    Multimedia Early Answer? n
    Direct IP-IP Audio Connections? y
    IP Audio Hairpinning? y

Emergency Location Ext: 2101
```



System Parameters and Customer Options

display system-parameters customer-options

Page 7 of 9

QSIG OPTIONAL FEATURES

```
Basic Call Setup? y
Basic Supplementary Services? y
Centralized Attendant? y
Interworking with DCS? y
Supplementary Services with Rerouting? y
Transfer into QSIG Voice Mail? y
Value-Added (VALU)? y
```

(NOTE: You must logoff & login to effect the permission changes.)

System Parameters Features

display system-parameters features

Page 7 of 12

FEATURE-RELATED SYSTEM PARAMETERS

ISDN PARAMETERS

```
Send Non-ISDN Trunk Group Name as Connected Name? n
Display Connected Name/Number for ISDN DCS Calls? n
Send ISDN Trunk Group Name on Tandem Calls? n
```

```
QSIG TSC Extension: 2099
MWI - Number of Digits Per Voice Mail Subscriber: 4
Feature Plus Ext: 2098
National CPN Prefix:
International CPN Prefix:
Pass Prefixed CPN to ASAI? n
Unknown Numbers Considered Internal for AUDIX? y Maximum Length: 4
USNI Calling Name for Outgoing Calls? y
Path Replacement with Measurements? y
QSIG Path Replacement Extension: 2097
Path Replace While in Queue/Vectoring? y
```



Dial Plan Parameters

```
Avaya Site Administration - [multivantage Emulation: 513]
File Edit View System Action Tools Window Help
cancel refresh enter clear help go to page next page prev page
display dialplan parameters
DIAL PLAN PARAMETERS
Local Node Number: 1
ETA Node Number:
ETA Routing Pattern:
UDP Extension Search Order: local-extensions-first
6-Digit Extension Display Format: xx.xx.xx
7-Digit Extension Display Format: xxx-xxxx
```

ISDN Private Numbering

```
Avaya Site Administration - [multivantage Emulation: 513]
File Edit View System Action Tools Window Help
cancel refresh enter clear help go to page next page prev page
display isdn private-numbering
ISDN NUMBERING - PRIVATE FORMAT
Network Level: 0 PBX Identifier: 408
Level 2 Code: Deleted Digits: 0
Level 1 Code:
```



Feature Access Code (1 of 3)

```
Avaya Site Administration - [multivantage Emulation: 513]
File Edit View System Action Tools Window Help
cancel refresh enter clear help go to page next page prev page
display feature-access-codes Page 1 of 7
FEATURE ACCESS CODE (FAC)
Abbreviated Dialing List1 Access Code:
Abbreviated Dialing List2 Access Code:
Abbreviated Dialing List3 Access Code:
Abbreviated Dial - Prgm Group List Access Code:
Announcement Access Code:
Answer Back Access Code:
Auto Alternate Routing (AAR) Access Code: 8
Auto Route Selection (ARS) - Access Code 1: 9 Access Code 2:
Automatic Callback Activation: Deactivation:
Call Forwarding Activation Busy/DA: *66 All: *67 Deactivation: *69
Call Park Access Code:
Call Pickup Access Code:
CAS Remote Hold/Answer Hold-Unhold Access Code:
CDR Account Code Access Code:
Change COR Access Code:
Change Coverage Access Code:
Data Origination Access Code:
Data Privacy Access Code:
```

Feature Access Code (2 of 3)

```
Avaya Site Administration - [multivantage Emulation: 513]
File Edit View System Action Tools Window Help
cancel refresh enter clear help go to page next page prev page
display feature-access-codes Page 2 of 7
FEATURE ACCESS CODE (FAC)
Emergency Access to Attendant Access Code:
Enhanced EC500 Activation: Deactivation:
Extended Call Fwd Activate Busy D/A All: Deactivation:
Extended Group Call Pickup Access Code:
Facility Test Calls Access Code:
Flash Access Code:
Group Control Restrict Activation: Deactivation:
Hunt Group Busy Activation: Deactivation:
ISDN Access Code:
Last Number Dialed Access Code:
Leave Word Calling Message Retrieval Lock:
Leave Word Calling Message Retrieval Unlock:
Leave Word Calling Send A Message: *77
Leave Word Calling Cancel A Message: *78
Malicious Call Trace Activation: Deactivation:
Meet-me Conference Access Code Change:
PASTE (Display PBX data on Phone) Access Code:
Personal Station Access (PSA) Associate Code: Dissociate Code:
```



Feature Access Code (3 of 3)

```
Avaya Site Administration - [multivantage Emulation: 513]
File Edit View System Action Tools Window Help
cancel refresh enter clear help go to page next page prev page
display feature-access-codes Page 4 of 7
FEATURE ACCESS CODE (FAC)
Whisper Page Activation Access Code: *65
```

PSTN DS1 Circuit Pack

```
Avaya Site Administration - [multivantage Emulation: 513]
File Edit View System Action Tools Window Help
cancel refresh enter clear help go to page next page prev page
display ds1 1a15 Page 1 of 2
DS1 CIRCUIT PACK
Location: 01A15 Name:
Bit Rate: 1.544 Line Coding: b8zs
Line Compensation: 1 Framing Mode: esf
Signaling Mode: isdn-pri
Connect: pbx Interface: network
TN-C7 Long Timers? n Country Protocol: 1
Interworking Message: PROGRESS Protocol Version: a
Interface Companding: mulaw CRC? n
Idle Code: 11111111
DCP/Analog Bearer Capability: 3.1kHz
Slip Detection? n Near-end CSU Type: other
```



PSTN Signaling Group

```
Avaya Site Administration - [multivantage Emulation: 513]
File Edit View System Action Tools Window Help
cancel refresh enter clear help go to page next page prev page
display signaling-group 15 Page 1 of 5
SIGNALING GROUP
Group Number: 15          Group Type: isdn-pri
Associated Signaling? y   Max number of NCA TSC: 10
Primary D-Channel: 01A1524 Max number of CA TSC: 10
Trunk Group for Channel Selection: 15 Trunk Group for NCA TSC: 15
Supplementary Service Protocol: a      X-Mobility/Wireless Type: NONE
```

PSTN Trunk Group (1 of 3)

```
Avaya Site Administration - [multivantage Emulation: 513]
File Edit View System Action Tools Window Help
cancel refresh enter clear help go to page next page prev page
display trunk-group 15 Page 1 of 10
TRUNK GROUP
Group Number: 15          Group Type: isdn          CDR Reports: y
Group Name: Deepa test QSIG trunk COR: 1      TN: 1      TAC: 615
Direction: two-way       Outgoing Display? y      Carrier Medium: PRI/BRI
Dial Access? y           Busy Threshold: 99       Night Service:
Queue Length: 0
Service Type: tie        Auth Code? n             TestCall ITC: rest
Far End Test Line No:
TestCall BCC: 4
TRUNK PARAMETERS
Codeset to Send Display: 0 Codeset to Send National IEs: 6
Max Message Size to Send: 260 Charge Advice: none
Supplementary Service Protocol: a Digit Handling (in/out): enbloc/enbloc
Trunk Hunt: ascend       QSIG Value-Added? n
Digital Loss Group: 13
Calling Number - Delete: Insert:             Numbering Format:
Bit Rate: 1200           Synchronization: async Duplex: full
Disconnect Supervision - In? y Out? y
```



PSTN Trunk Group (2 of 3)

```

Avaya Site Administration - [multivantage Emulation: 513]
File Edit View System Action Tools Window Help
cancel refresh enter clear help go to page next page prev page
display trunk-group 15 Page 2 of 10
TRUNK FEATURES
  ACA Assignment? n           Measured: none           Wideband Support? n
                               Internal Alert? n         Maintenance Tests? y
                               Data Restriction? n      NCA-TSC Trunk Member:
                               Send Name: n             Send Calling Number: y
  Used for DCS? n
  Suppress # Outpulsing? n    Numbering Format: public
  Outgoing Channel ID Encoding: preferred  UUI IE Treatment: service-provider
                               Replace Restricted Numbers? n
                               Replace Unavailable Numbers? n
                               Send Connected Number: y
  Send UUI IE? y
  Send UCID? n
  Send Codeset 6/7 LAI IE? y           Ds1 Echo Cancellation? n
                               US NI Delayed Calling Name Update? n
  SBS? n  Network (Japan) Needs Connect Before Disconnect? n

```

PSTN Trunk Group (3 of 3)

```

Avaya Site Administration - [multivantage Emulation: 513]
File Edit View System Action Tools Window Help
cancel refresh enter clear help go to page next page prev page
display trunk-group 15 Page 4 of 10
TRUNK GROUP
  Administered Members (min/max): 1/8
  Total Administered Members: 8
GROUP MEMBER ASSIGNMENTS
  Port   Code Sfx Name      Night      Sig Grp
  1: 01A1501 TN464 F              15
  2: 01A1502 TN464 F              15
  3: 01A1503 TN464 F              15
  4: 01A1504 TN464 F              15
  5: 01A1520 TN464 F              15
  6: 01A1521 TN464 F              15
  7: 01A1522 TN464 F              15
  8: 01A1523 TN464 F              15
  9:
  10:
  11:
  12:
  13:
  14:
  15:

```



PSTN ARS Digit Analysis Table

Avaya Site Administration - [multivantage Emulation: 513]

File Edit View System Action Tools Window Help

cancel refresh enter clear help go to page next page prev page

display ars analysis 650 Page 1 of 2

ARS DIGIT ANALYSIS TABLE
Location: all Percent Full: 3

Dial String	Total		Route Pattern	Call Type	Node Num	ANI Reqd
	Min	Max				
650	10	10	15	natl		n
9	28	28	11	natl		n
						n
						n
						n
						n
						n
						n
						n
						n
						n
						n
						n
						n
						n
						n
						n
						n

PSTN Route Pattern

Avaya Site Administration - [multivantage Emulation: 513]

File Edit View System Action Tools Window Help

cancel refresh enter clear help go to page next page prev page

display route-pattern 15 Pattern Number: 15 Pattern Name:

Grp No	FRL	NPA	Pfx Mrk	Hop Lmt	Toll List	No. Del	Inserted Digits	DCS/ QSIG Intw	IXC
1:	15	0				0		n user	
2:								n user	
3:								n user	
4:								n user	
5:								n user	
6:								n user	

Grp No	BCC	VALUE	TSC	CA-TSC Request	ITC	BCIE	Service/Feature	BAND	No. Dgts	Numbering Format	LAR
1:	y	y	y	y	y	n	y	none	rest		none
2:	y	y	y	y	y	n	n		rest		none
3:	y	y	y	y	y	n	n		rest		none
4:	y	y	y	y	y	n	n		rest		none
5:	y	y	y	y	y	n	n		rest		none



Cisco Unified CallManager Configuration

Gateway Configuration - 1

The screenshot shows the Cisco Unified CallManager Administration web interface. The browser window is titled "Find and List Gateway - Microsoft Internet Explorer". The address bar shows the URL: `https://172.20.236.50/ccmadmin/gatewayFindList.do?lookup=false&multiple=true&recCnt=11&colCnt=17`. The page header includes "Cisco Unified CallManager Administration" and "Logged in as: CCMAdministrator". The navigation menu includes "System", "Call Routing", "Media Resources", "Voice Mail", "Device", "Application", "User Management", "Bulk Administration", and "Help". The main content area is titled "Find and List Gateway" and shows a search result for "CMM-POLARIS".

Status
1 records found

Search Options
Find Gateways where Name begins with CMM Hide endpoints Find Search Within Results
(device.name begins with CMM) Select item or enter search text

Search Results

	Device Name	Description	Device Pool	Calling Search Space	Ext. Partition	Route Group	Priority	Port	Device Type	Status	IP Address
<input type="checkbox"/>	CMM-POLARIS	CMM in cat 6500 slot 4 - bench 8							Communication Media Module	See Endpoints	

Buttons: Add New, Select All, Clear All, Delete Selected, Reset Selected. Rows per Page: 50



Gateway Configuration - 2

Gateway Configuration - Microsoft Internet Explorer

File Edit View Favorites Tools Help

Navigation Cisco Unified CallManager Administration Go

Cisco Unified CallManager Administration For Cisco IP Telecommunication Solutions Logged in as: CCMAdministrator

System Call Routing Media Resources Voice Mail Device Application User Management Bulk Administration Help Log Off

Gateway Configuration Related Links: Back To Find/List Go

Status
Status: Ready

Gateway Details

Product	Communication Media Module
Gateway	CMM-POLARIS
Protocol	MGCP
Domain Name *	CMM-POLARIS
Description	CMM in cat 6500 slot 4 - bench 8
Cisco Unified CallManager Group *	Default

Configured Slots, VICs and Endpoints

Module in Slot 1 WS-X6600
Subunit 0 WS-X6600-6T1 1/0 T1P1 1/1 1/2 T1P1 1/3 1/4 T1P1 1/5

Module in Slot 2 < None >

Module in Slot 3 < None >

Module in Slot 4 < None >

Product Specific Configuration

Global ISDN Switch Type	4ESS
Switchback Timing *	Graceful
Switchback uptime-delay (min)	10
Switchback schedule (hh:mm)	12:00
Fax mode *	Fax Relay

Save Delete Reset Add New

*- indicates required item.

Done

Start Tera Term - COM1... Tera Term - COM2... 172.20.33.51 - Te... ORIGIN~1 - Word... Cannot find serve... Gateway Config... Document - Word... Local intranet 10:02 AM



Gateway Configuration - 3

Gateway Configuration - Microsoft Internet Explorer

File Edit View Favorites Tools Help

Navigation Cisco Unified CallManager Administration Go

Cisco Unified CallManager Administration For Cisco IP Telecommunication Solutions Logged in as: CCMAdministrator

System Call Routing Media Resources Voice Mail Device Application User Management Bulk Administration Help Log Off

Gateway Configuration Related Links: Back to MGCP Configuration Go

Status
Status: Ready

Device Information

Product	Cisco MGCP T1 Port
Gateway	CMM-POLARIS
Device Protocol	Digital Access PRI
Registration	Registered with Cisco Unified CallManager 172.20.236.50
IP Address	172.20.236.170
End-Point Name *	S1/DS1-0@CMM-POLARIS
Description	Avaya MV1.1 - Trunk Group 12
Device Pool*	Default
Call Classification*	OnNet
NetworkLocale	United States
Media Resource Group List	MRGL_Polaris
Location*	Hub_None
AAR Group	< None >
Load Information	

Transmit UTF-8 for Calling Party Name

Multilevel Precedence and Preemption (MLPP) Information

MLPP Domain	< None >
MLPP Indication*	Off
MLPP Preemption*	Disabled

Interface Information

PRI Protocol Type*	PRI ISO QSIG T1
Protocol Side*	User
Channel Selection Order*	Top Down
Channel IE Type*	Use Number when 1B

Done

Start Tera Term - COM1... Tera Term - COM2... 172.20.33.51 - Te... ORIGIN~1 - Word... Cannot find serve... Gateway Config... Document - Word... Local intranet 10:03 AM



Gateway Configuration - 4

Gateway Configuration - Microsoft Internet Explorer

File Edit View Favorites Tools Help Links

Interface Information

PRI Protocol Type* PRI ISO QSIG T1
Protocol Side* User
Channel Selection Order* Top Down
Channel IE Type* Use Number when 1B
PCM Type* μ -law
Delay for first restart (1/8 sec ticks)* 32
Delay between restarts (1/8 sec ticks)* 4

Inhibit restarts at PRI initialization
 Enable status poll
 Unattended Port

Call Routing Information - Inbound Calls

Significant Digits* All
Calling Search Space tp_phones_rp
AAR Calling Search Space tp_phones_rp
Prefix DN

Call Routing Information - Outbound Calls

Calling Party Presentation* Default
Calling Party Selection* Originator
Called party IE number type unknown* Cisco CallManager
Calling party IE number type unknown* Cisco CallManager
Called Numbering Plan* Cisco CallManager
Calling Numbering Plan* Cisco CallManager
Number of digits to strip* 0
Caller ID DN
SMDI Base Port* 0

PRI Protocol Type Specific Information

Display IE Delivery
 Redirecting Number IE Delivery - Outbound
 Redirecting Number IE Delivery - Inbound
 Send Extra Leading Character in Display IE****
 Setup non-ISDN Progress Indicator IE Enable****

Done Local intranet

Start Tera Term - COM1... Tera Term - COM2... 172.20.33.51 - Te... ORIGIN~1 - Word... Cannot find serve... Gateway Config... Document - Word... 10:03 AM



Gateway Configuration - 5

Gateway Configuration - Microsoft Internet Explorer

File Edit View Favorites Tools Help Links

PRI Protocol Type Specific Information

Display IE Delivery

Redirecting Number IE Delivery - Outbound

Redirecting Number IE Delivery - Inbound

Send Extra Leading Character in Display IE***

Setup non-ISDN Progress Indicator IE Enable****

MCDN Channel Number Extension Bit Set to Zero**

Send Calling Name In Facility IE

Interface Identifier Present**

Interface Identifier Value**

Connected Line ID Presentation (QSIG Inbound Call)*

UUIE Configuration

Passing Precedence Level Through UUIE

Security Access Level*

Product Specific Configuration ?

Line Coding *

Framing *

Clock *

Input Gain (-6..14 db) *

Output Attenuation (-6..14 db) *

Echo Cancellation Enable *

Echo Cancel Coverage (ms) *

Save Delete Reset

i *- indicates required item.

i ** - applies to DMS-100 protocol only.

i *** - applies to DMS-100 protocol and DMS-250 protocol only.

i **** - may be required to force ringback from some PBXs.

i ***** - Device reset is not required for changes to Packet Capture Mode and Packet Capture Duration.

Done Local intranet

Start Tera Term - COM1... Tera Term - COM2... 172.20.33.51 - Te... ORIGIN~1 - Word... Cannot find serve... Gateway Config... Document - Word... 10:03 AM



Gateway Configuration - 6

Gateway Configuration - Microsoft Internet Explorer

File Edit View Favorites Tools Help

Navigation Cisco Unified CallManager Administration Go

Cisco Unified CallManager Administration For Cisco IP Telecommunication Solutions Logged in as: CCMAdministrator

System Call Routing Media Resources Voice Mail Device Application User Management Bulk Administration Help Log Off

Gateway Configuration Related Links: Back to MGCP Configuration Go

Status
Status: Ready

Device Information

Product	Cisco MGCP T1 Port
Gateway	CMM-POLARIS
Device Protocol	Digital Access PRI
Registration	Registered with Cisco Unified CallManager 172.20.236.50
IP Address	172.20.236.170
End-Point Name *	S1/DS1-4@CMM-POLARIS
Description	Avaya V7 - Trunk Group 11
Device Pool*	Default
Call Classification*	OnNet
NetworkLocale	United States
Media Resource Group List	MRGL_Polaris
Location*	Hub_None
AAR Group	< None >
Load Information	

Transmit UTF-8 for Calling Party Name

Multilevel Precedence and Preemption (MLPP) Information

MLPP Domain	< None >
MLPP Indication*	Off
MLPP Preemption*	Disabled

Interface Information

PRI Protocol Type*	PRI ISO QSIG T1
Protocol Side*	User
Channel Selection Order*	Top Down
Channel IE Type*	Use Number when 1B

Done

Start Tera Term - COM1... Tera Term - COM2... 172.20.33.51 - Te... ORIGIN~1 - Word... Cannot find serve... Gateway Config... Document - Word... Local intranet 10:07 AM



Gateway Configuration - 7

Gateway Configuration - Microsoft Internet Explorer

File Edit View Favorites Tools Help Links

PRI Protocol Type Specific Information

Display IE Delivery

Redirecting Number IE Delivery - Outbound

Redirecting Number IE Delivery - Inbound

Send Extra Leading Character in Display IE

Setup non-ISDN Progress Indicator IE Enable

MCDN Channel Number Extension Bit Set to Zero

Send Calling Name In Facility IE

Interface Identifier Present

Interface Identifier Value

Connected Line ID Presentation (QSIG Inbound Call)

UUIE Configuration

Passing Precedence Level Through UUIE

Security Access Level*

Product Specific Configuration

Line Coding *

Framing *

Clock *

Input Gain (-6..14 db) *

Output Attenuation (-6..14 db) *

Echo Cancellation Enable *

Echo Cancel Coverage (ms) *

Save Delete Reset

i *- indicates required item.
i ** - applies to DMS-100 protocol only.
i *** - applies to DMS-100 protocol and DMS-250 protocol only.
i **** - may be required to force ringback from some PBXs.
i ***** - Device reset is not required for changes to Packet Capture Mode and Packet Capture Duration.

Done Local intranet

Start Tera Term - COM1... Tera Term - COM2... 172.20.33.51 - Te... ORIGIN~1 - Word... Cannot find serve... Gateway Config... Document - Word... 10:07 AM



Phone Configuration - 1

Phone Configuration - Microsoft Internet Explorer

File Edit View Favorites Tools Help

Phone Configuration Related Links: Back To Find/List Go

Status: Ready

Association Information

Modify Button Items

- Line [1] - 5004 in phones
- Line [2] - Add a new DN
- Add a new SD
- Add a new SD
- Add a new SD
- Add a new SD
- Unassigned Associated Items -----
- Add a new SD
- Add a new SURL
- Add a new BLF SD
- Privacy
- None

Phone Type
Product Type: Cisco 7960
Device Protocol: SCCP

Device Information

Registration	Registered with Cisco Unified CallManager 172.20.236.50
IP Address	172.20.236.8
MAC Address*	000BBEAD4C1C
Description	Lab test phone (5004)
Device Pool*	Default
Phone Button Template*	Standard 7960 SCCP
Softkey Template	Qsig Custom
Common Phone Profile*	Standard Common Phone Profile
Calling Search Space	rp_phones
AAR Calling Search Space	rp_phones
Media Resource Group List	MRGL_Polaris
User Hold Audio Source	1-SampleAudioSource
Network Hold Audio Source	1-SampleAudioSource
Location*	Hub_None
User Locale	English United States
Network Locale	United States
Built In Bridge*	Default
Privacy*	Default
Owner User ID	< None >
Phone Load Name	

Retry Video Call as Audio
 Ignore Presentation Indicators (internal calls only)
 Allow Control of Device from CTI

Protocol Specific Information

Done

Start Tera Term - COM1 VT Tera Term - COM2 VT CCM_5.02 Testing Phone Configuration - ... Local intranet 11:26 AM



Phone Configuration - 2

Phone Configuration - Microsoft Internet Explorer

File Edit View Favorites Tools Help Links

Retry Video Call as Audio
 Ignore Presentation Indicators (internal calls only)
 Allow Control of Device from CTI

Protocol Specific Information

Packet Capture Mode*
Packet Capture Duration
Presence Group*
SCCP Phone Security Profile*
SUBSCRIBE Calling Search Space
 Unattended Port
 Require DTMF Reception
 RFC2833 Disabled

Expansion Module Information

Module 1
Module 1 Load Name
Module 2
Module 2 Load Name

External Data Locations Information (Leave blank to use default)

Information
Directory
Messages
Services
Authentication Server
Proxy Server
Idle
Idle Timer (seconds)

Extension Information

Enable Extension Mobility
Log Out Profile
Login in User ID
Log in Time

Local intranet

Start | Tera Term - COM1 VT | Tera Term - COM2 VT | CCM_5.02 Testing | Phone Configuration - ... | CCM5.02_Polaris_PhoneC... | 11:26 AM



Phone Configuration - 3

Phone Configuration - Microsoft Internet Explorer

File Edit View Favorites Tools Help Links

Extension Information

Enable Extension Mobility

Log Out Profile: -- Not Selected --

Log in User ID: < None >

Log in Time: < None >

Log out Time: < None >

Certification Authority Proxy Function (CAPF) Information

Certificate Operation*: No Pending Operation

Authentication String:

Operation Completes By: 2006 : 8 : 5 : 12 (YYYY:MM:DD:HH)

Certificate Operation Status: None

MLPP Information

MLPP Domain: < None >

MLPP Indication*: Default

MLPP Preemption*: Default

Secure Shell Information

Secure Shell User:

Secure Shell Password:

Product Specific Configuration Layout ?

Disable Speakerphone

Disable Speakerphone and Headset

PC Port *: Enabled

Settings Access*: Enabled

Gratuitous ARP*: Enabled

PC Voice VLAN Access*: Enabled

Video Capabilities*: Disabled

Auto Line Select*: Disabled

Web Access*: Enabled

Save Delete Copy Reset Add New

Local intranet

Start Tera Term - COM1 VT Tera Term - COM2 VT CCM_5.02 Testing Phone Configuration - ... CCM5.02_Polaris_PhoneC... 11:27 AM



Phone Configuration - 4

Phone Configuration - Microsoft Internet Explorer

Navigation Cisco Unified CallManager Administration Go

Cisco Unified CallManager Administration For Cisco IP Telecommunication Solutions Logged in as: CCMAdministrator

System Call Routing Media Resources Voice Mail Device Application User Management Bulk Administration Help Log Off

Phone Configuration Related Links: Back To Find/List Go

Status
Status: Ready

Association Information
Modify Button Items

- Line [1] - 5008 in phones
- Line [2] - Add a new DN
- Add a new SD
- Add a new SD
- Add a new SD
- Add a new SD
- Unassigned Associated Items -----
Add a new SD
- Add a new SURF
- Add a new BLF SD
- Privacy
- None

Phone Type
Product Type: Cisco 7961
Device Protocol: SIP

Device Information

Registration	Registered with Cisco Unified CallManager 172.20.236.50
IP Address	172.20.236.28
MAC Address*	00170EEE32C6
Description	SIP test phone - 5008
Device Pool*	Default
Phone Button Template*	Standard 7961 SIP
Softkey Template	Qsig Custom
Common Phone Profile*	Standard Common Phone Profile
Calling Search Space	tp_phones_rp
AAR Calling Search Space	tp_phones_rp
Media Resource Group List	MRGL_Polaris
User Hold Audio Source	1-SampleAudioSource
Network Hold Audio Source	1-SampleAudioSource
Location*	Hub_None
User Locale	English United States
Network Locale	United States
Built In Bridge*	Default
Privacy*	Default
Owner User ID	< None >
Phone Load Name	

Ignore Presentation Indicators (internal calls only)

Start | Tera Term - [disco... | Tera Term: Log | Tera Term - COM1 VT | CCM_Polaris5.02_A... | CCM_5.02 Testing | Phone Configura... | CCM_5.02_Avaya... | 9:44 AM



Phone Configuration - 5

Phone Configuration - Microsoft Internet Explorer

File Edit View Favorites Tools Help Links

Privacy*

Owner User ID

Phone Load Name

Ignore Presentation Indicators (internal calls only)

Allow Control of Device from CTI

Protocol Specific Information

Packet Capture Mode*

Packet Capture Duration

Presence Group*

SIP Dial Rules

MTP Preferred Originating Codec*

SIP Phone Security Profile*

Rerouting Calling Search Space

SUBSCRIBE Calling Search Space

SIP Profile*

Digest User

Media Termination Point Required

Unattended Port

Require DTMF Reception

External Data Locations Information (Leave blank to use default)

Information

Directory

Messages

Services

Authentication Server

Proxy Server

Idle

Idle Timer (seconds)

Extension Information

Enable Extension Mobility

Log Out Profile

Start | Tera Term - [disco... | Tera Term: Log | Tera Term - COM1 VT | CCM_Polaris5.02_A... | CCM_5.02 Testing | Phone Configura... | CCM_Polaris5.02_E... | 9:46 AM



Phone Configuration - 6

Phone Configuration - Microsoft Internet Explorer

File Edit View Favorites Tools Help

Time timer (Seconds)

Extension Information

Enable Extension Mobility

Log Out Profile: -- Not Selected --

Login in User ID: < None >

Log in Time: < None >

Log out Time: < None >

Certification Authority Proxy Function (CAPF) Information

Certificate Operation*: No Pending Operation

Authentication String:

Operation Completes By: 2006 : 8 : 12 : 12 (YYYY:MM:DD:HH)

Certificate Operation Status: None

MLPP Information

MLPP Domain: < None >

Secure Shell Information

Secure Shell User:

Secure Shell Password:

Product Specific Configuration Layout

Disable Speakerphone

Disable Speakerphone and Headset

PC Port *: Enabled

Settings Access*: Enabled

Gratuitous ARP*: Enabled

PC Voice VLAN Access*: Enabled

Video Capabilities*: Disabled

Auto Line Select*: Disabled

Web Access*: Enabled

Span to PC Port*: Disabled

Logging Display*: PC Controlled

Load Server:

Start | Tera Term - [disco... | Tera Term: Log | Tera Term - COM1 VT | CCM_Polaris5.02_A... | CCM_5.02 Testing | Phone Configura... | CCM_Polaris5.02_E... | 9:46 AM



Phone Configuration - 7

Phone Configuration - Microsoft Internet Explorer

File Edit View Favorites Tools Help Links

Log out Time < None >

Certification Authority Proxy Function (CAPF) Information

Certificate Operation*

Authentication String

Operation Completes By : : : (YYYY:MM:DD:HH)

Certificate Operation Status: None

MLPP Information

MLPP Domain

Secure Shell Information

Secure Shell User

Secure Shell Password

Product Specific Configuration Layout ?

Disable Speakerphone

Disable Speakerphone and Headset

PC Port *

Settings Access*

Gratuitous ARP*

PC Voice VLAN Access*

Video Capabilities*

Auto Line Select*

Web Access*

Span to PC Port*

Logging Display*

Load Server

*- indicates required item.

**- Device reset is not required for changes to Packet Capture Mode and Packet Capture Duration.

Start | Tera Term - [disco... | Tera Term: Log | Tera Term - COM1 VT | CCM_Polaris5.02_A... | CCM_5.02 Testing | Phone Configura... | CCM_Polaris5.02_Extras - WordPad | 9:46 AM



Phone Configuration - 8

Phone Configuration - Microsoft Internet Explorer

Navigation Cisco Unified CallManager Administration Go

Cisco Unified CallManager Administration For Cisco IP Telecommunication Solutions Logged in as: CCMAdministrator

System Call Routing Media Resources Voice Mail Device Application User Management Bulk Administration Help Log Off

Phone Configuration Related Links: Back To Find/List Go

Status
Status: Ready

Association Information
Modify Button Items

- Line [1] - 5005 in phones
- Line [2] - Add a new DN
- Add a new SD
- Add a new SD
- Add a new SD
- Add a new SD
- Add a new SD
- Add a new SD
- Unassigned Associated Items -----
- Add a new SD
- Add a new SURL
- Add a new BLF SD
- Privacy
- None

Phone Type
Product Type: Cisco 7970
Device Protocol: SCCP

Device Information

Registration	Registered with Cisco Unified CallManager 172.20.236.50
IP Address	172.20.236.35
MAC Address*	000E839C1543
Description	7970 Set - Bench 8 (5005)
Device Pool*	Default
Phone Button Template*	Standard 7970 SCCP
Softkey Template	Qsig Custom
Common Phone Profile*	Standard Common Phone Profile
Calling Search Space	tp_phones_rp
AAR Calling Search Space	tp_phones_rp
Media Resource Group List	MRGL_Polaris
User Hold Audio Source	1-SampleAudioSource
Network Hold Audio Source	1-SampleAudioSource
Location*	Hub_None
User Locale	< None >
Network Locale	< None >
Built In Bridge*	Default
Privacy*	Default
Owner User ID	< None >
Phone Load Name	

Retry Video Call as Audio

Start | Tera Term - [disco... | Tera Term: Log | Tera Term - COM1 VT | CCM_Polaris5.02_A... | CCM_5.02 Testing | Phone Configura... | CCM_Polaris5.02_E... | 9:51 AM



Phone Configuration - 9

Phone Configuration - Microsoft Internet Explorer

File Edit View Favorites Tools Help Links

Privacy*

Owner User ID

Phone Load Name

Retry Video Call as Audio

Ignore Presentation Indicators (internal calls only)

Allow Control of Device from CTI

Protocol Specific Information

Packet Capture Mode*

Packet Capture Duration

Presence Group*

SCCP Phone Security Profile*

SUBSCRIBE Calling Search Space

Unattended Port

Require DTMF Reception

RFC2833 Disabled

Expansion Module Information

Module 1

Module 1 Load Name

Module 2

Module 2 Load Name

External Data Locations Information (Leave blank to use default)

Information

Directory

Messages

Services

Authentication Server

Proxy Server

Idle

Idle Timer (seconds)

Extension Information

Enable Extension Mobility

Start | Tera Term - [disco... | Tera Term: Log | Tera Term - COM1 VT | CCM_Polaris5.02_A... | CCM_5.02 Testing | Phone Configura... | CCM_Polaris5.02_E... | 9:51 AM



Phone Configuration - 10

Phone Configuration - Microsoft Internet Explorer

File Edit View Favorites Tools Help Links

Idle
Idle Timer (seconds)

Extension Information

Enable Extension Mobility

Log Out Profile

Login in User ID
Log in Time
Log out Time

Certification Authority Proxy Function (CAPF) Information

Certificate Operation*

Authentication String

Operation Completes By : : : (YYYY:MM:DD:HH)

Certificate Operation Status: None

MLPP Information

MLPP Domain

MLPP Indication*

MLPP Preemption*

Secure Shell Information

Secure Shell User

Secure Shell Password

Product Specific Configuration Layout ?

Disable Speakerphone
 Disable Speakerphone and Headset

PC Port *

Settings Access*

Gratuitous ARP*

PC Voice VLAN Access*

Video Capabilities*

Auto Line Select*

Web Access*

Phone Configuration - 9:51 AM



Phone Configuration - 11

Phone Configuration - Microsoft Internet Explorer

File Edit View Favorites Tools Help Links

MLPP Information

MLPP Domain < None >
MLPP Indication* Default
MLPP Preemption* Default

Secure Shell Information

Secure Shell User
Secure Shell Password

Product Specific Configuration Layout ?

Disable Speakerphone
 Disable Speakerphone and Headset

PC Port * Enabled
Settings Access* Enabled
Gratuitous ARP* Enabled
PC Voice VLAN Access* Enabled
Video Capabilities* Disabled
Auto Line Select* Disabled
Web Access* Enabled
Days Display Not Active Sunday
Monday
Tuesday
Display On Time 07:30
Display On Duration 10:30
Display Idle Timeout 01:00
Span to PC Port* Disabled
Logging Display* PC Controlled
Load Server

Save Delete Copy Reset Add New

*- indicates required item.
 **- Device reset is not required for changes to Packet Capture Mode and Packet Capture Duration.

Start | Tera Term - [disco... | Tera Term: Log | Tera Term - COM1 VT | CCM-Polaris5.02_A... | CCM_5.02 Testing | Phone Configura... | CCM-Polaris5.02_E... | 9:51 AM



Directory Number Configuration - 1

Directory Number Configuration - Microsoft Internet Explorer

Navigation Cisco Unified CallManager Administration Go

Cisco Unified CallManager Administration For Cisco IP Telecommunication Solutions Logged in as: CCAdministrator

System Call Routing Media Resources Voice Mail Device Application User Management Bulk Administration Help Log Off

Directory Number Configuration Related Links: Back To Find/List Go

Status
Status: Ready

Note: Changes to Line or Directory Number settings require restart.

Directory Number Information

Directory Number* 5004

Route Partition phones

Description

Alerting Name 5004-Alt-Pol

ASCII Alerting Name 5004-Alt-Pol

Allow Control of Device from CTI

Associated Devices

SEP000BBEAD4C1C	Edit Device
SEP112233445566	Edit Line Appearance

Dissociate Devices

Directory Number Settings

Voice Mail Profile Unity1 (Choose <None> to use system default)

Calling Search Space rp_phones

Presence Group* Standard Presence group

AAR Group pbxlab_AAR_group_1

User Hold Audio Source < None >

Network Hold Audio Source < None >

Done

Start Tera Term - C... Tera Term - C... 172.20.33.51 -... ORIGIN-v1 - W... Microsoft Outlo... Directory Nu... Untitled - Mes... Local intranet 10:20 AM



Directory Number Configuration - 2

Directory Number Configuration - Microsoft Internet Explorer

File Edit View Favorites Tools Help Links

Presence Group* Standard Presence group

AAR Group pbxlab_AAR_group_1

User Hold Audio Source < None >

Network Hold Audio Source < None >

Auto Answer* Auto Answer Off

Call Forward and Call Pickup Settings

Forward All or Voice Mail Destination tp_phones_rp Calling Search Space tp_phones_rp

Secondary Calling Search Space for Forward All < None > Find

Forward Busy Internal or tp_phones_rp

Forward Busy External or tp_phones_rp

Forward No Answer Internal or tp_phones_rp

Forward No Answer External or tp_phones_rp

Forward No Coverage Internal or tp_phones_rp

Forward No Coverage External or tp_phones_rp

Forward on CTI Failure or < None >

No Answer Ring Duration (seconds)

Call Pickup Group < None >

MLPP Alternate Party Settings

Target (Destination)

MLPP Calling Search Space < None >

MLPP No Answer Ring Duration (seconds)

Line 1 on Device SEP000BEAD4C1C

	Value	Update Shared Device Settings
Display (Internal Caller ID)	5004-Polaris Display text for a line appearance is intended for displaying text such as a name instead of a directory number for internal calls. If you specify a number, the person receiving a call may not see the proper identity of the caller.	<input type="checkbox"/>
ASCII Display (Internal Caller ID)	5004-Polaris	<input type="checkbox"/>
Line Text Label	5004-Polaris	<input type="checkbox"/>
ASCII Line Text Label	5004-Polaris	<input type="checkbox"/>

Done Local intranet

Start Tera Term - C... Tera Term - C... 172.20.33.51 -... ORIGIN-v1 - W... Microsoft Outlo... Directory Nu... Untitled -- Mes... 10:21 AM



Directory Number Configuration - 3

Directory Number Configuration - Microsoft Internet Explorer

File Edit View Favorites Tools Help Links

MLPP Calling Search Space

MLPP No Answer Ring Duration (seconds)

Line 1 on Device SEP000BBEAD4C1C

	Value	Update Shared Device Settings
Display (Internal Caller ID)	<input type="text" value="5004-Polaris"/> Display text for a line appearance is intended for displaying text such as a name instead of a directory number for internal calls. If you specify a number, the person receiving a call may not see the proper identity of the caller.	<input type="checkbox"/>
ASCII Display (Internal Caller ID)	<input type="text" value="5004-Polaris"/>	<input type="checkbox"/>
Line Text Label	<input type="text" value="5004-Polaris"/>	<input type="checkbox"/>
ASCII Line Text Label	<input type="text" value="5004-Polaris"/>	<input type="checkbox"/>
External Phone Number Mask	<input type="text"/>	<input type="checkbox"/>
Message Waiting Lamp Policy*	<input type="text" value="Use System Policy"/>	<input type="checkbox"/>
Ring Setting (Phone Idle)*	<input type="text" value="Use System Default"/>	<input type="checkbox"/>
Ring Setting (Phone Active)	<input type="text" value="Use System Default"/> Applies to this line when any line on the phone has a call in progress.	<input type="checkbox"/>

Propagate Selected

Multiple Call/Call Waiting Settings on Device SEP000BBEAD4C1C

Note: The range to select the Max Number of calls is: 1-200

Maximum Number of Calls*

Busy Trigger* (Less than or equal to Max. Calls)

Forwarded Call Information Display on Device SEP000BBEAD4C1C

- Caller Name
- Caller Number
- Redirected Number
- Dialed Number

Save Delete Copy Reset Add New

*- indicates required item.

Done Local intranet

Start Tera Term - C... Tera Term - C... 172.20.33.51 -... ORIGIN-v1 - W... Microsoft Outlo... Directory Nu... Untitled - Mes... 10:22 AM



Directory Number Configuration - 4

Directory Number Configuration - Microsoft Internet Explorer

File Edit View Favorites Tools Help

Navigation Cisco Unified CallManager Administration Go

Cisco Unified CallManager Administration For Cisco IP Telecommunication Solutions Logged in as: CCMAdministrator

System Call Routing Media Resources Voice Mail Device Application User Management Bulk Administration Help Log Off

Directory Number Configuration Related Links: Back To Find/List Go

Status
Status: Ready

Note: Changes to Line or Directory Number settings require restart.

Directory Number Information

Directory Number* 5008

Route Partition phones

Description

Alerting Name 5008-Alt-SIP

ASCII Alerting Name 5008-Alt-SIP

Allow Control of Device from CTI

Associated Devices

SEP00170EEE32C6	Edit Device
SEP001120CC61C5	Edit Line Appearance

Dissociate Devices

Directory Number Settings

Voice Mail Profile < None > (Choose <None> to use system default)

Calling Search Space rp_phones

Presence Group* Standard Presence group

AAR Group pbxlab_AAR_group_1

User Hold Audio Source < None >

Network Hold Audio Source < None >

Done

Start Tera Term - COM1... Tera Term - [disco... CCM_5.02 Testing CCM5.02_Polaris... Directory Numb... Tera Term: Log VirusScan On-Acc... Local intranet 11:04 AM



Directory Number Configuration - 5

Directory Number Configuration - Microsoft Internet Explorer

File Edit View Favorites Tools Help Links

Presence Group* Standard Presence group
AAR Group pbxlab_AAR_group_1
User Hold Audio Source < None >
Network Hold Audio Source < None >

Call Forward and Call Pickup Settings

Forward All or Voice Mail Destination [] Calling Search Space tp_phones_rp
Secondary Calling Search Space for Forward All < None > Find
Forward Busy Internal or [] tp_phones_rp
Forward Busy External or [] tp_phones_rp
Forward No Answer Internal or [] tp_phones_rp
Forward No Answer External or [] tp_phones_rp
Forward No Coverage Internal or [] tp_phones_rp
Forward No Coverage External or [] tp_phones_rp
Forward on CTI Failure or [] < None >

No Answer Ring Duration (seconds) []
Call Pickup Group < None >

MLPP Alternate Party Settings

Target (Destination) []
MLPP Calling Search Space < None >
MLPP No Answer Ring Duration (seconds) []

Line 1 on Device SEP001120CC61C5

	Value	Update Shared Device Settings
Display (Internal Caller ID)	5008-Polaris-SIP	<input type="checkbox"/>
Display text for a line appearance is intended for displaying text such as a name instead of a directory number for internal calls. If you specify a number, the person receiving a call may not see the proper identity of the caller.		
ASCII Display (Internal Caller ID)	5008-Polaris-SIP	<input type="checkbox"/>
Line Text Label	5008-Polaris-SIP	<input type="checkbox"/>
ASCII Line Text Label	5008-Polaris-SIP	<input type="checkbox"/>
External Phone	[]	<input type="checkbox"/>

Done Local intranet

Start Tera Term - COM1... Tera Term - [disco... CCM_5.02 Testing Directory Numb... Tera Term: Log VirusScan On-Acc... CCM_5.02_Polaris... 11:06 AM



Directory Number Configuration - 6

Directory Number Configuration - Microsoft Internet Explorer

File Edit View Favorites Tools Help Links

No Answer Ring Duration (seconds)

Call Pickup Group

MLPP Alternate Party Settings

Target (Destination)

MLPP Calling Search Space

MLPP No Answer Ring Duration (seconds)

Line 1 on Device SEP001120CC61C5

	Value	Update Shared Device Settings
Display (Internal Caller ID)	<input type="text" value="5008-Polaris-SIP"/>	<input type="checkbox"/>
Display text for a line appearance is intended for displaying text such as a name instead of a directory number for internal calls. If you specify a number, the person receiving a call may not see the proper identity of the caller.		
ASCII Display (Internal Caller ID)	<input type="text" value="5008-Polaris-SIP"/>	<input type="checkbox"/>
Line Text Label	<input type="text" value="5008-Polaris-SIP"/>	<input type="checkbox"/>
ASCII Line Text Label	<input type="text" value="5008-Polaris-SIP"/>	<input type="checkbox"/>
External Phone Number Mask	<input type="text"/>	<input type="checkbox"/>

Multiple Call/Call Waiting Settings on Device SEP001120CC61C5

Note: The range to select the Max Number of calls is: 1-2

Maximum Number of Calls*

Busy Trigger* (Less than or equal to Max. Calls)

Forwarded Call Information Display on Device SEP001120CC61C5

Caller Name

Caller Number

Redirected Number

Dialed Number

Save Delete Copy Reset Add New

*- indicates required item.

Done Local intranet

Start Tera Term - COM1... Tera Term - [disco... CCM_5.02 Testing Directory Numb... Tera Term: Log VirusScan On-Acc... CCM_5.02_Polaris... 11:06 AM



Service Parameters Configuration - 1

Service Parameter Configuration - Microsoft Internet Explorer

Navigation Cisco Unified CallManager Administration Go

Cisco Unified CallManager Administration For Cisco IP Telecommunication Solutions Logged in as: CCMAdministrator

System Call Routing Media Resources Voice Mail Device Application User Management Bulk Administration Help Log Off

Service Parameter Configuration

Status
Status: Ready

Select Server and Service

Server * 172.20.236.50 (Active)

Service * -- Not Selected --

All parameter -- Not Selected --

- Cisco AMC Service (Active)
- Cisco Bulk Provisioning Service (Inactive)
- Cisco CAR Scheduler (Inactive)
- Cisco CTIManager (Active)
- Cisco CTL Provider (Inactive)
- Cisco CallManager (Active)
- Cisco CallManager Attendant Console Server (Inactive)
- Cisco CallManager SNMP Service (Inactive)
- Cisco Certificate Authority Proxy Function (Inactive)
- Cisco DRF Local (Active)

the Clusterwide group(s).
er available for this service.

- indicates

Done

Start Tera Term - COM1... Tera Term - [disco... CCM_5.02 Testing Service Parame... Tera Term: Log VirusScan On-Acc... Document - Word... 1:15 PM



Service Parameters Configuration - 2

Service Parameter Configuration - Microsoft Internet Explorer

Navigation Cisco Unified CallManager Administration Go

Cisco Unified CallManager Administration For Cisco IP Telecommunication Solutions Logged in as: CCMAdministrator

System Call Routing Media Resources Voice Mail Device Application User Management Bulk Administration Help Log Off

Service Parameter Configuration Related Links: Parameters for All Servers Go

Status
Status: Ready

Select Server and Service
Server * 172.20.236.50 (Active)
Service * Cisco CallManager (Active)
All parameters apply only to the current server except parameters that are in the Clusterwide group(s).

Cisco CallManager (Active) Parameters on server 172.20.236.50 (Active)

Parameter Name	Parameter Value	Suggested Value
CCM Call Throttling		
Code Yellow Entry Latency *	20	20
Code Yellow Exit Latency Calculation *	40	40
Code Yellow Duration *	99999	99999
Max Events Allowed *	2000	2000
System Throttle Sample Size *	10	10
System		
CDR Enabled Flag *	False	False
CDR Log Calls with Zero Duration Flag *	False	False
Digit Analysis Complexity *	StandardAnalysis	StandardAnalysis
Database Debounce Timer *	0	0
Maximum Phone Fallback Queue Depth *	10	10
Maximum Number of Registered Devices *	5000	5000

There are hidden parameters in this group. Click on Advanced button to see hidden parameters.

CDM Terms

https://172.20.236.50:8443/ccmadmin/serviceParamEdit.do#navskip

Start Tera Term - COM1 VT Tera Term - COM2 VT Document - WordPad Service Parameter Co... Local intranet 6:05 PM



Service Parameters Configuration - 3

Service Parameter Configuration - Microsoft Internet Explorer

SIP statistics Periodic update Timer *	2	2
SIP Session Expires Timer *	1800	1800
SIP Trunk TspReq Retry *	2	2

Clusterwide Parameters (Feature - General)

Call Park Display Timer *	15	10
Call Park Reversion Timer *	90	60
Maximum Call Duration Timer *	720	720
Maximum Hold Duration Timer *	360	360
Party Entrance Tone *	True	True
Suppress MOH to Conference Bridge *	True	True
Message Waiting Lamp Policy *	Primary Line - Light and Prompt	Primary Line - Light and Prompt
Message Waiting Indicator Inbound Calling Search Space	tp_phones_rp	
Multiple Tenant MWI Modes *	False	False
MWI Non Message Center Signaling Call Duration *	0	0
Message Waiting Indicator APDU Digit Translation CSS	< None >	
Block OffNet To OffNet Transfer *	False	False
Drop Ad Hoc Conference *	Never	Never

Clusterwide Parameters (Feature - Forward)

Forward Maximum Hop Count *	12	12
Forward No Answer Timer *	12	12
Max Forward Hops to DN *	12	12
Retain Forward Information *	False	False
Forward By Reroute Enabled *	False	False
Transform Forward by Reroute Destination *	True	True
Always Forward Switch Voice Mail Calls *	True	True
Forward By Reroute T1 Timer *	10	10
Include Original Called Info for Q.SIG Call Diversions *	Only after the first diversion	Only after the first diversion

There are hidden parameters in this group. Click on Advanced button to see hidden parameters.

Set TRUE to enable Forward by Reroute



Service Parameters Configuration - 4

Service Parameter Configuration - Microsoft Internet Explorer

File Edit View Favorites Tools Help Links

[Always Forward Switch Voice Mail Calls *](#) True True

[Forward By Reroute T1 Timer *](#) 10 10

[Include Original Called Info for Q.SIG Call Diversions *](#) Only after the first diversion Only after the first diversion

There are hidden parameters in this group. Click on Advanced button to see hidden parameters.

Clusterwide Parameters (Feature - Call Pickup)

[Auto Call Pickup Enabled *](#) False False

[Call Pickup Locating Timer *](#) 1 1

[Call Pickup No Answer Timer *](#) 12 12

Clusterwide Parameters (Feature - Refer)

[Validate Refer-to URI *](#) Validate Except for Anonymous Users Validate Except for Anonymous Users

Clusterwide Parameters (Feature - Replaces)

[Block OffNet To OffNet Replaces *](#) False False

Clusterwide Parameters (Feature - Redirection [3xx])

[Redirection Ring No Answer Reversion Timer *](#) 24 24

[Maximum Redirection Count *](#) 70 70

Clusterwide Parameters (Feature - Multilevel Precedence and Preemption)

[Locations-based MLPP Enable *](#) False False

[Executive Override Call Preemptable *](#) False False

Clusterwide Parameters (Feature - Path Replacement)

[Path Replacement Enabled *](#) False **Set TRUE to enable Path Replacement** False

[Path Replacement on Tromboned Calls *](#) False True

[Start Path Replacement Minimum Delay Time *](#) 1 0

[Start Path Replacement Maximum Delay Time *](#) 5 0

[Path Replacement T1 Timer *](#) 30 30

[Path Replacement T2 Timer *](#) 15 15

[Path Replacement PINX ID](#) 5007

[Path Replacement Calling Search Space](#) rp_phones

Clusterwide Parameters (Feature - Call Back)

Local intranet

Start Tera Term - COM1... Tera Term - [disco... CCM_5.02 Testing Service Parame... Tera Term: Log VirusScan On-Acc... Document - Word... 1:16 PM



Service Parameters Configuration - 5

Service Parameter Configuration - Microsoft Internet Explorer

File Edit View Favorites Tools Help Links

Path Replacement PINX ID	15	
Path Replacement Calling Search Space	5007	
Path Replacement Calling Search Space	rp_phones	

Clusterwide Parameters (Feature - Call Back)

Call Back Enabled Flag *	True	True
Call Back Notification Audio File Name *	CallBack.raw	CallBack.raw
Connection Proposal Type *	No Preference	Connection Retention
Connection Response Type *	Default to Connection Retention	Default to Connection Retention
Call Back Request Protection T1 Timer *	10	10
Call Back Recall T3 Timer *	20	20
Call Back Calling Search Space	tp_phones_rp	
No Path Reservation *	True	True
Set Private Numbering Plan for Call Back *	False	False

Clusterwide Parameters (Route Plan)

Stop Routing on Out of Bandwidth Flag *	False	False
Stop Routing on Unallocated Number Flag *	True	True
Stop Routing on User Busy Flag *	True	True

Clusterwide Parameters (Hunt List)

Stop Hunting on Out of Bandwidth Flag *	False	False
---	-------	-------

Clusterwide Parameters (Service)

Default Network Hold MOH Audio Source ID *	1	1
Default User Hold MOH Audio Source ID *	1	1
Duplex Streaming Enabled *	False	False
Maximum Ad Hoc Conference *	4	4
Maximum MeetMe Conference Unicast *	4	4
Media Exchange Interface Capability Timer *	8	8
Media Exchange Timer *	12	12
Media Exchange Stop Streaming Timer *	8	8

Done Local intranet

Start Tera Term - COM1 VT Tera Term - COM2 VT Document - WordPad Service Parameter Co... 6:08 PM



Service Parameters Configuration - 6

Service Parameter Configuration - Microsoft Internet Explorer

File Edit View Favorites Tools Help

MLPP PRESH To RSVP Priority Mapping	65533	65533
MLPP IMMEDIATE To RSVP Priority Mapping *	65532	65532
MLPP PL_PRIORITY To RSVP Priority Mapping *	65531	65531
MLPP PL_ROUTINE To RSVP Priority Mapping *	65530	65530
RSVP Audio Application ID *	AudioStream	AudioStream
RSVP Video Application ID *	VideoStream	VideoStream
QoS Policy Initialization Timer *	120	120
RSVP Session Manager Initialization Timer *	120	120
RSVP Response Timer *	2	2

TLS Packet Capture Configurations

Packet Capture Enable *	True	False
Packet Capture Max File Size (MB) *	2	2

Clusterwide Parameters (System - Presence)

Presence Subscription Throttling Threshold *	90000	90000
Presence Subscription Resume Threshold *	80	80
Default Inter-Presence Group Subscription *	Disallow Subscription	Disallow Subscription

Clusterwide Parameters (System - Dual Mode Mobility)

Integrated Dual-Mode Feature Enable *	False	False
H1 (Graceful) Handoff Number		
H1 Handoff Number Partition	< None >	
H2 Handoff Number		
H2 Handoff Number Partition	< None >	
Minimum Ring Timer *	2	2
Mobility Cisco CallManager Group	< None >	

Save Set to Default Advanced

- indicates required item.

Done Local intranet 6:09 PM

Start Tera Term - COM1 VT Tera Term - COM2 VT Document - WordPad Service Parameter Co...



Call Forward on No Reply and Busy - 1

Directory Number Configuration - Microsoft Internet Explorer

Navigation Cisco Unified CallManager Administration Go

Cisco Unified CallManager Administration For Cisco IP Telecommunication Solutions Logged in as: CCMAdministrator

System Call Routing Media Resources Voice Mail Device Application User Management Bulk Administration Help Log Off

Directory Number Configuration Related Links: Back To Find/List Go

Status
Status: Ready

Note: Changes to Line or Directory Number settings require restart.

Directory Number Information

Directory Number* 5004

Route Partition phones

Description

Alerting Name 5004-Alt-Pol

ASCII Alerting Name 5004-Alt-Pol

Allow Control of Device from CTI

Associated Devices

SEP000BBEAD4C1C	Edit Device
SEP112233445566	Edit Line Appearance

Dissociate Devices

Directory Number Settings

Voice Mail Profile Unity1 (Choose <None> to use system default)

Calling Search Space rp_phones

Presence Group* Standard Presence group

AAR Group pbxlab_AAR_group_1

User Hold Audio Source < None >

Network Hold Audio Source < None >

Done

Start Tera Term - COM1... Tera Term - COM2... CCM5.02_AAR_Pa... CCM_5.02_Avaya... CCM_5.02 Testing CCM POL~2 - Wor... Directory Numb... Local intranet 11:25 AM



Call Forward on No Reply and Busy - 2

Directory Number Configuration - Microsoft Internet Explorer

File Edit View Favorites Tools Help Links

Presence Group* Standard Presence group
AAR Group pbxlab_AAR_group_1
User Hold Audio Source < None >
Network Hold Audio Source < None >
Auto Answer* Auto Answer Off

Call Forward and Call Pickup Settings

	Voice Mail Destination	Calling Search Space
Forward All	<input type="checkbox"/> or	tp_phones_rp
Secondary Calling Search Space for Forward All		< None > Find
Forward Busy Internal	<input type="checkbox"/> or 2104	tp_phones_rp
Forward Busy External	<input type="checkbox"/> or 2104	tp_phones_rp
Forward No Answer Internal	<input type="checkbox"/> or 2104	tp_phones_rp
Forward No Answer External	<input type="checkbox"/> or 2104	tp_phones_rp
Forward No Coverage Internal	<input type="checkbox"/> or	tp_phones_rp
Forward No Coverage External	<input type="checkbox"/> or	tp_phones_rp
Forward on CTI Failure	<input type="checkbox"/> or	< None >

No Answer Ring Duration (seconds)
Call Pickup Group < None >

MLPP Alternate Party Settings

Target (Destination)
MLPP Calling Search Space < None >
MLPP No Answer Ring Duration (seconds)

Line 1 on Device SEP000BBEAD4C1C

	Value	Update Shared Device Settings
Display (Internal Caller ID)	5004-Polaris	<input type="checkbox"/>
ASCII Display (Internal Caller ID)	5004-Polaris	<input type="checkbox"/>
Line Text Label	5004-Polaris	<input type="checkbox"/>
ASCII Line Text Label	5004-Polaris	<input type="checkbox"/>

Done Local intranet 11:26 AM

Start Tera Term - COM1... Tera Term - COM2... Document - Word... CCM_5.02_Avaya... CCM_5.02 Testing CCMPOL~2 - Wor... Directory Numb...

Call Forward on Busy

Call Forward on No Reply



Call Forward on No Reply and Busy - 3

Directory Number Configuration - Microsoft Internet Explorer

File Edit View Favorites Tools Help Links

MLPP Calling Search Space < None >

MLPP No Answer Ring Duration (seconds)

Line 1 on Device SEP000BBEAD4C1C

	Value	Update Shared Device Settings
Display (Internal Caller ID)	5004-Polaris <small>Display text for a line appearance is intended for displaying text such as a name instead of a directory number for internal calls. If you specify a number, the person receiving a call may not see the proper identity of the caller.</small>	<input type="checkbox"/>
ASCII Display (Internal Caller ID)	5004-Polaris	<input type="checkbox"/>
Line Text Label	5004-Polaris	<input type="checkbox"/>
ASCII Line Text Label	5004-Polaris	<input type="checkbox"/>
External Phone Number Mask		<input type="checkbox"/>
Message Waiting Lamp Policy*	Use System Policy	<input type="checkbox"/>
Ring Setting (Phone Idle)*	Use System Default	<input type="checkbox"/>
Ring Setting (Phone Active)	Use System Default <small>Applies to this line when any line on the phone has a call in progress.</small>	<input type="checkbox"/>

Propagate Selected

Multiple Call/Call Waiting Settings on Device SEP000BBEAD4C1C

Note: The range to select the Max Number of calls is: 1-200

Maximum Number of Calls* 4

Busy Trigger* 1 (Less than or equal to Max. Calls)

Forwarded Call Information Display on Device SEP000BBEAD4C1C

- Caller Name
- Caller Number
- Redirected Number
- Dialed Number

Save Delete Copy Reset Add New

*- indicates required item.

Done Local intranet

Start Tera Term - COM1... Tera Term - COM2... Document - Word... CCM_5.02_Avaya... CCM_5.02_Testing CCMPO~2 - Wor... Directory Numb... 11:26 AM



Automated Alternate Route Configuration - 1

Find and List Automated Alternate Routing Groups - Microsoft Internet Explorer

File Edit View Favorites Tools Help Links

Navigation Cisco Unified CallManager Administration Go

Cisco Unified CallManager Administration For Cisco IP Telecommunication Solutions Logged in as: CCMAdministrator

System Call Routing Media Resources Voice Mail Device Application User Management Bulk Administration Help Log Off

Find and List Automated Alternate Routing Groups

+ [Grid Icon] [Close Icon]

Status
1 records found

Search Options
Find Automated Alternate Routing Group where Name begins with [] [Find] Search Within Results
(name begins with any)

Search Results

Name
<input type="checkbox"/> pbxlab AAR_group_1

Add New Select All Clear All Delete Selected Rows per Page 50

Local intranet

Start Tera Term - COM1... Tera Term - COM2... CCMS_5.02_CallPi... Find and List Au... Cisco Employee C... CCM_5.02_Avaya... CCM_5.02 Testing 6:36 PM



Automated Alternate Route Configuration - 2

Automated Alternate Routing Group Configuration - Microsoft Internet Explorer

File Edit View Favorites Tools Help Links

Navigation Cisco Unified CallManager Administration Go

Cisco Unified CallManager Administration For Cisco IP Telecommunication Solutions Logged in as: CCMAdministrator

System Call Routing Media Resources Voice Mail Device Application User Management Bulk Administration Help Log Off

Automated Alternate Routing Group Configuration Related Links: Back To Find/List Go

Status
Status: Ready

Automated Alternate Routing Group Information
Name* pbxlab_AAR_group_1

Prefix Digits within pbxlab_AAR_group_1
Dial Prefix
pbxlab_AAR_group_1 88

Save Delete Add New

*- indicates required item.

Done Local intranet

Start Tera Term - COM1... Tera Term - COM2... Document - Word... Automated Alte... Cisco Employee C... CCM_5.02_Avaya... CCM_5.02 Testing 6:37 PM



Partition Configuration - 1

Find and List Partitions - Microsoft Internet Explorer

File Edit View Favorites Tools Help Links

Navigation Cisco Unified CallManager Administration Go

Cisco Unified CallManager Administration For Cisco IP Telecommunication Solutions Logged in as:CCMAdministrator

System Call Routing Media Resources Voice Mail Device Application User Management Bulk Administration Help Log Off

Find and List Partitions

+ [Grid Icon] X

Status
3 records found

Search Options
Find partition where Partition Name begins with Find Search Within Results
(name begins with any)

Search Results

	Partition Name	Description
<input type="checkbox"/>	phones	phones
<input type="checkbox"/>	route_p	route_p
<input type="checkbox"/>	translation_p	translation_p

Add New Select All Clear All Delete Selected Rows per Page 50

Done Local intranet

Start Tera Term - COM1... Tera Term - COM2... Document - Word... Find and List Par... Cisco Employee C... CCM_5.02_Avaya... CCM_5.02 Testing 6:37 PM



Partition Configuration - 2

Partition Configuration - Microsoft Internet Explorer

File Edit View Favorites Tools Help

Navigation Cisco Unified CallManager Administration Go

Cisco Unified CallManager Administration For Cisco IP Telecommunication Solutions Logged in as: CCMAdministrator

System Call Routing Media Resources Voice Mail Device Application User Management Bulk Administration Help Log Off

Partition Configuration Related Links: Back To Find/List Go

Status
Status: Ready

Partition Name*
Description
Time Schedule
Time Zone Originating Device Specific Time Zone

Save Delete Reset Add New

*- indicates required item.

Done Local intranet

Start Tera Term - COM1... Tera Term - COM2... Document - Word... Partition Config... Cisco Employee C... CCM_5.02_Avaya... CCM_5.02 Testing 6:38 PM



Partition Configuration - 3

Partition Configuration - Microsoft Internet Explorer

Navigation Cisco Unified CallManager Administration Go

Cisco Unified CallManager Administration For Cisco IP Telecommunication Solutions Logged in as: CCMAdministrator

System Call Routing Media Resources Voice Mail Device Application User Management Bulk Administration Help Log Off

Partition Configuration Related Links: Back To Find/List Go

Status
Status: Ready

Partition Name* route_p

Description route_p

Time Schedule < None >

Time Zone
 Originating Device
 Specific Time Zone Greenwich Standard Time

Save Delete Reset Add New

* - indicates required item.

Done Local intranet

Start Tera Term - COM1... Tera Term - COM2... Document - Word... Partition Config... Cisco Employee C... CCM_5.02_Avaya... CCM_5.02 Testing 6:39 PM



Partition Configuration - 4

Partition Configuration - Microsoft Internet Explorer

File Edit View Favorites Tools Help

Navigation Cisco Unified CallManager Administration Go

Cisco Unified CallManager Administration For Cisco IP Telecommunication Solutions Logged in as: CCMAdministrator

System Call Routing Media Resources Voice Mail Device Application User Management Bulk Administration Help Log Off

Partition Configuration Related Links: Back To Find/List Go

Status
Status: Ready

Partition Name*
Description
Time Schedule
Time Zone Originating Device Specific Time Zone

Save Delete Reset Add New

*- indicates required item.

Done

Start | Tera Term - COM1... | Tera Term - COM2... | Document - Word... | Partition Config... | Cisco Employee C... | CCM_5.02_Avaya... | CCM_5.02 Testing | Local intranet | 6:39 PM



Partition Configuration - 5

Partition Configuration - Microsoft Internet Explorer

File Edit View Favorites Tools Help Links

Navigation Cisco Unified CallManager Administration Go

Cisco Unified CallManager Administration For Cisco IP Telecommunication Solutions Logged in as: CCMAdministrator

System Call Routing Media Resources Voice Mail Device Application User Management Bulk Administration Help Log Off

Partition Configuration Related Links: Back To Find/List Go

Status
Status: Ready

Partition Name*
Description
Time Schedule
Time Zone Originating Device Specific Time Zone

Save Delete Reset Add New

*- indicates required item.

Done Local intranet

Start Tera Term - COM1... Tera Term - COM2... Document - Word... Partition Config... Cisco Employee C... CCM_5.02_Avaya... CCM_5.02 Testing 6:40 PM



Calling Search Space Configuration - 1

Find and List Calling Search Spaces - Microsoft Internet Explorer

File Edit View Favorites Tools Help Links

Navigation Cisco Unified CallManager Administration Go

Cisco Unified CallManager Administration For Cisco IP Telecommunication Solutions Logged in as: CCMAdministrator

System Call Routing Media Resources Voice Mail Device Application User Management Bulk Administration Help Log Off

Find and List Calling Search Spaces

+ [Grid Icon] [Close Icon]

Status
2 records found

Search Options
Find where Name begins with Find Search Within Results
(name begins with any)

Search Results

	CSS Name	Description	Copy
<input type="checkbox"/>	rp_phones		
<input type="checkbox"/>	tp_phones_rp		

Add New Select All Clear All Delete Selected Rows per Page 50

Done Local intranet

Start Tera Term - COM1... Tera Term - COM2... Document - Word... Find and List Cal... Cisco Employee C... CCM_5.02_Avaya... CCM_5.02 Testing 6:42 PM



Calling Search Space Configuration - 2

Calling Search Space Configuration - Microsoft Internet Explorer

File Edit View Favorites Tools Help Links

Navigation Cisco Unified CallManager Administration Go

Cisco Unified CallManager Administration For Cisco IP Telecommunication Solutions Logged in as: CCMAdministrator

System Call Routing Media Resources Voice Mail Device Application User Management Bulk Administration Help Log Off

Calling Search Space Configuration Related Links: Back To Find/List Go

Status
Status: Ready

Calling Search Space Information

Name*
Description

Route Partitions for this Calling Search Space

Available Partitions

Selected Partitions (Ordered by highest priority)

Save Delete Copy Add New

*- indicates required item.

Done Local intranet

Start Tera Term - COM1... Tera Term - COM2... Document - Word... Calling Search S... Cisco Employee C... CCM_5.02_Avaya... CCM_5.02 Testing 6:42 PM



Calling Search Space Configuration - 3

The screenshot shows the Cisco Unified CallManager Administration web interface in Microsoft Internet Explorer. The page title is "Calling Search Space Configuration - Microsoft Internet Explorer". The navigation bar includes "Navigation" and "Cisco Unified CallManager Administration" with a "Go" button. The user is logged in as "CCMAdministrator".

The main content area is titled "Calling Search Space Configuration" and includes a "Related Links" section with a "Back To Find/List" button. Below this, there are icons for save, delete, and add.

Status: Status: Ready

Calling Search Space Information:

- Name*: p_phones_rp
- Description:

Route Partitions for this Calling Search Space:

Available Partitions: [Empty list box]

Selected Partitions (Ordered by highest priority):

- translation_p
- route_p
- phones

Buttons: Save, Delete, Copy, Add New

Info icon: *- indicates required item.

The taskbar at the bottom shows several open applications: Start, Tera Term - COM1..., Tera Term - COM2..., Document - Word..., Calling Search S..., Cisco Employee C..., CCM_5.02_Avaya..., CCM_5.02_Testing, and a clock showing 6:42 PM.



Call Pickup Group Configuration - 1

Find and List Call Pickup Groups - Microsoft Internet Explorer

File Edit View Favorites Tools Help Links

Navigation Cisco Unified CallManager Administration Go

Cisco Unified CallManager Administration For Cisco IP Telecommunication Solutions Logged in as:CCMAdministrator

System Call Routing Media Resources Voice Mail Device Application User Management Bulk Administration Help Log Off

Find and List Call Pickup Groups

+ [Grid Icon] - [Delete Icon]

Status
1 records found

Search Options
Find Call Pickup Group where Call Pickup Group Name begins with Find Search Within Results

Search Results

<input type="checkbox"/>	Call Pickup Group Name	Call Pickup Group Number	Partition	Description	Copy
<input type="checkbox"/>	Path Replacement_PG	5007	phones		

Add New Select All Clear All Delete Selected Rows per Page 50

Done Local intranet

Start Tera Term - COM1... Tera Term - COM2... CCM_5.02_Route... Find and List Cal... Cisco Employee C... CCM_5.02_Avaya... CCM_5.02 Testing 6:34 PM



Call Pickup Group Configuration - 2

Call Pickup Group Configuration - Microsoft Internet Explorer

File Edit View Favorites Tools Help Links

Navigation Cisco Unified CallManager Administration Go

Cisco Unified CallManager Administration For Cisco IP Telecommunication Solutions Logged in as: CCMAdministrator

System Call Routing Media Resources Voice Mail Device Application User Management Bulk Administration Help Log Off

Call Pickup Group Configuration Related Links: Back To Find/List Go

Save Cancel Refresh Add

Status
Status: Ready

Call Pickup Group Information

Call Pickup Group Name* Path_Replacement_PG
Call Pickup Group Number* 5007
Description
Partition phones

Associated Call Pickup Group Information

Find Pickup Numbers by Numbers/Partition

Partition < None >
Call Pickup Group Numbers Contain Find
Available Call Pickup Groups (No Matches Found)
Add to Associated Call Pickup Groups

Current Associated Call Pickup Groups

Reverse Order of Selected Numbers
Selected Call Pickup Groups 5007/phones
Removed Call Pickup Groups

Done

Start Tera Term - COM1... Tera Term - COM2... Document - Word... Call Pickup Grou... Cisco Employee C... CCM_5.02_Avaya... CCM_5.02 Testing Local intranet 6:35 PM



Call Pickup Group Configuration - 3

Call Pickup Group Configuration - Microsoft Internet Explorer

File Edit View Favorites Tools Help Links

Status
Status: Ready

Call Pickup Group Information
Call Pickup Group Name* Path_Replacement_PG
Call Pickup Group Number* 5007
Description
Partition phones

Associated Call Pickup Group Information
Find Pickup Numbers by Numbers/Partition
Partition < None >
Call Pickup Group Numbers Contain Find
Available Call Pickup Groups (No Matches Found)
Add to Associated Call Pickup Groups

Current Associated Call Pickup Groups
Reverse Order of Selected Numbers
Selected Call Pickup Groups 5007/phones
Removed Call Pickup Groups (to be removed when you click Save)

Save Delete Copy Add New

* - indicates required item.

Done Local intranet
Start Tera Term - COM1... Tera Term - COM2... Document - Word... Call Pickup Grou... Cisco Employee C... CCM_5.02_Avaya... CCM_5.02 Testing 6:35 PM



Route Pattern Configuration (Enbloc) - 1

The screenshot displays the Cisco Unified CallManager Administration web interface. The browser window title is "Route Pattern Configuration - Microsoft Internet Explorer". The page header includes "Navigation Cisco Unified CallManager Administration" and "Logged in as: CCMAdministrator". The main navigation menu includes System, Call Routing, Media Resources, Voice Mail, Device, Application, User Management, Bulk Administration, and Help. The "Route Pattern Configuration" section is active, showing a "Status: Ready" message. The "Pattern Definition" section contains the following fields: Route Pattern* (210(1-4)), Route Partition (route_p), Description (To Avaya MV1.1), Numbering Plan (-- Not Selected --), Route Filter (< None >), MLPP Precedence* (Default), Gateway/Route List* (S1/DS1-0@CMM-POLARIS), Route Option (Route this pattern selected), Call Classification* (OnNet), and Authorization Level* (0). The "Calling Party Transformations" section includes fields for Calling Party Transform Mask, Prefix Digits (Outgoing Calls), Calling Line ID Presentation* (Default), and Calling Name Presentation* (Default). The "Connected Party Transformations" section includes Connected Line ID Presentation* (Default). The taskbar at the bottom shows several open applications, including Tera Term, Word, and Cisco Employee C..., along with the system clock showing 6:29 PM.



Route Pattern Configuration (Enbloc) - 2

Route Pattern Configuration - Microsoft Internet Explorer

File Edit View Favorites Tools Help Links

Gateway/Route List * S1/DS1-0@CMM-POLARIS (Edit) Find

Route Option
 Route this pattern
 Block this pattern No Error

Call Classification* OnNet

Allow Device Override Provide Outside Dial Tone Allow Overlap Sending Urgent Priority
 Require Forced Authorization Code

Authorization Level* 0
 Require Client Matter Code

Calling Party Transformations
 Use Calling Party's External Phone Number Mask
Calling Party Transform Mask
Prefix Digits (Outgoing Calls)
Calling Line ID Presentation* Default
Calling Name Presentation* Default

Connected Party Transformations
Connected Line ID Presentation* Default
Connected Name Presentation* Default

Called Party Transformations
Discard Digits < None >
Called Party Transform Mask
Prefix Digits (Outgoing Calls)

ISDN Network-Specific Facilities Information Element
Network Service Protocol -- Not Selected --
Carrier Identification Code
Network Service Service Parameter Name Service Parameter Value
-- Not Selected -- < Not Exist >

Save Delete Copy Add New

*- indicates required item.

Done Local intranet
Start Tera Term - COM1... Tera Term - COM2... Document - Word... Route Pattern C... Cisco Employee C... CCM_5.02_Avaya... CCM_5.02 Testing 6:29 PM



Route Pattern Configuration (Enbloc) - 3

The screenshot displays the Cisco Unified CallManager Administration web interface in Microsoft Internet Explorer. The page title is "Route Pattern Configuration - Microsoft Internet Explorer". The navigation bar includes "Navigation" and "Cisco Unified CallManager Administration" with a "Go" button. The user is logged in as "CCMAdministrator".

The main content area is titled "Route Pattern Configuration" and includes a "Related Links" section with a "Back To Find/List" button. Below this, there are icons for Save, Delete, and Add.

Status: Status: Ready

Pattern Definition

- Route Pattern*: 1600
- Route Partition: route_p
- Description: To Intuity AUDIX on AvayaMV1.1
- Numbering Plan: -- Not Selected --
- Route Filter: < None >
- MLPP Precedence*: Default
- Gateway/Route List*: S1/DS1-0@CMM-POLARIS (Edit) Find
- Route Option:
 - Route this pattern
 - Block this pattern No Error
- Call Classification*: OnNet
- Allow Device Override
- Provide Outside Dial Tone
- Allow Overlap Sending
- Urgent Priority
- Require Forced Authorization Code
- Authorization Level*: 0
- Require Client Matter Code

Calling Party Transformations

- Use Calling Party's External Phone Number Mask
- Calling Party Transform Mask: [Empty]
- Prefix Digits (Outgoing Calls): [Empty]
- Calling Line ID Presentation*: Allowed
- Calling Name Presentation*: Allowed

Connected Party Transformations

- Connected Line ID Presentation*: Allowed

The taskbar at the bottom shows several open applications: Start, Tera Term - COM1..., Tera Term - COM2..., Document - Word..., Route Pattern C..., Cisco Employee C..., CCM_5.02_Avaya..., CCM_5.02 Testing, and Local intranet. The system clock shows 6:30 PM.



Route Pattern Configuration (Enbloc) - 4

Route Pattern Configuration - Microsoft Internet Explorer

File Edit View Favorites Tools Help Links

Gateway/Route List * S1/DS1-0@CMM-POLARIS (Edit) Find

Route Option
 Route this pattern
 Block this pattern No Error

Call Classification* OnNet

Allow Device Override Provide Outside Dial Tone Allow Overlap Sending Urgent Priority
 Require Forced Authorization Code

Authorization Level* 0

Require Client Matter Code

Calling Party Transformations

Use Calling Party's External Phone Number Mask

Calling Party Transform Mask

Prefix Digits (Outgoing Calls)

Calling Line ID Presentation* Allowed

Calling Name Presentation* Allowed

Connected Party Transformations

Connected Line ID Presentation* Allowed

Connected Name Presentation* Allowed

Called Party Transformations

Discard Digits < None >

Called Party Transform Mask

Prefix Digits (Outgoing Calls)

ISDN Network-Specific Facilities Information Element

Network Service Protocol -- Not Selected --

Carrier Identification Code

Network Service	Service Parameter Name	Service Parameter Value
-- Not Selected --	< Not Exist >	

Save Delete Copy Add New

*- indicates required item.

Done Local intranet

Start Tera Term - COM1... Tera Term - COM2... Document - Word... Route Pattern C... Cisco Employee C... CCM_5.02_Avaya... CCM_5.02 Testing 6:31 PM



Route Pattern Configuration (Overlap) - 1

The screenshot displays the Cisco Unified CallManager Administration web interface. The browser window title is "Route Pattern Configuration - Microsoft Internet Explorer". The page header includes "Navigation Cisco Unified CallManager Administration" and "Logged in as: CCMAdministrator". The main navigation menu includes "System", "Call Routing", "Media Resources", "Voice Mail", "Device", "Application", "User Management", "Bulk Administration", and "Help". The "Route Pattern Configuration" section is active, showing a "Status: Ready" message. The configuration form is divided into three sections: "Pattern Definition", "Calling Party Transformations", and "Connected Party Transformations".

Pattern Definition

- Route Pattern*: 2
- Route Partition: route_p
- Description: overlap sending to Avaya MV1.1
- Numbering Plan: -- Not Selected --
- Route Filter: < None >
- MLPP Precedence*: Default
- Gateway/Route List*: S1/DS1-0@CMM-POLARIS (Edit) Find
- Route Option: Route this pattern, Block this pattern (No Error)
- Call Classification*: OnNet
- Allow Device Override, Provide Outside Dial Tone, Allow Overlap Sending, Urgent Priority
- Require Forced Authorization Code
- Authorization Level*: 0
- Require Client Matter Code

Calling Party Transformations

- Use Calling Party's External Phone Number Mask
- Calling Party Transform Mask: [Empty]
- Prefix Digits (Outgoing Calls): [Empty]
- Calling Line ID Presentation*: Default
- Calling Name Presentation*: Default

Connected Party Transformations

- Connected Line ID Presentation*: Default

The taskbar at the bottom shows several open applications: "Tera Term - COM1...", "Tera Term - COM2...", "Document - Word...", "Route Pattern C...", "Cisco Employee C...", "CCM_5.02_Avaya...", "CCM_5.02 Testing", and the system clock shows 6:33 PM.



Route Pattern Configuration (Overlap) - 2

Route Pattern Configuration - Microsoft Internet Explorer

File Edit View Favorites Tools Help Links

Gateway/Route List * S1/DS1-0@CMM-POLARIS (Edit) Find

Route Option
 Route this pattern
 Block this pattern No Error

Call Classification* OnNet

Allow Device Override Provide Outside Dial Tone Allow Overlap Sending Urgent Priority
 Require Forced Authorization Code

Authorization Level* 0

Require Client Matter Code

Calling Party Transformations

Use Calling Party's External Phone Number Mask

Calling Party Transform Mask

Prefix Digits (Outgoing Calls)

Calling Line ID Presentation* Default

Calling Name Presentation* Default

Connected Party Transformations

Connected Line ID Presentation* Default

Connected Name Presentation* Default

Called Party Transformations

Discard Digits PreDot

Called Party Transform Mask

Prefix Digits (Outgoing Calls)

ISDN Network-Specific Facilities Information Element

Network Service Protocol -- Not Selected --

Carrier Identification Code

Network Service	Service Parameter Name	Service Parameter Value
-- Not Selected --	< Not Exist >	

Save Delete Copy Add New

i *- indicates required item.

Done Local intranet

Start Tera Term - COM1... Tera Term - COM2... Document - Word... Route Pattern C... Cisco Employee C... CCM_5.02_Avaya... CCM_5.02 Testing 6:33 PM



Connected Name and Number Restriction (CONR, COLR) - 1

Translation Pattern Configuration

The screenshot displays the Cisco Unified CallManager Administration web interface. The page title is "Find and List Translation Patterns". The navigation menu includes "Cisco Unified CallManager Administration" and "Go". The user is logged in as "CCMAdministrator". The main content area is titled "Find and List Translation Patterns" and shows a search results table with one entry:

Translation Pattern	Partition	Description	Route Filter	Copy
<input type="checkbox"/> 509X	translation_p	Translation Pattern for Incoming Calls		

Below the table are buttons for "Add New", "Select All", "Clear All", and "Delete Selected". The "Rows per page" is set to 50. The search options section shows "Find Translation patterns where" with a dropdown menu set to "Pattern" and "begins with" set to an empty field. The search criteria is "(numplan.dnorpattern begins with any)".



Connected Name and Number Restriction (CONR, COLR) - 2

Translation Pattern Configuration

The screenshot displays the Cisco Unified CallManager Administration web interface in Microsoft Internet Explorer. The page title is "Translation Pattern Configuration - Microsoft Internet Explorer". The navigation bar shows "Cisco Unified CallManager Administration" and "Logged in as: CCMAdministrator". The main content area is titled "Translation Pattern Configuration" and includes a "Status" section showing "Status: Ready".

Pattern Definition

- Translation Pattern: 509X
- Partition: translation_p
- Description: Translation Pattern for Incoming Calls
- Numbering Plan: < None >
- Route Filter: < None >
- MLPP Precedence*: Default
- Calling Search Space: tp_phones_tp
- Route Option: Route this pattern, Block this pattern (No Error)
- Provide Outside Dial Tone, Urgent Priority

Calling Party Transformations

- Use Calling Party's External Phone Number Mask
- Calling Party Transform Mask: [Empty]
- Prefix Digits (Outgoing Calls): [Empty]
- Calling Line ID Presentation*: Default
- Calling Name Presentation*: Default

Connected Party Transformations

- Connected Line ID Presentation*: Restricted
- Connected Name Presentation*: Restricted

Called Party Transformations

- Discard Digits: < None >
- Called Party Transform Mask: [Empty]

The taskbar at the bottom shows several open applications: Start, Translation Patt..., Tera Term - [disco..., Tera Term: Log, Tera Term - COM1 VT, CCM_5.02 Testing, CCM_5.02_Avaya..., Document - WordPad, and Local intranet. The system clock shows 11:03 AM.



Calling Name and Number Restriction (CNIR and CLIR) - 1

The screenshot displays the Cisco Unified CallManager Administration web interface in Microsoft Internet Explorer. The page title is "Route Pattern Configuration - Microsoft Internet Explorer". The navigation bar includes "Navigation | Cisco Unified CallManager Administration" and "Go". The main header shows "Cisco Unified CallManager Administration For Cisco IP Telecommunication Solutions" and "Logged in as: CCMAdministrator". The breadcrumb trail is "System > Call Routing > Media Resources > Voice Mail > Device > Application > User Management > Bulk Administration > Help". A "Log Off" button is visible. The main content area is titled "Route Pattern Configuration" and includes a "Related Links: Back To Find/List" button. The configuration form is divided into three sections:

- Status:** Status: Ready
- Pattern Definition:**
 - Route Pattern*: 210(1-4)
 - Route Partition: route_p
 - Description: To Avaya MV1.1
 - Numbering Plan: -- Not Selected --
 - Route Filter: < None >
 - MLPP Precedence*: Default
 - Gateway/Route List*: S2/DS1-0@CMM-POLARIS (Edit) Find
 - Route Option: Route this pattern, Block this pattern (No Error)
 - Call Classification*: OnNet
 - Checkboxes: Allow Device Override, Provide Outside Dial Tone, Allow Overlap Sending, Urgent Priority, Require Forced Authorization Code, Require Client Matter Code
 - Authorization Level*: 0
- Calling Party Transformations:**
 - Use Calling Party's External Phone Number Mask:
 - Calling Party Transform Mask: [Empty]
 - Prefix Digits (Outgoing Calls): [Empty]
 - Calling Line ID Presentation*: Restricted
 - Calling Name Presentation*: Restricted
- Connected Party Transformations:**
 - Connected Line ID Presentation*: Default

The taskbar at the bottom shows several open applications: Start, Route Pattern C..., Tera Term - [disco..., Tera Term: Log, Tera Term - COM1 VT, CCM_5.02 Testing, CCM_5.02_Avaya..., Document - WordPad, and Local intranet. The system clock shows 11:05 AM.



Calling Name and Number Restriction (CNIR and CLIR) - 2

Route Pattern Configuration - Microsoft Internet Explorer

File Edit View Favorites Tools Help Links

Gateway/Route List * S2/DS1-0@CMM-POLARIS (Edit) Find

Route Option
 Route this pattern
 Block this pattern No Error

Call Classification* OnNet

Allow Device Override Provide Outside Dial Tone Allow Overlap Sending Urgent Priority
 Require Forced Authorization Code

Authorization Level* 0

Require Client Matter Code

Calling Party Transformations

Use Calling Party's External Phone Number Mask

Calling Party Transform Mask

Prefix Digits (Outgoing Calls)

Calling Line ID Presentation* Restricted

Calling Name Presentation* Restricted

Connected Party Transformations

Connected Line ID Presentation* Default

Connected Name Presentation* Default

Called Party Transformations

Discard Digits < None >

Called Party Transform Mask

Prefix Digits (Outgoing Calls)

ISDN Network-Specific Facilities Information Element

Network Service Protocol -- Not Selected --

Carrier Identification Code

Network Service	Service Parameter Name	Service Parameter Value
-- Not Selected --	< Not Exist >	

Save Delete Copy Add New

*- indicates required item.

Done Local intranet

Start Route Pattern C... Tera Term - [disco... Tera Term: Log Tera Term - COM1 VT CCM_5.02 Testing CCM_5.02_Avaya... Document - WordPad 11:05 AM



Voice Mail Port Configuration - 1

Find and List Voice Mail Ports - Microsoft Internet Explorer

File Edit View Favorites Tools Help

Navigation Cisco Unified CallManager Administration Go

Cisco Unified CallManager Administration For Cisco IP Telecommunication Solutions Logged in as: CCMAdministrator

System Call Routing Media Resources Voice Mail Device Application User Management Bulk Administration Help Log Off

Find and List Voice Mail Ports

Status
4 records found

Search Options
Find Voice Mail Port where Device Name begins with Find Search Within Results
(device.name begins with any)

Search Results

Device Name	Description	Device Pool	SCCP Security Profile	Status	IP Address	Copy
<input type="checkbox"/> CiscoUM1-V11	Unity 1 - port 1	Default	Standard SCCP Profile for Auto Registration	Registered with 172.20.236.50	172.20.236.253	
<input type="checkbox"/> CiscoUM1-V12	Unity 1 - port 1	Default	Standard SCCP Profile for Auto Registration	Registered with 172.20.236.50	172.20.236.253	
<input type="checkbox"/> CiscoUM1-V13	Unity 1 - port 1	Default	Standard SCCP Profile for Auto Registration	Registered with 172.20.236.50	172.20.236.253	
<input type="checkbox"/> CiscoUM1-V14	Unity 1 - port 1	Default	Standard SCCP Profile for Auto Registration	Registered with 172.20.236.50	172.20.236.253	

Add New Select All Clear All Delete Selected Reset Selected Rows per Page 50

Done

Start Tera Term - COM1... Tera Term - [disco... CCM_5.02 Testing Find and List Voi... Tera Term: Log CCM_5.02_Avaya... CCMPOL~3 - Wor... 2:26 PM



Voice Mail Port Configuration - 2

Voice Mail Port Configuration - Microsoft Internet Explorer

File Edit View Favorites Tools Help Links

Navigation Cisco Unified CallManager Administration Go

Cisco Unified CallManager Administration For Cisco IP Telecommunication Solutions Logged in as: CCMAdministrator

System Call Routing Media Resources Voice Mail Device Application User Management Bulk Administration Help Log Off

Voice Mail Port Configuration Related Links: Back To Find/List Go

Save X Refresh +

Status
Status: Ready

Device Information

Registration	Registered with Cisco Unified CallManager 172.20.236.50
IP Address	172.20.236.253
Port Name*	CiscoUM1-VI1
Description	Unity 1 - port 1
Device Pool*	Default
Calling Search Space	rp_phones
AAR Calling Search Space	< None >
Location*	Hub_None
SCCP Phone Security Profile*	Standard SCCP Profile for Auto Registration

Directory Number Information

Directory Number*	6603
Partition	phones
Calling Search Space	rp_phones
AAR Group	< None >
Internal Caller ID Display	VoiceMail
Internal Caller ID Display (ASCII format)	VoiceMail
External Number Mask	

Save Delete Copy Reset Add New

i *- indicates required item.

Done Local intranet

Start Tera Term - COM1... Tera Term - [disco... CCM_5.02 Testing Voice Mail Port ... Tera Term: Log CCM_5.02_Avaya... CCM POL~3 - Wor... 2:26 PM



Message Waiting (MWI) Configuration - 1

Find and List Message Waiting Numbers - Microsoft Internet Explorer

File Edit View Favorites Tools Help Links

Navigation Cisco Unified CallManager Administration Go

Cisco Unified CallManager Administration For Cisco IP Telecommunication Solutions Logged in as:CCMAdministrator

System Call Routing Media Resources Voice Mail Device Application User Management Bulk Administration Help Log Off

Find and List Message Waiting Numbers

+ - X

Status
2 records found

Search Options
Find Message Waiting Numbers where begins with Search Within Results
and where Message Waiting Indicator is
(numplan.dnorpattern begins with any)

Search Results

	Directory Number	Description	Partition	Calling Search Space	Copy
<input type="checkbox"/>	8001		phones	rp_phones	
<input type="checkbox"/>	8002		phones	rp_phones	

Rows per Page

Done Local intranet

Start Tera Term - COM1... Tera Term - [disco... CCM_5.02 Testing Find and List Me... Tera Term: Log CCM_5.02_Avaya... CCM POL~3 - Wor... 2:27 PM



Message Waiting (MWI) Configuration - 2

The screenshot shows the Cisco Unified CallManager Administration web interface in Microsoft Internet Explorer. The page title is "Message Waiting Configuration". The navigation bar includes "Navigation" and "Cisco Unified CallManager Administration" with a "Go" button. The user is logged in as "CCMAdministrator". The main content area is titled "Message Waiting Configuration" and includes a "Status" section showing "Status: Ready". Below this is the "Message Waiting Information" section with the following fields:

- Message Waiting Number*: 3001
- Partition: phones
- Description:
- Message Waiting Indicator*: On Off
- Calling Search Space: rp_phones

At the bottom of the configuration section are buttons for "Save", "Delete", "Copy", and "Add New". A note below the buttons states: "i *- indicates required item." The taskbar at the bottom shows several open applications, including "Tera Term - COM1...", "Tera Term - [disco...", "CCM_5.02 Testing", "Message Waitin...", "Tera Term: Log", "CCM_5.02_Avaya...", and "CCMPOL~3 - Wor...". The system clock shows 2:29 PM.



Message Waiting (MWI) Configuration - 3

The screenshot shows the Cisco Unified CallManager Administration web interface in Microsoft Internet Explorer. The page title is "Message Waiting Configuration". The navigation menu includes "System", "Call Routing", "Media Resources", "Voice Mail", "Device", "Application", "User Management", "Bulk Administration", and "Help". The user is logged in as "CCMAdministrator".

Message Waiting Configuration

Related Links: [Back To Find/List](#) Go

Status
Status: Ready

Message Waiting Information

Message Waiting Number*	0002
Partition	phones
Description	
Message Waiting Indicator*	<input type="radio"/> On <input checked="" type="radio"/> Off
Calling Search Space	rp_phones

Buttons: Save, Delete, Copy, Add New

i *- indicates required item.

Windows taskbar shows: Start, Tera Term - COM1..., Tera Term - [disco..., CCM_5.02 Testing, Message Waitin..., Tera Term: Log, CCM_5.02_Avaya..., CCM POL~3 - Wor..., Local intranet, 2:30 PM



Voice Mail Profile Configuration - 1

Find and List Voice Mail Profiles - Microsoft Internet Explorer

File Edit View Favorites Tools Help

Navigation Cisco Unified CallManager Administration Go

Cisco Unified CallManager Administration For Cisco IP Telecommunication Solutions Logged in as: CCMAdministrator

System Call Routing Media Resources Voice Mail Device Application User Management Bulk Administration Help Log Off

Find and List Voice Mail Profiles

Status
5 records found

Search Options
Find Voice Mail Profile where Voice Mail Profile Name begins with Find Search Within Results
(voicemailprofile.name begins with any)

Search Results

	Name	Description	Pilot	Calling Search Space	Copy
<input type="checkbox"/>	Audix	Audix voicemail on Avaya PBX	1600	rp_phones	
<input type="checkbox"/>	Default	Default voice messaging profile	5100	rp_phones	
<input type="checkbox"/>	NoVoiceMail	No Voice Mail			
<input type="checkbox"/>	Unity1	Unity1 voicemail	4050	tp_phones_rp	
<input type="checkbox"/>	iDivert_test		2104	rp_phones	

Add New Select All Clear All Delete Selected Rows per Page 50

Done

Start Tera Term - COM1... Tera Term - [disco... CCM_5_02 Testing Find and List Voi... Tera Term: Log CCM_5_02_Avaya... CCMPOL~3 - Wor... 2:32 PM



Voice Mail Profile Configuration - 2

The screenshot displays the Cisco Unified CallManager Administration web interface. The browser window title is "Voice Mail Profile Configuration - Microsoft Internet Explorer". The page header includes "Navigation | Cisco Unified CallManager Administration" and "Logged in as: CCMAdministrator". A navigation menu contains "System", "Call Routing", "Media Resources", "Voice Mail", "Device", "Application", "User Management", "Bulk Administration", and "Help". The main content area is titled "Voice Mail Profile Configuration" and shows the configuration for a profile named "Audix".

Status: Ready

Voice Mail Profile Information

Voice Mail Profile: Audix (used by 0 devices)

Voice Mail Profile Name*: Audix

Description: Audix voicemail on Avaya PBX

Voice Mail Pilot**: 1600/rp_phones

Voice Mail Box Mask: [Empty field]

Make this the default Voice Mail Profile for the System

Buttons: Save, Delete, Copy, Reset, Add New

Info: *- indicates required item.
**- The Voice Mail Pilot is comprised of the Voice Mail Pilot Number and it's corresponding Calling Search Space Name (< Voice Mail Pilot Number >/< Calling Search Space >).

Taskbar: Start, Tera Term - COM1..., Tera Term - [disco..., CCM_5.02 Testing, Voice Mail Profil..., Tera Term: Log, CCM_5.02_Avaya..., CCMPOL~3 - Wor..., 2:33 PM



Voice Mail Profile Configuration - 3

The screenshot displays the Cisco Unified CallManager Administration web interface in Microsoft Internet Explorer. The page title is "Voice Mail Profile Configuration - Microsoft Internet Explorer". The navigation bar includes "Cisco Unified CallManager Administration" and "Logged in as: CCMAdministrator". The main menu contains "System", "Call Routing", "Media Resources", "Voice Mail", "Device", "Application", "User Management", "Bulk Administration", and "Help". The "Voice Mail Profile Configuration" section is active, showing a "Status: Ready" message. Below this, the "Voice Mail Profile Information" section contains the following fields:

- Voice Mail Profile: Unity1 (used by 42 devices)
- Voice Mail Profile Name*: Unity1
- Description: Unity1 voicemail
- Voice Mail Pilot**: 4050/tp_phones_rp
- Voice Mail Box Mask: (empty)

A checkbox labeled "Make this the default Voice Mail Profile for the System" is checked. Below the form are buttons for "Save", "Delete", "Copy", "Reset", and "Add New". Informational text at the bottom explains that "*" indicates a required item and "**" indicates the Voice Mail Pilot is composed of the Voice Mail Pilot Number and its corresponding Calling Search Space Name (< Voice Mail Pilot Number >/< Calling Search Space >).

The Windows taskbar at the bottom shows several open applications: Start, Tera Term - COM1..., Tera Term - [disco..., CCM_5.02 Testing, Voice Mail Profil..., Tera Term: Log, CCM_5.02_Avaya..., CCMPOL~3 - Wor..., and a clock showing 2:37 PM.



Voice Mail Pilot Configuration - 1

Find and List Voice Mail Pilots - Microsoft Internet Explorer

File Edit View Favorites Tools Help Links

Navigation Cisco Unified CallManager Administration Go

Cisco Unified CallManager Administration For Cisco IP Telecommunication Solutions Logged in as: CCMAdministrator

System Call Routing Media Resources Voice Mail Device Application User Management Bulk Administration Help Log Off

Find and List Voice Mail Pilots

+ [Grid Icon] [Close Icon]

Status
7 records found

Search Options
Find Voice Mail Pilots where Voice Mail Pilot Number begins with **Find**

Search Results

Pilot Number	Description	Calling Search Space
<input type="checkbox"/>	No Voice Mail Default	
<input type="checkbox"/> 1600	Audix	rp_phones
<input type="checkbox"/> 2104		rp_phones
<input checked="" type="checkbox"/> 4050	Unity1	tp_phones_rp
<input type="checkbox"/> 5050	Octel 200	rp_phones
<input type="checkbox"/> 5100	Octel 250	rp_phones

Add New Select All Clear All Delete Selected Rows per Page 50

Done Local intranet

Start Tera Term - COM1... Tera Term - [disco... CCM_5_02 Testing Find and List Voi... Tera Term: Log CCM_5_02_Avaya... CCM_Polaris_5_Call... 2:21 PM



Voice Mail Pilot Configuration - 2

The screenshot shows the Cisco Unified CallManager Administration web interface in Microsoft Internet Explorer. The page title is "Voice Mail Pilot Configuration - Microsoft Internet Explorer". The navigation bar includes "Navigation" and "Cisco Unified CallManager Administration" with a "Go" button. The user is logged in as "CCMAdministrator". The main navigation menu includes "System", "Call Routing", "Media Resources", "Voice Mail", "Device", "Application", "User Management", "Bulk Administration", and "Help". The "Voice Mail Pilot Configuration" page is active, showing a "Status: Ready" message and a "Voice Mail Pilot Information" section. The information section contains the following fields: "Voice Mail Pilot Number" (1600), "Calling Search Space" (rp_phones), and "Description" (Audix). There is a checkbox for "Make this the default Voice Mail Pilot for the system" which is unchecked. Below the information section are "Save", "Delete", and "Add New" buttons. A note at the bottom states "* - indicates required item." The taskbar at the bottom shows several open applications, including "Tera Term", "CCM_5.02 Testing", "Voice Mail Pilot ...", and "CCM_5.02_Avaya...". The system clock shows 2:24 PM.



Voice Mail Pilot Configuration - 3

The screenshot shows the Cisco Unified CallManager Administration web interface in Microsoft Internet Explorer. The page title is "Voice Mail Pilot Configuration - 3". The navigation bar includes "Navigation" and "Cisco Unified CallManager Administration" with a "Go" button. The user is logged in as "CCMAdministrator". The main menu includes "System", "Call Routing", "Media Resources", "Voice Mail", "Device", "Application", "User Management", "Bulk Administration", and "Help". The "Voice Mail Pilot Configuration" section is active, showing a "Status: Ready" message. Below this, the "Voice Mail Pilot Information" section contains the following fields: "Voice Mail Pilot Number" (4050), "Calling Search Space" (tp_phones_rp), and "Description" (Unity1). A checkbox "Make this the default Voice Mail Pilot for the system" is checked. At the bottom of the form are "Save", "Delete", and "Add New" buttons. A note below the form states: "i *- indicates required item." The Windows taskbar at the bottom shows several open applications, including "Tera Term", "CCM_5.02 Testing", and "Voice Mail Pilot ...". The system clock shows 2:25 PM.



CallBack Softkey Template - 1

Find and List Softkey Templates - Microsoft Internet Explorer

File Edit View Favorites Tools Help Links

Navigation Cisco Unified CallManager Administration Go

Cisco Unified CallManager Administration For Cisco IP Telecommunication Solutions Logged in as:CCMAdministrator

System Call Routing Media Resources Voice Mail Device Application User Management Bulk Administration Help Log Off

Find and List Softkey Templates

+ [Grid Icon] [Close Icon]

Status
6 records found

Search Options
Find Softkey Template where Name begins with [] Find Search Within Results
and where Softkey Template is Both
(softkeytemplate.name begins with any)

Search Results

Name	Description	Copy
<input type="checkbox"/> Qsia Custom	Standard Softkey Template for CM QSIG Features	
<input type="checkbox"/> Standard Feature	Standard Softkey Template for CM Combined Feature	
<input type="checkbox"/> Standard IPMA Assistant	Standard template for IPMA assistant interface	
<input type="checkbox"/> Standard IPMA Manager	Standard template for IPMA manager interface	
<input type="checkbox"/> Standard IPMA Shared Mode Manager	Standard template for IPMA shared mode manager	
<input type="checkbox"/> Standard User	Standard Softkey Template for CallManager only	

Add New Select All Clear All Delete Selected Rows per Page 50

Done Local intranet

Start Tera Term - COM1... Tera Term - [disco... CCM_5.02 Testing Find and List Sof... Tera Term: Log CCM_5.02_Avaya... CCM POL~3 - Wor... 2:48 PM



CallBack Softkey Template - 2

Softkey Template Configuration - Microsoft Internet Explorer

File Edit View Favorites Tools Help

Navigation Cisco Unified CallManager Administration Go

Cisco Unified CallManager Administration For Cisco IP Telecommunication Solutions Logged in as: CCMAdministrator

System Call Routing Media Resources Voice Mail Device Application User Management Bulk Administration Help Log Off

Softkey Template Configuration Related Links: Configure Softkey Layout Go

Status
Status: Ready

Softkey Template Information

Name*	Qsig Custom
Description	Standard Softkey Template for CM QSIG Features
Applications*	Cisco CallManager

Add Application
Remove Application

Save Delete Copy Add New Reset

*- indicates required item.

Done

Start Tera Term - COM1... Tera Term - [disco... CCM_5.02 Testing Softkey Templa... Tera Term: Log CCM_5.02_Avaya... CCM POL~4 - Wor... 2:48 PM



CallBack Softkey Template - 3

The screenshot shows the Cisco Unified CallManager Administration web interface in Microsoft Internet Explorer. The page title is "Softkey Template Configuration - Microsoft Internet Explorer". The navigation bar includes "Cisco Unified CallManager Administration" and "Logged in as: CCMAdministrator". The main content area is titled "Softkey Template Configuration" and shows the configuration for the "On Hook" call state. The "Softkey Layout Configuration" section displays two columns: "Unselected Softkeys" and "Selected Softkeys (ordered by position)**".

Unselected Softkeys:

- Conference List (ConfList)
- Direct Transfer (DirTrfr)
- Group Pick Up (GPickUp)
- Immediate Divert (IDivert)
- Join (Join)
- Meet Me (MeetMe)
- Other Pickup (oPickup)
- Pick Up (PickUp)
- Quality Report Tool (QRT)
- Remove Last Conference Party (RmLstC)
- Select (Select)
- Undefined (Undefined)
- Video Mode Command (VidMode)

Selected Softkeys (ordered by position):**

- Redial (Redial)
- **NewCall (NewCall)
- End Call (EndCall)
- Forward All (CfwdAll)
- Call Back (CallBack)

Below the configuration area, there are "Save" and "Reset" buttons. A legend indicates that "*" indicates required items and "**" indicates mandatory fields. The taskbar at the bottom shows several open applications, including "Tera Term", "CCM_5_02 Testing", and "Softkey Templa...". The system clock shows 3:15 PM.



CallBack Softkey Template - 4

Softkey Template Configuration - Microsoft Internet Explorer

File Edit View Favorites Tools Help

Navigation Cisco Unified CallManager Administration Go

Cisco Unified CallManager Administration For Cisco IP Telecommunication Solutions Logged in as: CCMAdministrator

System Call Routing Media Resources Voice Mail Device Application User Management Bulk Administration Help Log Off

Softkey Template Configuration Related Links: Softkey Template Configuration Go

Status
Status: Ready

Softkey Layout Configuration
Softkey Template: Qsig Custom
Select a call state to configure: Connected

Unselected Softkeys	Selected Softkeys (ordered by position)**
Immediate Divert (iDivert)	Hold (Hold)
Quality Report Tool (QRT)	**End Call (EndCall)
Undefined (Undefined)	Transfer (Trnsfer)
	Park (Park)
	Conference (Confn)
	Conference List (Conflist)
	Select (Select)
	Join (Join)
	Direct Transfer (DirTrfr)
	Toggle Malicious Call Trace (MCID)
	Remove Last Conference Party (RmLstC)
	Video Mode Command (VidMode)

Save Reset

*- indicates required item.
**- indicates mandatory fields

Done

Start Tera Term - COM1... Tera Term - [disco... CCM_5.02 Testing Softkey Templa... Tera Term: Log CCM_5.02_Avaya... CCMPOL~4 - Wor... 2:49 PM



CallBack Softkey Template - 5

Softkey Template Configuration - Microsoft Internet Explorer

Navigation Cisco Unified CallManager Administration Go

Cisco Unified CallManager Administration For Cisco IP Telecommunication Solutions Logged in as: CCMAdministrator

System Call Routing Media Resources Voice Mail Device Application User Management Bulk Administration Help Log Off

Softkey Template Configuration Related Links: Softkey Template Configuration Go

Status
Status: Ready

Softkey Layout Configuration
Softkey Template: Qsig Custom
Select a call state to configure: On Hold

Unselected Softkeys	Selected Softkeys (ordered by position)**
Immediate Divert (iDivert)	**Resume (Resume)
Undefined (Undefined)	NewCall (NewCall)
	Direct Transfer (DirTrfr)
	Select (Select)
	Join (Join)

Save Reset

*- indicates required item.
**- indicates mandatory fields

Contains commands for working with the selected items.

Start | Tera Term - COM1... | Tera Term - [disco... | CCM_5.02 Testing | Softkey Templa... | Tera Term: Log | CCM_5.02_Avaya... | CCMPOL~4 - Wor... | 2:49 PM



CallBack Softkey Template - 6

The screenshot displays the Cisco Unified CallManager Administration web interface in Microsoft Internet Explorer. The page title is "Softkey Template Configuration - Microsoft Internet Explorer". The navigation bar includes "Navigation" and "Cisco Unified CallManager Administration" with a "Go" button. The user is logged in as "CCMAdministrator".

The main content area is titled "Softkey Template Configuration" and includes a "Related Links" section with a "Softkey Template Configuration" link and a "Go" button. Below this, there is a "Status" section showing "Status: Ready".

The "Softkey Layout Configuration" section is active, showing "Softkey Template: Qsig Custom". A dropdown menu is set to "Ring In". Below this, there are two columns: "Unselected Softkeys" and "Selected Softkeys (ordered by position)**".

Unselected Softkeys	Selected Softkeys (ordered by position)**
Undefined (Undefined)	Answer (Answer)
	Immediate Divert (Divert)

Below the columns are "Save" and "Reset" buttons. A legend indicates that "*" indicates a required item and "**" indicates a mandatory field.

The Windows taskbar at the bottom shows several open applications: Start, Tera Term - COM1..., Tera Term - [disco..., CCM_5.02 Testing, Softkey Templa..., Tera Term: Log, CCM_5.02_Avaya..., CCM POL~4 - Wor..., and a system clock showing 2:56 PM.



CallBack Softkey Template - 7

Softkey Template Configuration - Microsoft Internet Explorer

File Edit View Favorites Tools Help

Navigation Cisco Unified CallManager Administration Go

Cisco Unified CallManager Administration For Cisco IP Telecommunication Solutions Logged in as: CCMAdministrator

System Call Routing Media Resources Voice Mail Device Application User Management Bulk Administration Help Log Off

Softkey Template Configuration Related Links: Softkey Template Configuration Go

Status
Status: Ready

Softkey Layout Configuration
Softkey Template: Qsig Custom
Select a call state to configure: Off Hook

Unselected Softkeys	Selected Softkeys (ordered by position)**
Other Pickup (oPickup)	Redial (Redial)
Undefined (Undefined)	**End Call (EndCall)
	Forward All (CfwdAll)
	Pick Up (PickUp)
	Group Pick Up (GPickUp)
	Meet Me (MeetMe)

Save Reset

*- indicates required item.
**- indicates mandatory fields

Done

Start Tera Term - COM1... Tera Term - [disco... CCM_5.02 Testing Softkey Templa... Tera Term: Log CCM_5.02_Avaya... CCMPOL~4 - Wor... 2:57 PM



CallBack Softkey Template - 8

The screenshot shows the Cisco Unified CallManager Administration web interface. The page title is "Softkey Template Configuration - Microsoft Internet Explorer". The navigation bar includes "Cisco Unified CallManager Administration" and "Logged in as: CCMAdministrator". The main content area is titled "Softkey Template Configuration" and shows the configuration for the "Connected Transfer" call state. The "Softkey Layout Configuration" section displays two columns: "Unselected Softkeys" and "Selected Softkeys (ordered by position)**".

Status: Ready

Softkey Layout Configuration
Softkey Template: Qsig Custom
Select a call state to configure: **Connected Transfer**

Unselected Softkeys	Selected Softkeys (ordered by position)**
Call Back (CallBack)	Undefined (Undefined)
Quality Report Tool (QRT)	End Call (EndCall)
Undefined (Undefined)	**Transfer (Trnsfer)

Buttons: Save, Reset

Legend:
* - indicates required item.
** - indicates mandatory fields



CallBack Softkey Template - 9

Softkey Template Configuration - Microsoft Internet Explorer

File Edit View Favorites Tools Help

Navigation Cisco Unified CallManager Administration Go

Cisco Unified CallManager Administration For Cisco IP Telecommunication Solutions Logged in as: CCMAdministrator

System Call Routing Media Resources Voice Mail Device Application User Management Bulk Administration Help Log Off

Softkey Template Configuration Related Links: Softkey Template Configuration Go

Status: Ready

Softkey Layout Configuration
Softkey Template: Qsig Custom
Select a call state to configure: **Digits After First**

Unselected Softkeys	Selected Softkeys (ordered by position)**
Undefined (Undefined)	**Backward (<<) End Call (EndCall)

Save Reset

*- indicates required item.
**- indicates mandatory fields

Done Local intranet

Start Tera Term - COM1... Tera Term - [disco... CCM_5.02 Testing Softkey Templa... Tera Term: Log CCM_5.02_Avaya... CCM POL~4 - Wor... 3:12 PM



CallBack Softkey Template - 10

The screenshot shows the Cisco Unified CallManager Administration web interface in Microsoft Internet Explorer. The page title is "Softkey Template Configuration - Microsoft Internet Explorer". The navigation bar includes "Cisco Unified CallManager Administration" and "Logged in as: CCMAdministrator". The main content area is titled "Softkey Template Configuration" and shows the "Softkey Layout Configuration" section. The "Softkey Template" is set to "Qsig Custom". A dropdown menu for "Select a call state to configure" is set to "Connected Conference".

Unselected Softkeys

- Quality Report Tool (QRT)
- Undefined (Undefined)

Selected Softkeys (ordered by position)**

- Undefined (Undefined)
- End Call (EndCall)
- **Conference (Confm)

Buttons: Save, Reset

Legend:

- *- indicates required item.
- ** - indicates mandatory fields

Windows taskbar shows: Start, Tera Term - COM1..., Tera Term - [disco..., CCM_5.02 Testing, Softkey Templa..., Tera Term: Log, CCM_5.02_Avaya..., CCM POL~4 - Wor..., Local intranet, 3:12 PM



CallBack Softkey Template - 11

The screenshot shows the Cisco Unified CallManager Administration web interface in Microsoft Internet Explorer. The page title is "Softkey Template Configuration - Microsoft Internet Explorer". The navigation bar includes "Navigation Cisco Unified CallManager Administration" and "Go". The main header displays "Cisco Unified CallManager Administration For Cisco IP Telecommunication Solutions" and "Logged in as: CCMAdministrator". A menu bar contains "System", "Call Routing", "Media Resources", "Voice Mail", "Device", "Application", "User Management", "Bulk Administration", and "Help", along with a "Log Off" button. The main content area is titled "Softkey Template Configuration" and includes a "Related Links" section with "Softkey Template Configuration" and "Go".

Status
Status: Ready

Softkey Layout Configuration
Softkey Template: Qsig Custom
Select a call state to configure: Ring Out

Unselected Softkeys
Undefined (Undefined)

Selected Softkeys (ordered by position)**
**End Call (EndCall)
Direct Transfer (DirTrfr)
Call Back (CallBack)

Buttons: Save, Reset

Legend:
* - indicates required item.
** - indicates mandatory fields

Windows taskbar shows: Done, Start, Tera Term - COM1..., Tera Term - [disco..., CCM_5.02 Testing, Softkey Templa..., Tera Term: Log, CCM_5.02_Avaya..., CCMPOL~4 - Wor..., Local intranet, 3:13 PM



CallBack Softkey Template - 12

Softkey Template Configuration - Microsoft Internet Explorer

File Edit View Favorites Tools Help Links

Navigation Cisco Unified CallManager Administration Go

Cisco Unified CallManager Administration For Cisco IP Telecommunication Solutions Logged in as: CCMAdministrator

System Call Routing Media Resources Voice Mail Device Application User Management Bulk Administration Help Log Off

Softkey Template Configuration Related Links: Softkey Template Configuration Go

Status
Status: Ready

Softkey Layout Configuration
Softkey Template: Qsig Custom
Select a call state to configure: **Off Hook With Feature**

Unselected Softkeys	Selected Softkeys (ordered by position)**
Undefined (Undefined)	Redial (Redial) **End Call (EndCall)

Save Reset

*- indicates required item.
**- indicates mandatory fields

Done Local intranet

Start Tera Term - COM1... Tera Term - [disco... CCM_5_02 Testing Softkey Templa... Tera Term: Log CCM_5_02_Avaya... CCMPOL~4 - Wor... 3:13 PM



CallBack Softkey Template - 13

Softkey Template Configuration - Microsoft Internet Explorer

File Edit View Favorites Tools Help

Navigation Cisco Unified CallManager Administration Go

Cisco Unified CallManager Administration For Cisco IP Telecommunication Solutions Logged in as: CCMAdministrator

System Call Routing Media Resources Voice Mail Device Application User Management Bulk Administration Help Log Off

Softkey Template Configuration Related Links: Softkey Template Configuration Go

Status
Status: Ready

Softkey Layout Configuration
Softkey Template: Qsig Custom
Select a call state to configure: Remote In Use

Unselected Softkeys	Selected Softkeys (ordered by position)**
	Barge (Barge) NewCall (NewCall) Conference Barge (cBarge)

Save Reset

*- indicates required item.
**- indicates mandatory fields

Done

Start Tera Term - COM1... Tera Term - [disco... CCM_5.02 Testing Softkey Templa... Tera Term: Log CCM_5.02_Avaya... CCMPOL~4 - Wor... 3:14 PM



CallBack Softkey Template 14

The screenshot shows the Cisco Unified CallManager Administration web interface in Microsoft Internet Explorer. The browser address bar shows the URL: `https://172.20.235.254/ccadmin/softkeyTemplateLayoutEdit.do?key=2ccfd772-206d-2a91-cf58-49b0dbe383e4&callState=9`. The page title is "Softkey Template Configuration".

The interface includes a navigation menu with options: System, Call Routing, Media Resources, Voice Mail, Device, Application, User Management, Bulk Administration, and Help. The user is logged in as "CCM".

The main content area is titled "Softkey Template Configuration" and shows the following configuration details:

- Status:** Status: Ready
- Softkey Layout Configuration:** Softkey Template: Standard User With Callback. Select a call state to configure: **Off Hook With Feature** (selected).
- Unselected Softkeys:** Undefined (Undefined)
- Selected Softkeys (ordered by position)**:** Redial (Redial), **End Call (EndCall)

At the bottom of the configuration area, there are "Save" and "Reset" buttons.

The Windows taskbar at the bottom shows the Start button, several application icons, and the system tray with the time 9:01 AM.



CallBack Softkey Template 15

Softkey Template Configuration - Microsoft Internet Explorer

File Edit View Favorites Tools Help

Address <https://172.20.235.254/ccadmin/softkeyTemplateLayoutEdit.do?key=2ccfd772-206d-2a91-cf58-49b0dbe383e4&callState=10>

Cisco Unified CallManager Administration For Cisco IP Telecommunication Solutions Logged in as: CCM

System Call Routing Media Resources Voice Mail Device Application User Management Bulk Administration Help

Softkey Template Configuration Related Links: [Softkey Template Configu](#)

Status
Status: Ready

Softkey Layout Configuration
Softkey Template: Standard User With Callback
Select a call state to configure: **Remote In Use**

Unselected Softkeys

- Conference Barge (cBarge)

Selected Softkeys (ordered by position)**

- Barge (Barge)
- NewCall (NewCall)

Save Reset

Done Local intranet 9:01 AM



PSTN Route Pattern Configuration – 1

The screenshot shows the Cisco Unified CallManager Administration web interface in Microsoft Internet Explorer. The page title is "Route Pattern Configuration - Microsoft Internet Explorer". The navigation bar includes "Navigation | Cisco Unified CallManager Administration" and "Go". The main header displays "Cisco Unified CallManager Administration For Cisco IP Telecommunication Solutions" and "Logged in as: CCMadministrator". A menu bar contains "System", "Call Routing", "Media Resources", "Voice Mail", "Device", "Application", "User Management", "Bulk Administration", and "Help", along with a "Log Off" button. The page content is titled "Route Pattern Configuration" and includes a "Related Links: Back To Find/List" button. The configuration is divided into three sections: "Status" (Ready), "Pattern Definition", and "Calling Party Transformations".

Status
Status: Ready

Pattern Definition

- Route Pattern*: 96503646325
- Route Partition: route_p
- Description:
- Numbering Plan: -- Not Selected --
- Route Filter: < None >
- MLPP Precedence*: Default
- Gateway/Route List*: S1/DS1-0@CMM-POLARIS (Edit) Find
- Route Option:
 - Route this pattern
 - Block this pattern No Error
- Call Classification*: OnNet
- Allow Device Override Provide Outside Dial Tone Allow Overlap Sending Urgent Priority
- Require Forced Authorization Code
- Authorization Level*: 0
- Require Client Matter Code

Calling Party Transformations

- Use Calling Party's External Phone Number Mask
- Calling Party Transform Mask:
- Prefix Digits (Outgoing Calls):
- Calling Line ID Presentation*: Default
- Calling Name Presentation*: Default

Connected Party Transformations

- Connected Line ID Presentation*: Default
- Connected Name Presentation*: Default

The taskbar at the bottom shows the Start button, several Tera Term sessions, and the system clock at 12:50 PM.



PSTN Route Pattern Configuration – 2

Route Pattern Configuration - Microsoft Internet Explorer

File Edit View Favorites Tools Help Links

MLPP Precedence* Default

Gateway/Route List* S1/DS1-0@CMM-POLARIS (Edit) Find

Route Option

Route this pattern

Block this pattern No Error

Call Classification* OnNet

Allow Device Override Provide Outside Dial Tone Allow Overlap Sending Urgent Priority

Require Forced Authorization Code

Authorization Level* 0

Require Client Matter Code

Calling Party Transformations

Use Calling Party's External Phone Number Mask

Calling Party Transform Mask

Prefix Digits (Outgoing Calls)

Calling Line ID Presentation* Default

Calling Name Presentation* Default

Connected Party Transformations

Connected Line ID Presentation* Default

Connected Name Presentation* Default

Called Party Transformations

Discard Digits < None >

Called Party Transform Mask

Prefix Digits (Outgoing Calls)

ISDN Network-Specific Facilities Information Element

Network Service Protocol -- Not Selected --

Carrier Identification Code

Network Service	Service Parameter Name	Service Parameter Value
-- Not Selected --	< Not Exist >	

Save Delete Copy Add New

*- indicates required item.

Start Tera Term - [disco... Tera Term: Log Tera Term - COM1 VT Desktop Route Pattern C... CCM_5_02_Avaya... Document - WordPad 12:51 PM



Cisco CMM-T1 Gateway Configuration

```
Current configuration : 4359 bytes
!
version 12.4
no service pad
service timestamps debug datetime msec
service timestamps log datetime msec
no service password-encryption
!
hostname CMM-POLARIS
!
boot-start-marker
boot system bootflash:wscmm-ipvoicek9-mz.124-8.bin
boot-end-marker
!
logging buffered 1000000 debugging
no logging console
!
no aaa new-model
!
resource policy
!
mmi polling-interval 60
mmi auto-configure
no mmi pvc
mmi snmp-timeout 180
ip tcp synwait-time 13
!
ip host CM-MARS 172.20.231.254
ip host CM-VENUS 172.20.214.254
!
isdn switch-type primary-4ess
!
!
controller T1 1/0
framing esf
linecode b8zs
pri-group timeslots 1-24 service mgcp
!
controller T1 1/1
framing esf
linecode b8zs
pri-group timeslots 1-24 service mgcp
!
controller T1 1/2
framing esf
linecode b8zs
pri-group timeslots 1-24 service mgcp
!
controller T1 1/3
framing esf
linecode b8zs
pri-group timeslots 1-24
!
controller T1 1/4
framing esf
linecode b8zs
pri-group timeslots 1-24 service mgcp
```



```
!  
controller T1 1/5  
framing esf  
linecode b8zs  
pri-group timeslots 1-24 service mgcp  
!  
controller E1 2/0  
pri-group timeslots 1-31 service mgcp  
!  
controller E1 2/1  
!  
controller E1 2/2  
!  
controller E1 2/3  
!  
controller E1 2/4  
pri-group timeslots 1-31 service mgcp  
!  
controller E1 2/5  
!  
!  
interface GigabitEthernet1/0  
ip address 172.20.236.170 255.255.255.0  
no ip proxy-arp  
no negotiation auto  
no keepalive  
!  
interface Serial1/0:23  
no ip address  
encapsulation hdlc  
no logging event link-status  
isdn switch-type primary-qsig  
isdn incoming-voice voice  
isdn bind-13 ccm-manager  
isdn bchan-number-order ascending  
no cdp enable  
!  
interface Serial1/1:23  
no ip address  
encapsulation hdlc  
no logging event link-status  
isdn switch-type primary-qsig  
isdn protocol-emulate network  
isdn incoming-voice voice  
isdn T310 120000  
isdn bind-13 ccm-manager  
no cdp enable  
!  
interface Serial1/2:23  
no ip address  
encapsulation hdlc  
no logging event link-status  
isdn switch-type primary-qsig  
isdn incoming-voice voice  
isdn bind-13 ccm-manager  
isdn bchan-number-order ascending  
no cdp enable  
!  
interface Serial1/3:23
```



```
no ip address
encapsulation hdlc
no logging event link-status
isdn switch-type primary-qsig
isdn incoming-voice voice
isdn bchan-number-order ascending
no cdp enable
!
interface Serial1/4:23
no ip address
encapsulation hdlc
no logging event link-status
isdn switch-type primary-qsig
isdn incoming-voice voice
isdn bind-13 ccm-manager
no cdp enable
!
interface Serial1/5:23
no ip address
encapsulation hdlc
no logging event link-status
isdn switch-type primary-qsig
isdn incoming-voice voice
isdn bind-13 ccm-manager
no cdp enable
!
interface Serial2/0:15
no ip address
encapsulation hdlc
no logging event link-status
isdn switch-type primary-qsig
isdn incoming-voice voice
isdn bind-13 ccm-manager
no cdp enable
!
interface Serial2/4:15
no ip address
encapsulation hdlc
no logging event link-status
isdn switch-type primary-qsig
isdn incoming-voice voice
isdn bind-13 ccm-manager
no cdp enable
!
ip default-gateway 172.20.236.1
ip route 0.0.0.0 0.0.0.0 172.20.236.1
!
no ip http server
no ip http secure-server
!
!
control-plane
!
!
voice-port 1/0:23
!
voice-port 1/1:23
!
voice-port 1/2:23
```



```
!  
voice-port 1/3:23  
!  
voice-port 1/4:23  
!  
voice-port 1/5:23  
!  
voice-port 2/0:15  
!  
voice-port 2/4:15  
!  
ccm-manager mgcp  
ccm-manager music-on-hold  
ccm-manager config server 172.20.236.50  
ccm-manager config  
!  
mgcp  
mgcp call-agent 172.20.236.50 2427 service-type mgcp version 0.1  
mgcp dtmf-relay voip codec all mode out-of-band  
mgcp rtp unreachable timeout 1000 action notify  
mgcp modem passthrough voip mode nse  
mgcp package-capability rtp-package  
no mgcp package-capability res-package  
mgcp package-capability sst-package  
mgcp package-capability pre-package  
no mgcp timer receive-rtcp  
mgcp sdp simple  
mgcp fax t38 inhibit  
mgcp rtp payload-type g726r16 static  
!  
mgcp profile default  
!  
!  
!  
!  
dial-peer voice 1 pots  
service mgcpapp  
port 1/0:23  
!  
dial-peer voice 2 pots  
service mgcpapp  
port 1/1:23  
!  
dial-peer voice 3 pots  
service mgcpapp  
port 1/2:23  
!  
dial-peer voice 4 pots  
service mgcpapp  
!  
dial-peer voice 5 pots  
service mgcpapp  
port 1/4:23  
!  
dial-peer voice 6 pots  
service mgcpapp  
port 1/5:23  
!  
!
```



```
line con 0
  transport output all
line vty 0 4
  login
  transport input all
  transport output all
!
!
```

CMM-POLARIS#



PSTN Gateway (Cisco 3745) Configuration

3745E1#sh run

Building configuration...

Current configuration : 1806 bytes

```
!  
version 12.4  
service timestamps debug datetime msec  
service timestamps log datetime msec  
no service password-encryption  
!  
hostname 3745E1  
!  
boot-start-marker  
boot system flash:c3745-ipvoice-mz.124-3.bin  
boot system slot0:C3745-ipvoice-mz.shamu_p2_18  
boot-end-marker  
!  
logging buffered 1000000 debugging  
!  
no aaa new-model  
!  
resource policy  
!  
no network-clock-participate slot 2  
no network-clock-participate slot 3  
no network-clock-participate slot 4  
voice-card 2  
no dspfarm  
!  
voice-card 3  
dspfarm  
!  
voice-card 4  
dspfarm  
!  
ip subnet-zero  
ip cef  
ip tcp synwait-time 13  
!  
!  
!  
!  
isdn switch-type primary-ni  
!  
!  
no voice call carrier capacity active  
!  
!  
!  
!  
!  
!  
!  
!  
!
```



```
!  
!  
controller T1 4/0  
framing esf  
linecode b8zs  
pri-group timeslots 1-24  
!  
controller T1 4/1  
framing sf  
linecode ami  
!  
translation-rule 1  
Rule 1 914085275004 5004  
Rule 2 914085275004 5005  
!  
!  
!  
!  
interface FastEthernet0/0  
ip address 172.20.33.52 255.255.255.0  
duplex auto  
speed auto  
!  
interface FastEthernet0/1  
no ip address  
shutdown  
duplex auto  
speed auto  
!  
interface Serial4/0:23  
no ip address  
isdn switch-type primary-ni  
isdn incoming-voice voice  
no cdp enable  
!  
ip classless  
ip route 0.0.0.0 0.0.0.0 172.20.31.1  
ip route 0.0.0.0 0.0.0.0 FastEthernet0/0  
ip route 0.0.0.0 0.0.0.0 172.20.33.1  
!  
ip http server  
!  
!  
!  
!  
control-plane  
!  
!  
!  
voice-port 2/0/0  
station-id name Yahoo-PSTN  
!  
voice-port 2/0/1  
!  
voice-port 4/0:23  
!  
!  
no mgcp package-capability res-package  
no mgcp package-capability fxr-package
```



```
no mgcp timer receive-rtcp
!  
!  
!  
dial-peer voice 1 pots  
destination-pattern 6503646325  
port 2/0/0  
!  
dial-peer voice 2 pots  
destination-pattern 91408527....  
translate-outgoing called 1  
direct-inward-dial  
port 4/0:23  
!  
!  
line con 0  
line aux 0  
line vty 0 4  
exec-timeout 0 0  
password CISCO  
login  
!  
!  
end  
  
3745E1#
```



Acronyms

Acronym	Definitions
ANF-PR	Additional Network Feature Path Replacement
CCM	Cisco CallManager
CCBS	Call Completion to Busy Subscriber
CCNR	Call Completion on No Reply
CFB	Call Forwarding on Busy
CFNR	Call Forwarding No Reply
CFU	Call Forwarding Unconditional
CLIP	Calling Line (Number) Identification Presentation
CLIR	Calling Line (Number) Identification Restriction
CNIP	Calling Name Identification Presentation
CNIR	Calling Name Identification Restriction
COLP	Connected Line (Number) Identification Presentation
COLR	Connected Line (Number) Identification Restriction
CONP	Connected Name Identification Presentation
CONR	Connected Name Identification Restriction
CT	Call Transfer
MWI	Message Waiting Indicator
PSTN	Public Switched Telephone Network



Important Information

THE SPECIFICATIONS AND INFORMATION REGARDING THE PRODUCTS IN THIS MANUAL ARE SUBJECT TO CHANGE WITHOUT NOTICE. ALL STATEMENTS, INFORMATION, AND RECOMMENDATIONS IN THIS MANUAL ARE BELIEVED TO BE ACCURATE BUT ARE PRESENTED WITHOUT WARRANTY OF ANY KIND, EXPRESS OR IMPLIED. USERS MUST TAKE FULL RESPONSIBILITY FOR THEIR APPLICATION OF ANY PRODUCTS.

IN NO EVENT SHALL CISCO OR ITS SUPPLIERS BE LIABLE FOR ANY INDIRECT, SPECIAL, CONSEQUENTIAL, OR INCIDENTAL DAMAGES, INCLUDING, WITHOUT LIMITATION, LOST PROFITS OR LOSS OR DAMAGE TO DATA ARISING OUT OF THE USE OR INABILITY TO USE THIS MANUAL, EVEN IF CISCO OR ITS SUPPLIERS HAVE BEEN ADVISED OF THE POSSIBILITY OF SUCH DAMAGES.



Corporate Headquarters

Cisco Systems, Inc.
170 West Tasman Drive
San Jose, CA 95134-1706
USA
www.cisco.com
Tel: 408 526-4000
800 553-NETS (6387)
Fax: 408 526-4100

European Headquarters

Cisco Systems International
BV
Haarlerbergpark
Haarlerbergweg 13-19
1101 CH Amsterdam
The Netherlands
www-europe.cisco.com
Tel: 31 0 20 357 1000
Fax: 31 0 20 357 1100

Americas Headquarters

Cisco Systems, Inc.
170 West Tasman Drive
San Jose, CA 95134-1706
USA
www.cisco.com
Tel: 408 526-7660
Fax: 408 527-0883

Asia Pacific Headquarters

Cisco Systems, Inc.
Capital Tower
168 Robinson Road
#22-01 to #29-01
Singapore 068912
www.cisco.com
Tel: +65 317 7777
Fax: +65 317 7799

Cisco Systems has more than 200 offices in the following countries and regions. Addresses, phone numbers, and fax numbers are listed on the Cisco Web site at www.cisco.com/go/offices.

Argentina • Australia • Austria • Belgium • Brazil • Bulgaria • Canada • Chile • China PRC • Colombia • Costa Rica • Croatia • Czech Republic • Denmark • Dubai, UAE • Finland • France • Germany • Greece • Hong Kong SAR • Hungary • India • Indonesia • Ireland • Israel • Italy • Japan • Korea • Luxembourg • Malaysia • Mexico • The Netherlands • New Zealand • Norway • Peru • Philippines • Poland • Portugal • Puerto Rico • Romania • Russia • Saudi Arabia • Scotland • Singapore • Slovakia • Slovenia • South Africa • Spain • Sweden • Switzerland • Taiwan • Thailand • Turkey • Ukraine • United Kingdom • United States • Venezuela • Vietnam • Zimbabwe

© © 2006 Cisco Systems, Inc. All rights reserved.

CCSP, CCVP, the Cisco Square Bridge logo, Follow Me Browsing, and StackWise are trademarks of Cisco Systems, Inc.; Changing the Way We Work, Live, Play, and Learn, and iQuick Study are service marks of Cisco Systems, Inc.; and Access Registrar, Aironet, BPX, Catalyst, CCDA, CCDP, CCIE, CCIP, CCNA, CCNP, Cisco, the Cisco Certified Internetwork Expert logo, Cisco IOS, Cisco Press, Cisco Systems, Cisco Systems Capital, the Cisco Systems logo, Cisco Unity, Enterprise/Solver, EtherChannel, EtherFast, EtherSwitch, Fast Step, FormShare, GigaDrive, GigaStack, HomeLink, Internet Quotient, IOS, IP/TV, iQ Expertise, the iQ logo, iQ Net Readiness Scorecard, LightStream, Linksys, MeetingPlace, MGX, the Networkers logo, Networking Academy, Network Registrar, Packet, PIX, Post-Routing, Pre-Routing, ProConnect, RateMUX, ScriptShare, SlideCast, SMARTnet, The Fastest Way to Increase Your Internet Quotient, and TransPath are registered trademarks of Cisco Systems, Inc. and/or its affiliates in the United States and certain other countries.

All other trademarks mentioned in this document or Website are the property of their respective owners. The use of the word partner does not imply a partnership relationship between Cisco and any other company. (0601R)

Printed in the USA