

Introduction to the Catalyst 3920

This chapter contains the following information about the Catalyst 3920:

- Product Overview
- Physical Characteristics of the Catalyst 3920
- System Architecture

Product Overview

The Catalyst 3920 is a stackable Token Ring switch that provides the following:

- Expandable configuration up to 8 switches
- Low-latency, cut-through switching in a variety of bridging and switching modes
- Configurable ports that can function in half-duplex (HDX) or full-duplex (FDX) modes, as a concentrator or end station
- Transmission priority queues
- Ability to filter frames based on Media Access Control (MAC) address or protocol
- Notification of port errors and beacon situations
- Support for the Cisco Discovery Protocol (CDP)
- Ability to subdivide the switch into virtual LANs (VLANs)
- Support for Simple Network Management Protocol (SNMP)-based management
- Optional remote monitoring (RMON) support
- Ability to monitor port traffic

Interconnection of Switches

The Catalyst 3920 can be used as a standalone switch, or it can be interconnected with up to seven other switches in a ProStack configuration. The ProStack system is formed by connecting two to eight switches with SCSI II-type cables via a ProStack Matrix crossbar switch. A two-switch ProStack may be formed by directly connecting two switches.

In addition, two switches may be interconnected by a number of parallel Token Ring connections, called *TokenChannels*. A *TokenChannel* is two to eight parallel links between Catalyst 3920 switches. The traffic between the switches is shared via the connections.

For more information about stacking Catalyst switches and using *TokenChannels*, refer to the “Interconnecting Catalyst 3920 Switches” chapter.

Bridging Modes

The Catalyst 3920 supports the following bridging and switching modes:

- Source-Route Bridging
- Source-Route Transparent Bridging
- Source-Route Switching

For more information about these bridging modes, refer to the “Understanding Token Ring Switching” appendix.

Token Ring Port Operation

Each of the 24 Token Ring ports can operate in one of the following modes:

- Half-duplex concentrator port—The port is connected to a single station in HDX mode. In this case, the port behaves like an active media access unit (MAU) port for classical Token Ring.
- Half-duplex station emulation—The port is connected to a port on an MAU. In this case, the port behaves like a station connected to a classical Token Ring segment that contains multiple stations.
- Full-duplex concentrator port—The port is connected to a single station in FDX mode.
- Full-duplex station emulation—The port is connected to another Token Ring switch in FDX mode.

The mode of operation can be configured, or it can be automatically sensed when equipment is connected to the port. The media speed (4 or 16 Mbps) can also be configured or automatically sensed in all port modes.

Transmission Priority Queues

To address the needs of delay-sensitive data, such as multimedia, the Token Ring ports of the Catalyst 3920 have two transmit queues, a high-priority queue and a low-priority queue.

The queue for a frame is determined by the value of the priority field in the frame control (FC) byte of the frame. If FC priority is above a configurable level (the default is 3), the frame is put in the high-priority queue. If an output port becomes congested, you can dynamically configure the port to transmit all frames at high priority regardless of the FC byte contents.

The Catalyst 3920 CPU software monitors the size of the output queue at each Token Ring port to minimize the effects of congestion at output ports. When port congestion is detected, the Catalyst 3920 does the following:

- Raises the transmit priority to a higher level for low-priority frames
- Discards the oldest frames when the output queue is almost full

Filtering

Many bridged networks today employ filtering to reduce broadcast traffic, block protocols, and provide simple security. The Catalyst 3920 provides filtering capabilities for the same purpose. You can filter frames based on the following:

- MAC address (source address, destination address)
- Protocol (destination service access point [DSAP]/Subnetwork Access Protocol [SNAP] Type)

MAC address filters and broadcast filters can be applied only at input ports. DSAP and SNAP filters can be applied at input ports and output ports.

Notification of Port Errors and Beacon Situations

The Catalyst 3920 is notified when a serious error, such as signal loss, is detected. The Token Ring port is then instructed to discard all frames in the output queue and to reject new frames.

The Catalyst 3920 is also notified when a Token Ring beacon state is detected on the ring and when it disappears. If the beacon state remains for more than a specified amount of time, the port is instructed to discard all frames in the output queue and to reject new frames. When the beacon state disappears, the port is instructed to once again accept frames.

Cisco Discovery Protocol Support

The CDP support allows the Catalyst 3920 to establish communication with other models of Cisco equipment. CDP support is provided as part of the Cisco IOS software that runs on many types of Cisco equipment.

CDP is a media- and protocol-independent protocol that is intended to be run on Cisco-manufactured equipment including routers, bridges, access servers, and switches. With CDP, Cisco's network management applications and Cisco devices can learn the device type and the SNMP agent address of neighboring devices. This enables applications to send SNMP queries to neighboring devices.

CDP runs on various media that support the SNAP, including LAN, Frame Relay, and Asynchronous Transfer Mode (ATM) media. CDP runs over the data link layer only. Therefore, two systems that support different network-layer protocols can learn about each other.

Each device configured for CDP sends periodic messages to a multicast address. Each device advertises at least one address at which it can receive SNMP messages. The advertisements also contain time-to-live, or holdtime, information, which indicates the length of time a receiving device should hold CDP information before discarding it.

VLANs

The VLAN feature allows you to partition a Catalyst 3920 into multiple VLANs by assigning multiple ports within a single switch or a stacked configuration of switches to the same logical ring number. For each VLAN that you establish, you can configure separate IP, SNMP, and spanning-tree parameters. You can also configure the Catalyst 3920 to bridge traffic between the logical rings of a switch or switch stack.

There are two levels of VLANs supported by the Catalyst 3920. The first level is the Token Ring Concentrator Relay Function (TrCRF). This is the level of VLAN to which the ports are assigned. The second level is the Token Ring Bridge Relay Function (TrBRF). This is the parent VLAN to which TrCRF VLANs are assigned. Traffic is switched between ports in a TrCRF and bridged between TrCRFs in a TrBRF.

The Catalyst 3920 maintains certain configuration information and management statistics on a per VLAN basis. Therefore, when you access VLAN-specific Catalyst 3920 configuration or management panels (such as the Current Spanning Tree Information panel), you will be prompted to specify the desired TrBRF or TrCRF.

Configuration and Management

The Catalyst 3920 provides a series of menu-driven configuration and management panels that you can access via a connected terminal attached to the EIA 232 management port, or from a remote terminal via Telnet. Up to five Telnet sessions are permitted at any one time. In addition, you can do the following:

- Manage the Catalyst 3920 using an SNMP-based manager
- Monitor the Catalyst 3920 using an RMON agent or external monitoring device

SNMP-Based Management

The Catalyst 3920 can be managed via an SNMP manager. The Catalyst 3920 supports twelve Management Information Bases (MIBs). Nine of the MIBs are standard MIBs, which are defined by RFCs and are included with most SNMP management applications. Three of the MIBs are private MIBs and can be obtained from CCO.

The standard MIBs supported are:

- Management Information Base for Network Management of TCP/IP-based Internets: MIB-II (RFC 1213)
- Evolution of Interfaces Group of MIB-II (RFC 1573)
- Definitions of Managed Objects for Bridges (RFC 1493)
- Token Ring Extensions to the Managed Objects for Bridges (RFC 1525)
- IEEE 802.5 Token Ring MIB (RFC 1748)
- RMON MIB/Token Ring Extensions (RFC 1757/1513) partial support
- IEEE 802.5 DTR Concentrator MIB
- IEEE 802.5 DTR MAC MIB

The private MIBs supported are:

- Catalyst 3900 Proprietary MIB
- Cisco VLAN Trunking Protocol MIB
- Cisco Discovery Protocol MIB

Most user configurable variables are supported in either the standard MIBs or private MIBs. Configuration settings, such as port attributes, and operational information, such as address tables, are fully accessible through SNMP. Certain other settings, such as passwords and console settings, cannot be viewed or modified via SNMP for security reasons.

RMON Support

RMON is an industry-standard method for providing network statistics monitoring using SNMP. It also collects fault, performance, and configuration statistics. RMON can monitor continuously, even when communication with the management station is not possible or efficient. It can then notify the management station when an exceptional condition occurs.

In typical SNMP management, the SNMP client has to continuously poll the Catalyst 3920 for fault, performance, and configuration information while waiting for the value to change. This causes increased traffic through the network. With RMON, you can have the switch monitor a particular statistic internally, and when the statistic reaches a threshold, the Catalyst 3920 will send a trap to the client. This monitoring method reduces traffic between the SNMP client and the Catalyst 3920 switch.

As an option, the Catalyst 3920 provides RMON support statistics, history, alarms, and events. It also provides support for the following groups of the Token Ring extensions to the Remote Network Monitoring MIB (RFC 1513):

- **MAC-layer Statistics Group**
A collection of MAC-layer statistics kept for each Token Ring interface, such as the total number of MAC packets received and the number of times the port entered a beaconing state.
- **Promiscuous Statistics Group**
A collection of promiscuous statistics kept for non-MAC packets on each Token Ring interface, such as the total number of good non-MAC frames received that were directed to an LLC broadcast address.
- **Token Ring Ring Station Group**
A collection of statistics and status information associated with each Token Ring station on the local ring. In addition, this group provides status information for each ring being monitored.
- **Token Ring Ring Station Order Group**
A listing of the order of stations on the monitored rings.

You can use an external RMON probe for full RMON support.

Access to RMON data is available only via an SNMP management application that supports RFC 1757 and RFC 1513. You cannot access RMON via the Catalyst 3920 console interface; however, the console statistics provide similar information. For full utilization of RMON data, you should use Cisco's TrafficDirector.

Network Traffic Monitoring

To aid in network management, the Catalyst 3920 allows you to copy traffic from any Token Ring port to the Switched Port Analyzer (SPAN) port. You can then attach an external Token Ring monitor (network analyzer) or RMON probe to the SPAN port. Forwarding to the SPAN port takes place independently of the normal forwarding.

Self-Diagnostics

The Catalyst 3920 performs a self-diagnostic test when it is powered on. The results of these diagnostics are displayed at the console and saved in a diagnostic test results file, which can be viewed later from the console. System information and warning messages are displayed at the console and saved in a message log file, which may also be viewed later from the console. The message log file is not preserved across a system reset.

Physical Characteristics of the Catalyst 3920

The Catalyst 3920 has a CPU planar board with 24 RJ-45 Token Ring ports, one ProStack port, one connector for a Cisco Redundant Power Supply (RPS) unit, and one RS-232 port for management and configuration.

Front of the Catalyst 3920

Figure 1-1 shows the front of the Catalyst 3920.

Figure 1-1 Front View of the Catalyst 3920

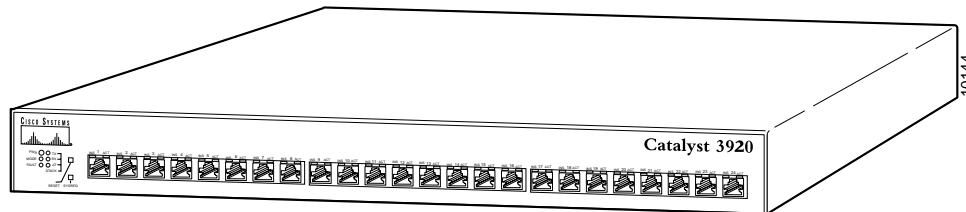

Status and Activity Indicators

The Catalyst 3920 has LEDs that indicate the status and activity of the base switch and its ports. There are three LEDs associated with the switch: power (PWR), mode (MODE), and fault (FLT). There are also three LEDs associated with the stack port: transmit (TX), receive (RX), and attach (AT). There are two LEDs associated with each of the 24 ports: port status and activity. See “Hardware Troubleshooting” for more information about the status indicators.

Reset Button

The Catalyst 3920 has a reset button that is located on the front panel of the switch. Pressing the reset button resets the hardware and software and clears all tables and memory, including the address tables. Pressing the reset button *does not* clear those values stored in NVRAM. This button is recessed to prevent accidental activation.

System Request Button

The System Request (SYSREQ) button is on the front panel below the Reset button. This button causes the System Request Menu to appear on the console attached to the EIA 232 port. The System Request Menu contains options for downloading new software, resetting the switch, and clearing NVRAM.



Caution If this button is pressed for longer than 5 seconds, a download of the main image will be forced. This function should be used only at the direction of service personnel. The button is recessed to prevent accidental activation.

Token Ring Ports

The front of the Catalyst 3920 has 24 shielded RJ-45 connectors for Token Ring connections. These ports allow HDX or FDX connections to other switches, hubs, or end nodes. They support the IBM Cabling System via 150-ohm, shielded twisted-pair (STP) or 100- or 120-ohm unshielded-twisted pair (UTP) via Category 3, 4, or 5 cables.

Back of the Catalyst 3920

Figure 1-2 shows the back of the Catalyst 3920.

Figure 1-2 Back of the Catalyst 3920

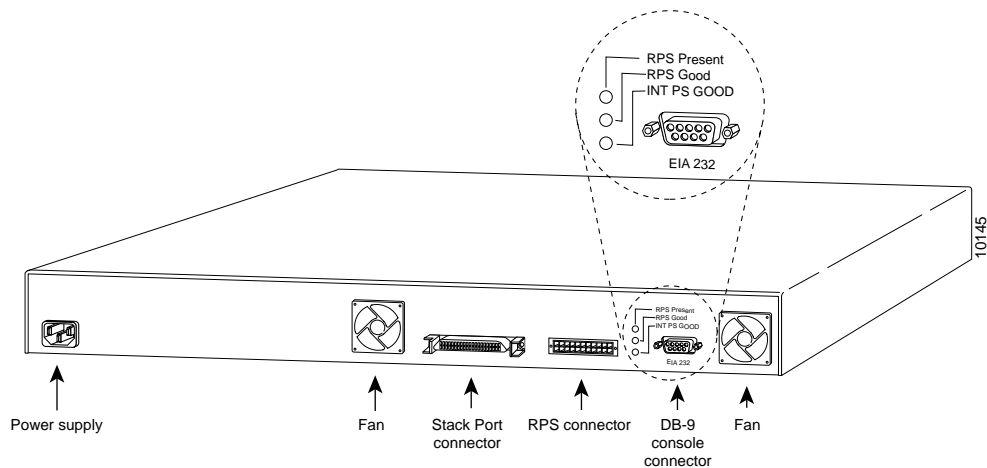

Power Connector

The power connector is located on the back of the Catalyst 3920. There is no power switch.

ProStack Port

The ProStack port located on the back of the switch allows you to stack, or interconnect, switches. This port operates in FDX mode at speeds of 140 Mbps. It switches packets at wire speeds with low forwarding latency. When interconnected via the ProStack port, the members of the stack function as one operational system. You can attach the ProStack port directly to the ProStack port of another Catalyst 3920 or to a ProStack Matrix unit. For more information about stacking Catalyst switches, refer to the “Interconnecting Catalyst 3920 Switches” chapter.

Redundant Power System (RPS) Connector

To help protect your network against power outages, you can connect the Catalyst 3920 to the optional Cisco 600-Watt RPS (PWR600-AC-RPS). The Cisco RPS provides power system redundancy to external devices (such as routers, switches, or hubs). The RPS system includes two fully redundant AC input power modules and four DC output power modules for connection to external devices.

The Cisco RPS supports quasi-redundant and fully redundant configurations in the following ways:

- In a quasi-redundant configuration, the internal power supply of the Catalyst 3900 is considered the main supply. Using a one-to-one cable, you connect a single DC output of the RPS to the Catalyst 3920. The RPS continually monitors the status of the main supply. If the main supply falls below a set voltage, the RPS intervenes and begins providing power to the switch. When the Catalyst 3920 power supply is changed from the main supply to the RPS, the switch will reset.
- In a fully-redundant configuration, all power is supplied by the RPS; the internal power supply of the Catalyst 3920 is not used. Using a two-to-one cable, you connect two of the RPS DC output to the Catalyst 3920. The two-to-one cable is a Y-shaped cable with two connectors at one end of the cable and one connector at the other end. The two connectors at one end of the Y-shaped cable connect to two DC output power modules. The other end of the cable connects to one external device, such as the Catalyst 3920.



Caution If a fully-redundant configuration is used, do not connect the AC power cord to the Catalyst 3920 as this may cause damage to the Catalyst 3920 or the RPS.

There are three status indicators for the RPS: RPS PRESENT, RPS GOOD, INT PS GOOD. See “Hardware Troubleshooting” for more information about the status indicators.

For more information about the Cisco RPS, see the *Cisco RPS Hardware Installation Guide*.

EIA 232 Port

This 9-pin, male management port located on the back of the switch functions as a DTE port.

This port enables attachment of a terminal or terminal emulator that is used to customize the configuration of the switch, monitor switch activity and status, and test the switch. Console access can be either local, by direct attachment to the EIA 232 port, or remote, through a modem connection.

The EIA 232 port automatically detects the baud rate of the terminal to which it is attached.

System Architecture

The internal components that comprise the system architecture of the Catalyst 3920 handle the processing and switching of the frames. The principle components are described in this section.

Figure 1-3 Internal Components of the Catalyst 3920

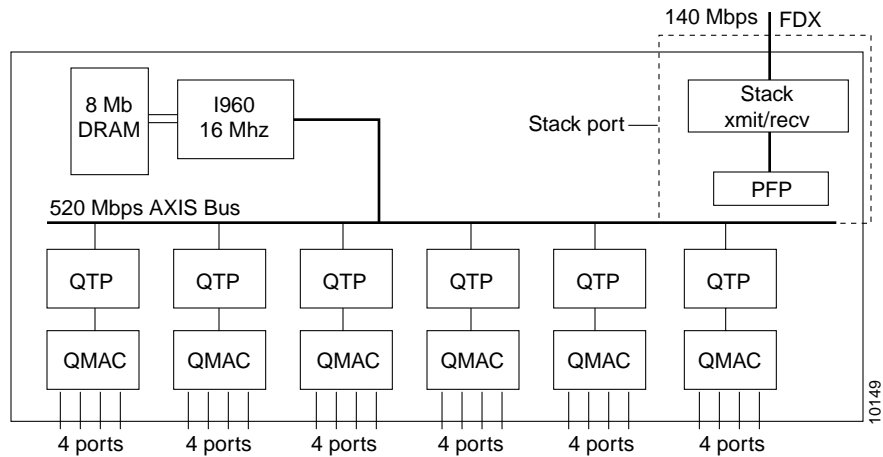

CPU

The CPU performs all of the system initialization and switch table maintenance. It is an Intel 960SA processor, operating at 16 MHz. It has 512 bytes of internal direct-mapped instruction cache and an integrated interrupt controller.

Program Memory DRAM

The program memory dynamic random-access memory (DRAM) is used for program and data storage. It consists of four banks of DRAM providing up to 8 MB of storage.

AXIS Bus

The architecture of the Catalyst 3920 centers around the AXIS bus, a 520 Mbps switching fabric through which all switched ports communicate. The AXIS bus is a partially asynchronous time division multiplexed bus used for switching packets between heterogeneous LAN modules.

Quad Token Ring Port ASIC

The Quad Token Ring Port (QTP) ASIC interfaces directly to the Quad Media Access Controller (QMAC) ASIC and provides the necessary functions for switching directly between the four Token Ring ports connected to each QMAC, or between these and any other port within the switch.

Quad Media Access Controller ASIC

The QMAC ASIC contains four protocol handlers to support four Token Ring physical connections and interfaces directly to the QTP ASIC. It provides support for early token release (ETR) and FDX operation, concentrator and adapter modes for dedicated Token Ring and normal operation, as well as automatic mode detection.

Proprietary Fat Pipe

The Proprietary Fat Pipe is the interface to a ProStack port. The ProStack port operates in FDX mode at speeds of 140Mbps. It switches packets at wire speeds with low forwarding latency. A proprietary 4-byte header is used to allow the members of the stack to function as one operational system.