



# Installation Notes for Catalyst 3750-E and Catalyst 3560-E Switch Fan Modules

---

This document provides the removal and installation procedure for the fan module used with the Catalyst 3750-E and Catalyst 3560-E switches.

For more information about using the fan module, see the *Catalyst 3750-E and Catalyst 3560-E Switch Hardware Installation Guide* on Cisco.com.

For translations of the safety warnings that appear in this publication, see the *Regulatory Compliance and Safety Information for the Catalyst 3750-E and Catalyst 3560-E Switch* that shipped with the switch and also available on Cisco.com.

## Contents

This document includes these sections:

- [Product Overview, page 2](#)
- [Fan Module Installation, page 2](#)
- [Technical Specifications, page 4](#)
- [Related Publications, page 5](#)
- [Obtaining Documentation, page 6](#)
- [Documentation Feedback, page 7](#)
- [Cisco Product Security Overview, page 7](#)
- [Obtaining Technical Assistance, page 8](#)
- [Obtaining Additional Publications and Information, page 9](#)



---

Corporate Headquarters:  
Cisco Systems, Inc., 170 West Tasman Drive, San Jose, CA 95134-1706 USA

© 2006 Cisco Systems, Inc. All rights reserved.

# Product Overview

Table 1 describes the fan module and part number, and Figure 1 shows the fan module.

**Table 1** Fan Module Part Number and Description

Part number	Description
C3K-BLWR-60CFM	Fan module

**Figure 1** Fan Module

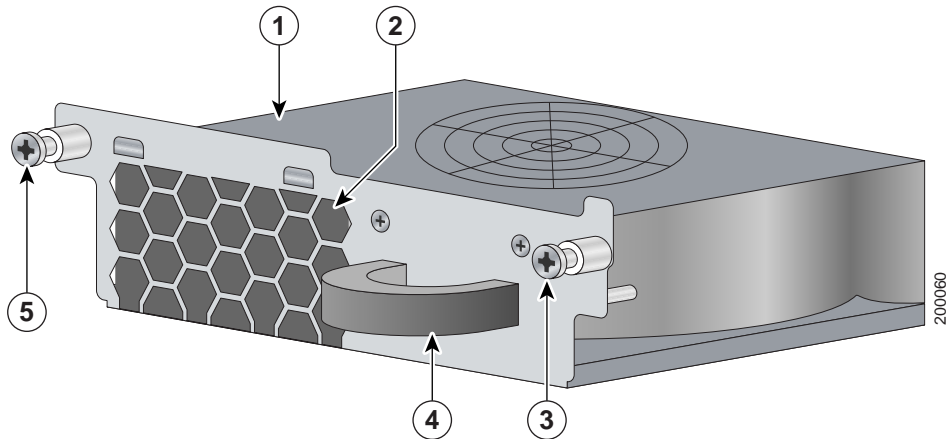

1	Fan module	4	Extraction handle
2	Exhaust vent	5	Captive screw
3	Captive screw		

## Fan Module Installation

This section describes how to remove and install a new or replacement fan module in a Catalyst 3750-E or Catalyst 3560-E switch. See these sections:

- [Tools and Equipment, page 3](#)
- [Installation Guidelines, page 3](#)
- [Installing a Fan Module, page 3](#)

## Tools and Equipment

Obtain these necessary tools and equipment:

Ratcheting torque screwdriver with a number-2 Phillips head that exerts up to 15 pound-force inches (lbf-in.) or 240 ounce-force inches (ozf-in.) of pressure.

## Installation Guidelines

Observe these guidelines when removing or installing a fan module:

- Do not force the fan module into the slot. This can damage the pins on the switch if they are not aligned with the module.
- A fan module that is only partially connected to the switch can disrupt the system operation.
- The switch supports hot swapping of the fan module. You can remove and replace the module without interrupting normal switch operation.
- When replacing the fan module, complete the replacement procedure within 2 minutes to avoid overheating the switch.
- Make sure that all fan module captive screws are tightened before moving the switch.



**Warning**

**Only trained and qualified personnel should be allowed to install, replace, or service this equipment.**  
Statement 1030



**Warning**

**Do not work on the system or connect or disconnect cables during periods of lightning activity.**  
Statement 1001

## Installing a Fan Module

To remove and install a fan module, follow these steps:

**Step 1** Use a number-2 Phillips screwdriver to loosen the two captive screws that secure the fan module to the switch chassis.



**Caution**

You should replace the fan module within 2 minutes to avoid overheating the switch.

**Step 2** Remove the fan module from the fan slot by pulling on the extraction handle.

**Step 3** Insert the new fan module into the fan slot, and gently push the module into the slot (Figure 2). When correctly inserted, the fan module is flush with the switch rear panel.



**Warning**

**Do not reach into a vacant slot or chassis while you install or remove a module or a fan. Exposed circuitry could constitute an energy hazard.** Statement 206

*Figure 2 Inserting the Fan Module*

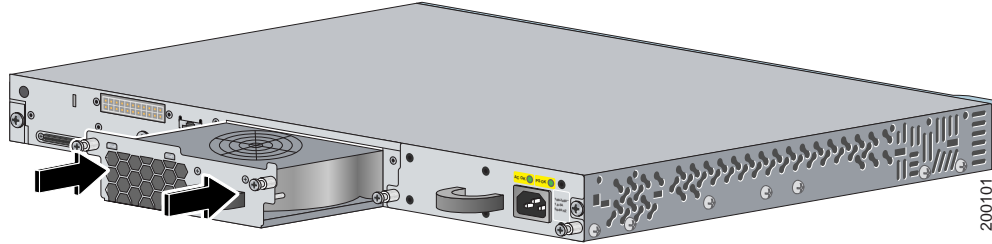

**Step 4** Align the two captive screws with the screw holes in the switch rear panel. Using a ratcheting torque screwdriver, torque each screw to 5 lbf-in. (80 ozf-in.).

## Technical Specifications

*Table 2 Fan Module Environmental and Physical Specifications*

<b>Environmental Ranges</b>	
Operating temperature	23 to 113° F (–5 to 45° C)
Storage temperature	–40 to 158° F (–40 to 70° C)
Relative humidity	10 to 95% (noncondensing)
Altitude	Up to 10,000 ft (3049 m)
<b>Physical Specification</b>	
Dimensions (H x D x W)	1.68 x 6.8 x 5.74 in. (4.27 x 17.27 x 14.58 cm)
<b>Operating Specification</b>	
Airflow	60 cubic feet per minute (CFM)

**Table 3**      **Standards and Certifications**

Description	Specification
Safety Certifications	UL60950-1 C-UL to CAN/CSA 22.2 No.60950-1 TUV/GS to EN 60950-1 CB to IEC 60950-1 with all country deviations AS/NZS 60950-1 CE Marking NOM (through partners and distributors)
Electromagnetic Compatibility Certifications	FCC Part 15 Class A EN55022 Class A (CISPR22) EN55024 (CISPR24) CE VCCI Class A AS/NZS CISPR22 Class A MIC China EMC certifications GOST
Environmental	Reduction of Hazardous Substances (ROHS) 5
Noise Specifications	Office Product Spec: 48dBA at 30 degrees C (refer to ISO 7779)
Telco	CLEI code

## Related Publications

You can order printed copies of documents with a DOC-xxxxxx= number. For more information, see the [“Obtaining Documentation” section on page 6](#).

These documents provide complete information about the switch and are available on Cisco.com:

- *Regulatory Compliance and Safety Information for the Catalyst 3750-E and Catalyst 3560-E Switch* (order number DOC-7817569=)
- *Catalyst 3750-E and Catalyst 3560-E Switch Hardware Installation Guide* (not orderable but available on Cisco.com)
- *Catalyst 3750-E Switch Getting Started Guide* (order number DOC-7817568=)
- *Catalyst 3560-E Switch Getting Started Guide* (order number DOC-7817617=)
- *Release Notes for the Catalyst 3750-E and Catalyst 3560-E Switch* (not orderable but available on Cisco.com)
- *Catalyst 3750-E and Catalyst 3560-E Switch Software Configuration Guide* (not orderable but available on Cisco.com)
- *Catalyst 3750-E and Catalyst 3560-E Switch Command Reference* (not orderable but available on Cisco.com)
- *Catalyst 3750-E and Catalyst 3560-E Switch System Message Guide* (not orderable but available on Cisco.com)
- *Catalyst 3750-E and Catalyst 3560-E Switch Stack Compatibility Guide* (not orderable but available on Cisco.com)

- *Cisco Redundant Power System 2300 Hardware Installation Guide* (order number DOC-7817647=)
- *Cisco Redundant Power System 2300 Compatibility Matrix* (not orderable but available on Cisco.com)

## Obtaining Documentation

Cisco documentation and additional literature are available on Cisco.com. Cisco also provides several ways to obtain technical assistance and other technical resources. These sections explain how to obtain technical information from Cisco Systems.

### Cisco.com

You can access the most current Cisco documentation at this URL:

<http://www.cisco.com/techsupport>

You can access the Cisco website at this URL:

<http://www.cisco.com>

You can access international Cisco websites at this URL:

[http://www.cisco.com/public/countries\\_languages.shtml](http://www.cisco.com/public/countries_languages.shtml)

### Product Documentation DVD

The Product Documentation DVD is a comprehensive library of technical product documentation on a portable medium. The DVD enables you to access multiple versions of installation, configuration, and command guides for Cisco hardware and software products. With the DVD, you have access to the same HTML documentation that is found on the Cisco website without being connected to the Internet. Certain products also have .PDF versions of the documentation available.

The Product Documentation DVD is available as a single unit or as a subscription. Registered Cisco.com users (Cisco direct customers) can order a Product Documentation DVD (product number DOC-DOCDVD= or DOC-DOCDVD=SUB) from Cisco Marketplace at this URL:

<http://www.cisco.com/go/marketplace/>

### Ordering Documentation

Registered Cisco.com users may order Cisco documentation at the Product Documentation Store in the Cisco Marketplace at this URL:

<http://www.cisco.com/go/marketplace/>

Nonregistered Cisco.com users can order technical documentation from 8:00 a.m. to 5:00 p.m. (0800 to 1700) PDT by calling 1 866 463-3487 in the United States and Canada, or elsewhere by calling 011 408 519-5055. You can also order documentation by e-mail at [tech-doc-store-mkpl@external.cisco.com](mailto:tech-doc-store-mkpl@external.cisco.com) or by fax at 1 408 519-5001 in the United States and Canada, or elsewhere at 011 408 519-5001.

# Documentation Feedback

You can rate and provide feedback about Cisco technical documents by completing the online feedback form that appears with the technical documents on Cisco.com.

You can submit comments about Cisco documentation by using the response card (if present) behind the front cover of your document or by writing to the following address:

Cisco Systems  
Attn: Customer Document Ordering  
170 West Tasman Drive  
San Jose, CA 95134-9883

We appreciate your comments.

## Cisco Product Security Overview

Cisco provides a free online Security Vulnerability Policy portal at this URL:

[http://www.cisco.com/en/US/products/products\\_security\\_vulnerability\\_policy.html](http://www.cisco.com/en/US/products/products_security_vulnerability_policy.html)

From this site, you will find information about how to:

- Report security vulnerabilities in Cisco products.
- Obtain assistance with security incidents that involve Cisco products.
- Register to receive security information from Cisco.

A current list of security advisories, security notices, and security responses for Cisco products is available at this URL:

<http://www.cisco.com/go/psirt>

To see security advisories, security notices, and security responses as they are updated in real time, you can subscribe to the Product Security Incident Response Team Really Simple Syndication (PSIRT RSS) feed. Information about how to subscribe to the PSIRT RSS feed is found at this URL:

[http://www.cisco.com/en/US/products/products\\_psirt\\_rss\\_feed.html](http://www.cisco.com/en/US/products/products_psirt_rss_feed.html)

## Reporting Security Problems in Cisco Products

Cisco is committed to delivering secure products. We test our products internally before we release them, and we strive to correct all vulnerabilities quickly. If you think that you have identified a vulnerability in a Cisco product, contact PSIRT:

- For Emergencies only—[security-alert@cisco.com](mailto:security-alert@cisco.com)

An emergency is either a condition in which a system is under active attack or a condition for which a severe and urgent security vulnerability should be reported. All other conditions are considered nonemergencies.

- For Nonemergencies—[psirt@cisco.com](mailto:psirt@cisco.com)

In an emergency, you can also reach PSIRT by telephone:

- 1 877 228-7302
- 1 408 525-6532

**Tip**

We encourage you to use Pretty Good Privacy (PGP) or a compatible product (for example, GnuPG) to encrypt any sensitive information that you send to Cisco. PSIRT can work with information that has been encrypted with PGP versions 2.x through 9.x.

Never use a revoked or an expired encryption key. The correct public key to use in your correspondence with PSIRT is the one linked in the Contact Summary section of the Security Vulnerability Policy page at this URL:

[http://www.cisco.com/en/US/products/products\\_security\\_vulnerability\\_policy.html](http://www.cisco.com/en/US/products/products_security_vulnerability_policy.html)

The link on this page has the current PGP key ID in use.

If you do not have or use PGP, contact PSIRT at the aforementioned e-mail addresses or phone numbers before sending any sensitive material to find other means of encrypting the data.

## Obtaining Technical Assistance

Cisco Technical Support provides 24-hour-a-day award-winning technical assistance. The Cisco Technical Support & Documentation website on Cisco.com features extensive online support resources. In addition, if you have a valid Cisco service contract, Cisco Technical Assistance Center (TAC) engineers provide telephone support. If you do not have a valid Cisco service contract, contact your reseller.

## Cisco Technical Support & Documentation Website

The Cisco Technical Support & Documentation website provides online documents and tools for troubleshooting and resolving technical issues with Cisco products and technologies. The website is available 24 hours a day, at this URL:

<http://www.cisco.com/techsupport>

Access to all tools on the Cisco Technical Support & Documentation website requires a Cisco.com user ID and password. If you have a valid service contract but do not have a user ID or password, you can register at this URL:

<http://tools.cisco.com/RPF/register/register.do>

**Note**

Use the Cisco Product Identification (CPI) tool to locate your product serial number before submitting a web or phone request for service. You can access the CPI tool from the Cisco Technical Support & Documentation website by clicking the **Tools & Resources** link under Documentation & Tools. Choose **Cisco Product Identification Tool** from the Alphabetical Index drop-down list, or click the **Cisco Product Identification Tool** link under Alerts & RMAs. The CPI tool offers three search options: by product ID or model name; by tree view; or for certain products, by copying and pasting **show** command output. Search results show an illustration of your product with the serial number label location highlighted. Locate the serial number label on your product and record the information before placing a service call.



## Submitting a Service Request

Using the online TAC Service Request Tool is the fastest way to open S3 and S4 service requests. (S3 and S4 service requests are those in which your network is minimally impaired or for which you require product information.) After you describe your situation, the TAC Service Request Tool provides recommended solutions. If your issue is not resolved using the recommended resources, your service request is assigned to a Cisco engineer. The TAC Service Request Tool is located at this URL:

<http://www.cisco.com/techsupport/servicerequest>

For S1 or S2 service requests, or if you do not have Internet access, contact the Cisco TAC by telephone. (S1 or S2 service requests are those in which your production network is down or severely degraded.) Cisco engineers are assigned immediately to S1 and S2 service requests to help keep your business operations running smoothly.

To open a service request by telephone, use one of the following numbers:

Asia-Pacific: +61 2 8446 7411 (Australia: 1 800 805 227)

EMEA: +32 2 704 55 55

USA: 1 800 553-2447

For a complete list of Cisco TAC contacts, go to this URL:

<http://www.cisco.com/techsupport/contacts>

## Definitions of Service Request Severity

To ensure that all service requests are reported in a standard format, Cisco has established severity definitions.

Severity 1 (S1)—An existing network is down, or there is a critical impact to your business operations. You and Cisco will commit all necessary resources around the clock to resolve the situation.

Severity 2 (S2)—Operation of an existing network is severely degraded, or significant aspects of your business operations are negatively affected by inadequate performance of Cisco products. You and Cisco will commit full-time resources during normal business hours to resolve the situation.

Severity 3 (S3)—Operational performance of the network is impaired, while most business operations remain functional. You and Cisco will commit resources during normal business hours to restore service to satisfactory levels.

Severity 4 (S4)—You require information or assistance with Cisco product capabilities, installation, or configuration. There is little or no effect on your business operations.

## Obtaining Additional Publications and Information

Information about Cisco products, technologies, and network solutions is available from various online and printed sources.

- The *Cisco Product Quick Reference Guide* is a handy, compact reference tool that includes brief product overviews, key features, sample part numbers, and abbreviated technical specifications for many Cisco products that are sold through channel partners. It is updated twice a year and includes the latest Cisco offerings. To order and find out more about the Cisco Product Quick Reference Guide, go to this URL:

<http://www.cisco.com/go/guide>

- Cisco Marketplace provides a variety of Cisco books, reference guides, documentation, and logo merchandise. Visit Cisco Marketplace, the company store, at this URL:  
<http://www.cisco.com/go/marketplace/>
- *Cisco Press* publishes a wide range of general networking, training and certification titles. Both new and experienced users will benefit from these publications. For current Cisco Press titles and other information, go to Cisco Press at this URL:  
<http://www.ciscopress.com>
- *Internet Protocol Journal* is a quarterly journal published by Cisco Systems for engineering professionals involved in designing, developing, and operating public and private internets and intranets. You can access the Internet Protocol Journal at this URL:  
<http://www.cisco.com/ipj>
- Networking products offered by Cisco Systems, as well as customer support services, can be obtained at this URL:  
<http://www.cisco.com/en/US/products/index.html>
- Networking Professionals Connection is an interactive website for networking professionals to share questions, suggestions, and information about networking products and technologies with Cisco experts and other networking professionals. Join a discussion at this URL:  
<http://www.cisco.com/discuss/networking>
- World-class networking training is available from Cisco. You can view current offerings at this URL:  
<http://www.cisco.com/en/US/learning/index.html>

---

This document is to be used in conjunction with the documents listed in the “Related Publications” section.

CCVP, the Cisco Logo, and the Cisco Square Bridge logo are trademarks of Cisco Systems, Inc.; Changing the Way We Work, Live, Play, and Learn is a service mark of Cisco Systems, Inc.; and Access Registrar, Aironet, BPX, Catalyst, CCDA, CCDP, CCIE, CCIP, CCNA, CCNP, CCSP, Cisco, the Cisco Certified Internetwork Expert logo, Cisco IOS, Cisco Press, Cisco Systems, Cisco Systems Capital, the Cisco Systems logo, Cisco Unity, Enterprise/Solver, EtherChannel, EtherFast, EtherSwitch, Fast Step, Follow Me Browsing, FormShare, GigaDrive, GigaStack, HomeLink, Internet Quotient, IOS, IP/TV, iQ Expertise, the iQ logo, iQ Net Readiness Scorecard, iQuick Study, LightStream, Linksys, MeetingPlace, MGX, Networking Academy, Network Registrar, *Packet*, PIX, ProConnect, RateMUX, ScriptShare, SlideCast, SMARTnet, StackWise, The Fastest Way to Increase Your Internet Quotient, and TransPath are registered trademarks of Cisco Systems, Inc. and/or its affiliates in the United States and certain other countries.

All other trademarks mentioned in this document or Website are the property of their respective owners. The use of the word partner does not imply a partnership relationship between Cisco and any other company. (0609R)

Any Internet Protocol (IP) addresses used in this document are not intended to be actual addresses. Any examples, command display output, and figures included in the document are shown for illustrative purposes only. Any use of actual IP addresses in illustrative content is unintentional and coincidental.

© 2006 Cisco Systems, Inc. All rights reserved.

Printed in China PRC