



# Catalyst 2955 Hardware Installation Guide

November 2004

## Corporate Headquarters

Cisco Systems, Inc.  
170 West Tasman Drive  
San Jose, CA 95134-1706  
USA  
<http://www.cisco.com>  
Tel: 408 526-4000  
800 553-NETS (6387)  
Fax: 408 526-4100

Customer Order Number: DOC-7814944=  
Text Part Number: 78-14944-03



THE SPECIFICATIONS AND INFORMATION REGARDING THE PRODUCTS IN THIS MANUAL ARE SUBJECT TO CHANGE WITHOUT NOTICE. ALL STATEMENTS, INFORMATION, AND RECOMMENDATIONS IN THIS MANUAL ARE BELIEVED TO BE ACCURATE BUT ARE PRESENTED WITHOUT WARRANTY OF ANY KIND, EXPRESS OR IMPLIED. USERS MUST TAKE FULL RESPONSIBILITY FOR THEIR APPLICATION OF ANY PRODUCTS.

THE SOFTWARE LICENSE AND LIMITED WARRANTY FOR THE ACCOMPANYING PRODUCT ARE SET FORTH IN THE INFORMATION PACKET THAT SHIPPED WITH THE PRODUCT AND ARE INCORPORATED HEREIN BY THIS REFERENCE. IF YOU ARE UNABLE TO LOCATE THE SOFTWARE LICENSE OR LIMITED WARRANTY, CONTACT YOUR CISCO REPRESENTATIVE FOR A COPY.

The following information is for FCC compliance of Class A devices: This equipment has been tested and found to comply with the limits for a Class A digital device, pursuant to part 15 of the FCC rules. These limits are designed to provide reasonable protection against harmful interference when the equipment is operated in a commercial environment. This equipment generates, uses, and can radiate radio-frequency energy and, if not installed and used in accordance with the instruction manual, may cause harmful interference to radio communications. Operation of this equipment in a residential area is likely to cause harmful interference, in which case users will be required to correct the interference at their own expense.

The following information is for FCC compliance of Class B devices: The equipment described in this manual generates and may radiate radio-frequency energy. If it is not installed in accordance with Cisco's installation instructions, it may cause interference with radio and television reception. This equipment has been tested and found to comply with the limits for a Class B digital device in accordance with the specifications in part 15 of the FCC rules. These specifications are designed to provide reasonable protection against such interference in a residential installation. However, there is no guarantee that interference will not occur in a particular installation.

Modifying the equipment without Cisco's written authorization may result in the equipment no longer complying with FCC requirements for Class A or Class B digital devices. In that event, your right to use the equipment may be limited by FCC regulations, and you may be required to correct any interference to radio or television communications at your own expense.

You can determine whether your equipment is causing interference by turning it off. If the interference stops, it was probably caused by the Cisco equipment or one of its peripheral devices. If the equipment causes interference to radio or television reception, try to correct the interference by using one or more of the following measures:

- Turn the television or radio antenna until the interference stops.
- Move the equipment to one side or the other of the television or radio.
- Move the equipment farther away from the television or radio.
- Plug the equipment into an outlet that is on a different circuit from the television or radio. (That is, make certain the equipment and the television or radio are on circuits controlled by different circuit breakers or fuses.)

Modifications to this product not authorized by Cisco Systems, Inc. could void the FCC approval and negate your authority to operate the product.

The Cisco implementation of TCP header compression is an adaptation of a program developed by the University of California, Berkeley (UCB) as part of UCB's public domain version of the UNIX operating system. All rights reserved. Copyright © 1981, Regents of the University of California.

NOTWITHSTANDING ANY OTHER WARRANTY HEREIN, ALL DOCUMENT FILES AND SOFTWARE OF THESE SUPPLIERS ARE PROVIDED "AS IS" WITH ALL FAULTS. CISCO AND THE ABOVE-NAMED SUPPLIERS DISCLAIM ALL WARRANTIES, EXPRESSED OR IMPLIED, INCLUDING, WITHOUT LIMITATION, THOSE OF MERCHANTABILITY, FITNESS FOR A PARTICULAR PURPOSE AND NONINFRINGEMENT OR ARISING FROM A COURSE OF DEALING, USAGE, OR TRADE PRACTICE.

IN NO EVENT SHALL CISCO OR ITS SUPPLIERS BE LIABLE FOR ANY INDIRECT, SPECIAL, CONSEQUENTIAL, OR INCIDENTAL DAMAGES, INCLUDING, WITHOUT LIMITATION, LOST PROFITS OR LOSS OR DAMAGE TO DATA ARISING OUT OF THE USE OR INABILITY TO USE THIS MANUAL, EVEN IF CISCO OR ITS SUPPLIERS HAVE BEEN ADVISED OF THE POSSIBILITY OF SUCH DAMAGES.

CCSP, the Cisco Square Bridge logo, Follow Me Browsing, and StackWise are trademarks of Cisco Systems, Inc.; Changing the Way We Work, Live, Play, and Learn, and iQuick Study are service marks of Cisco Systems, Inc.; and Access Registrar, Aironet, ASIST, BPX, Catalyst, CCDA, CCDP, CCIE, CCIP, CCNA, CCNP, Cisco, the Cisco Certified Internetwork Expert logo, Cisco IOS, Cisco Press, Cisco Systems, Cisco Systems Capital, the Cisco Systems logo, Cisco Unity, Empowering the Internet Generation, Enterprise/Solver, EtherChannel, EtherFast, EtherSwitch, Fast Step, FormShare, GigaDrive, GigaStack, HomeLink, Internet Quotient, IOS, IP/TV, iQ Expertise, the iQ logo, iQ Net Readiness Scorecard, LightStream, Linksys, MeetingPlace, MGX, the Networkers logo, Networking Academy, Network Registrar, *Packet*, PIX, Post-Routing, Pre-Routing, ProConnect, RateMUX, ScriptShare, SlideCast, SMARTnet, StrataView Plus, SwitchProbe, TeleRouter, The Fastest Way to Increase Your Internet Quotient, TransPath, and VCO are registered trademarks of Cisco Systems, Inc. and/or its affiliates in the United States and certain other countries.

All other trademarks mentioned in this document or Website are the property of their respective owners. The use of the word partner does not imply a partnership relationship between Cisco and any other company. (0411R)

*Catalyst 2955 Hardware Installation Guide*

Copyright © 2003-2004 Cisco Systems, Inc. All rights reserved.





**Cisco Limited 5-Year Hardware and 1-Year Software Warranty Terms** xiii

**Preface** xvii

Audience xvii

Purpose xvii

Conventions xviii

Related Publications xxvi

Obtaining Documentation xxvi

    Cisco.com xxvii

    Ordering Documentation xxvii

Documentation Feedback xxvii

Obtaining Technical Assistance xxviii

    Cisco TAC Website xxviii

    Opening a TAC Case xxix

    TAC Case Priority Definitions xxix

Obtaining Additional Publications and Information xxx

---

**CHAPTER 1**

**Configuring the Switch with the CLI-Based Setup Program** 1-1

Taking Out What You Need 1-2

Connecting to a Power Source 1-2

Connecting to the Console Port 1-4

Starting the Terminal-Emulation Software 1-5

Entering the Initial Configuration Information 1-6  
     IP Settings 1-7  
     Completing the Setup Program 1-7

**CHAPTER 2**

**Overview 2-1**

Features 2-1  
 Front-Panel Description 2-3  
     Warning Labels 2-5  
     10/100 Ports 2-6  
     10/100/1000 Ports 2-7  
     100BASE-FX Ports 2-8  
     100BASE-LX Ports 2-8  
     Power and Relay Connector 2-8  
     Console Port 2-10  
     LEDs 2-10  
         Power Status LEDs 2-12  
         10/100 Port Status LEDs 2-13  
         Uplink Port Status LEDs 2-14  
         Alarm Relay LEDs 2-16  
 Rear-Panel Description 2-17  
 Catalyst 2955 Switch Power Converter 2-17  
 Management Options 2-19

**CHAPTER 3**

**Installation 3-1**

Preparing for Installation 3-2  
     Warnings 3-2  
     EMC Regulatory Statements 3-6  
         U.S.A. 3-6  
         Class A Notice for Taiwan and Other Traditional Chinese Markets 3-6

VCCI Class A Notice for Japan	3-7
Class A Warning for Korea	3-7
Class A Warning for Hungary	3-8
Installation Guidelines	3-8
Verifying Package Contents	3-9
Applying the Switch Protective Liner	3-10
Verifying Switch Operation	3-11
Connecting a PC or a Terminal to the Console Port	3-11
Powering On the Switch and Running POST	3-13
Grounding the Switch	3-15
Wiring the DC Power Source	3-17
Add the Ferrite to the Power and Relay Connector Wiring	3-24
Attach the Power and Relay Connector to the Switch	3-25
Power On the Switch	3-27
Running POST	3-27
Connecting the Switch to the Power Converter	3-29
Installing the Power Converter on a DIN Rail	3-30
Connecting the Power Converter to the Power and Relay Connector	3-32
Connecting the Power Converter to an AC Power Source	3-35
Preparing the AC Power Cord	3-35
Connecting the AC Power Cord to the Power Converter	3-37
Connecting the Power Converter to a DC Power Source	3-41
Applying Power to the Power Converter	3-46
Removing the Power Converter from a DIN Rail	3-46
Wiring the External Alarm Device Relays	3-48
Installing the Switch on a DIN Rail	3-52
Installing the Switch in a Rack	3-57
Removing the Switch from a DIN Rail or a Rack	3-59
Connecting to 10/100 and 10/100/1000 Ports	3-62

Connecting to 100BASE-FX MM Ports 3-65  
 Connecting to 100BASE-LX SM Ports 3-67  
 Where to Go Next 3-69

**CHAPTER 4**

**Installation in a Hazardous Environment 4-1**

Preparing for Installation 4-2  
     Warnings 4-2  
     EMC Regulatory Statements 4-8  
         U.S.A. 4-8  
         Class A Notice for Taiwan and Other Traditional Chinese Markets 4-8  
         VCCI Class A Notice for Japan 4-9  
         Class A Warning for Korea 4-9  
         Class A Warning for Hungary 4-10  
     European Zone 2 Certification 4-10  
     Installation Guidelines 4-11  
     Verifying Package Contents 4-12  
 Applying the Switch Protective Liner 4-13  
 Verifying Switch Operation 4-14  
     Connecting a PC or a Terminal to the Console Port 4-14  
     Powering On the Switch and Running POST 4-16  
         Grounding the Switch 4-18  
         Wiring the DC Power Source 4-21  
         Add the Ferrite to the Power and Relay Connector Wiring 4-27  
         Attach the Power and Relay Connector to the Switch 4-28  
         Power On the Switch 4-30  
         Running POST 4-30  
 Wiring the External Alarm Device Relays 4-32  
 Installing the Switch on a DIN Rail 4-37  
 Installing the Switch in a Rack 4-42



- Removing the Switch from a DIN Rail or a Rack 4-45
- Connecting to 10/100 and 10/100/1000 Ports 4-47
- Connecting to 100BASE-FX MM Ports 4-50
- Connecting to 100BASE-LX SM Ports 4-52
- Where to Go Next 4-54

---

**CHAPTER 5****Troubleshooting 5-1**

- Understanding POST Results 5-2
- Diagnosing Problems 5-3

---

**APPENDIX A****Technical Specifications A-1**

---

**APPENDIX B****Connectors and Cables B-1**

- Connector Specifications B-1
  - 10/100 and 10/100 /1000 Ports B-2
  - 100BASE-FX Ports B-3
  - 100BASE-LX Ports B-3
  - Power and Relay Connector B-4
  - Console Port B-5
- Cable and Adapter Specifications B-5
  - Two Twisted-Pair Cable Pinouts B-6
  - Four Twisted-Pair Cable Pinouts for 10/100 Ports B-6
  - Four Twisted-Pair Cable Pinouts for 1000BASE-T Ports B-8
  - Cable and Adapter Pinouts B-9
    - Connecting to a PC B-9
    - Connecting to a Terminal B-10
    - Identifying a Crossover Cable B-11

**APPENDIX C**

**Translated Safety Warnings C-1**

- Work During Lightning Activity **C-1**
- Power and Relay Connector **C-3**
- Switch Installation In Hazardous Location **C-7**
- Safe Operating Voltage Range Warning **C-9**
- Switch Relays Warning **C-11**
- Remove Power Before Disconnecting **C-15**
- “Open Type” Equipment **C-18**
- Grounded Equipment **C-22**
- Console Cable Connection **C-24**
- Overtemperature Warning **C-27**
- Class I, Division 2, Hazardous Location **C-29**
- Twisted-pair Supply Wires **C-32**
- Pollution Degree 2 Industrial Environment **C-33**
- Port Connection **C-35**
- Installation Instructions **C-38**
- Service Personnel Warning **C-39**
- Stacking the Chassis Warning **C-41**
- Ground Connection Warning **C-42**
- SELV-IEC 60950 DC Power Supply **C-44**
- Jewelry Removal Warning **C-45**
- Product Disposal Warning **C-47**
- Class 1 Laser Product **C-49**
- Class 1 LED Product **C-50**
- Laser Radiation **C-52**
- Laser Viewing Warning **C-54**
- Laser Beam Exposure **C-56**

Chassis Warning for Rack-Mounting and Servicing	C-58
Grounded Equipment Warning	C-66
Qualified Personnel Warning	C-68
Restricted Area	C-69
Chassis Power Connection	C-72
Exposed DC Power Wire Warning	C-75

---

**INDEX**





# Cisco Limited 5-Year Hardware and 1-Year Software Warranty Terms

---

There are special terms applicable to your hardware warranty and various services that you can use during the warranty period. Your formal Warranty Statement, including the warranties and license agreements applicable to Cisco software, is available on Cisco.com. Follow these steps to access and download the *Cisco Information Packet* and your warranty and license agreements from Cisco.com.

1. Launch your browser, and go to this URL:

[http://www.cisco.com/univercd/cc/td/doc/es\\_inpk/cetrans.htm](http://www.cisco.com/univercd/cc/td/doc/es_inpk/cetrans.htm)

The Warranties and License Agreements page appears.

2. To read the *Cisco Information Packet*, follow these steps:

- a. Click the **Information Packet Number** field, and make sure that the part number 78-5235-03A0 is highlighted.
- b. Select the language in which you would like to read the document.
- c. Click **Go**.

The Cisco Limited Warranty and Software License page from the Information Packet appears.

- d. Read the document online, or click the **PDF** icon to download and print the document in Adobe Portable Document Format (PDF).



---

**Note** You must have Adobe Acrobat Reader to view and print PDF files. You can download the reader from Adobe's website: <http://www.adobe.com>

---

3. To read translated and localized warranty information about your product, follow these steps:
  - a. Enter this part number in the Warranty Document Number field:  
78-13712-01C0
  - b. Select the language in which you would like to read the document.
  - c. Click **Go**.  
The Cisco warranty page appears.
  - d. Read the document online, or click the **PDF** icon to download and print the document in Adobe Portable Document Format (PDF).

You can also contact the Cisco service and support website for assistance:

[http://www.cisco.com/public/Support\\_root.shtml](http://www.cisco.com/public/Support_root.shtml).

### **Duration of Hardware Warranty**

Five (5) Years

### **Duration of Software Warranty**

One (1) Year

### **Replacement, Repair, or Refund Policy for Hardware**

Cisco or its service center will use commercially reasonable efforts to ship a replacement part for delivery within fifteen (15) working days after receipt of the defective product at Cisco's site. Actual delivery times of replacement products can vary, depending on the customer location.

Cisco reserves the right to refund the purchase price as its exclusive warranty remedy.

### **To Receive a Return Materials Authorization (RMA) Number**

Contact the company from whom you purchased the product. If you purchased the product directly from Cisco, contact your Cisco Sales and Service Representative.

Complete the information below, and keep it for reference.

Company product purchased from	
Company telephone number	
Product model number	
Product serial number	
Maintenance contract number	







## Preface

---

### Audience

This guide is for the networking or computer technician responsible for installing a Catalyst 2955 switch, hereafter referred to as the *switch*. We assume that you are familiar with the concepts and terminology of Ethernet and local area networking.

### Purpose

This guide describes the hardware features of Catalyst 2955 switch. It describes the physical and performance characteristics of the switch, explains how to install a switch, and provides troubleshooting information.

This guide does not describe how to configure software features on your switch or describe the Catalyst 2955-specific system messages that you might encounter. It also does not provide information about command-line interface (CLI) commands that have been created or changed for use by the switch. For more information, see the software configuration, the system message, and the command reference guides for the switch.

# Conventions

This publication uses these conventions and symbols for notes, cautions, and warnings:



**Note**

Means *reader take note*. Notes contain helpful suggestions or references to materials not contained in this manual.



**Caution**

Means *reader be careful*. In this situation, you might do something that could result in equipment damage or loss of data.



**Warning**

## IMPORTANT SAFETY INSTRUCTIONS

**This warning symbol means danger. You are in a situation that could cause bodily injury. Before you work on any equipment, be aware of the hazards involved with electrical circuitry and be familiar with standard practices for preventing accidents. Use the statement number provided at the end of each warning to locate its translation in the translated safety warnings that accompanied this device.** Statement 1071

## SAVE THESE INSTRUCTIONS

**Waarschuwing**

## BELANGRIJKE VEILIGHEIDSINSTRUCTIES

**Dit waarschuwingssymbool betekent gevaar. U verkeert in een situatie die lichamelijk letsel kan veroorzaken. Voordat u aan enige apparatuur gaat werken, dient u zich bewust te zijn van de bij elektrische schakelingen betrokken risico's en dient u op de hoogte te zijn van de standaard praktijken om ongelukken te voorkomen. Gebruik het nummer van de verklaring onderaan de waarschuwing als u een vertaling van de waarschuwing die bij het apparaat wordt geleverd, wilt raadplegen.**

## BEWAAR DEZE INSTRUCTIES

**Varoitus TÄRKEITÄ TURVALLISUUSOHJEITA**

Tämä varoitusmerkki merkitsee vaaraa. Tilanne voi aiheuttaa ruumiillisia vammoja. Ennen kuin käsittelet laitteistoa, huomioi sähköpiirien käsittelemiseen liittyvät riskit ja tutustu onnettomuuksien yleisiin ehkäisytapoihin. Turvallisuusvaroitusten käännökset löytyvät laitteen mukana toimitettujen käännettyjen turvallisuusvaroitusten joukosta varoitusten lopussa näkyvien lausuntonumeroiden avulla.

**SÄILYTÄ NÄMÄ OHJEET****Attention IMPORTANTES INFORMATIONS DE SÉCURITÉ**

Ce symbole d'avertissement indique un danger. Vous vous trouvez dans une situation pouvant entraîner des blessures ou des dommages corporels. Avant de travailler sur un équipement, soyez conscient des dangers liés aux circuits électriques et familiarisez-vous avec les procédures couramment utilisées pour éviter les accidents. Pour prendre connaissance des traductions des avertissements figurant dans les consignes de sécurité traduites qui accompagnent cet appareil, référez-vous au numéro de l'instruction situé à la fin de chaque avertissement.

**CONSERVEZ CES INFORMATIONS****Warnung WICHTIGE SICHERHEITSHINWEISE**

Dieses Warnsymbol bedeutet Gefahr. Sie befinden sich in einer Situation, die zu Verletzungen führen kann. Machen Sie sich vor der Arbeit mit Geräten mit den Gefahren elektrischer Schaltungen und den üblichen Verfahren zur Vorbeugung vor Unfällen vertraut. Suchen Sie mit der am Ende jeder Warnung angegebenen Anweisungsnummer nach der jeweiligen Übersetzung in den übersetzten Sicherheitshinweisen, die zusammen mit diesem Gerät ausgeliefert wurden.

**BEWAHREN SIE DIESE HINWEISE GUT AUF.**

**Avvertenza      IMPORTANTI ISTRUZIONI SULLA SICUREZZA**

**Questo simbolo di avvertenza indica un pericolo. La situazione potrebbe causare infortuni alle persone. Prima di intervenire su qualsiasi apparecchiatura, occorre essere al corrente dei pericoli relativi ai circuiti elettrici e conoscere le procedure standard per la prevenzione di incidenti. Utilizzare il numero di istruzione presente alla fine di ciascuna avvertenza per individuare le traduzioni delle avvertenze riportate in questo documento.**

**CONSERVARE QUESTE ISTRUZIONI****Advarsel      VIKTIGE SIKKERHETSINSTRUKSJONER**

**Dette advarselssymbolet betyr fare. Du er i en situasjon som kan føre til skade på person. Før du begynner å arbeide med noe av utstyret, må du være oppmerksom på farene forbundet med elektriske kretser, og kjenne til standardprosedyrer for å forhindre ulykker. Bruk nummeret i slutten av hver advarsel for å finne oversettelsen i de oversatte sikkerhetsadvarslene som fulgte med denne enheten.**

**TA VARE PÅ DISSE INSTRUKSJONENE****Aviso      INSTRUÇÕES IMPORTANTES DE SEGURANÇA**

**Este símbolo de aviso significa perigo. Você está em uma situação que poderá ser causadora de lesões corporais. Antes de iniciar a utilização de qualquer equipamento, tenha conhecimento dos perigos envolvidos no manuseio de circuitos elétricos e familiarize-se com as práticas habituais de prevenção de acidentes. Utilize o número da instrução fornecido ao final de cada aviso para localizar sua tradução nos avisos de segurança traduzidos que acompanham este dispositivo.**

**GUARDE ESTAS INSTRUÇÕES**

**¡Advertencia! INSTRUCCIONES IMPORTANTES DE SEGURIDAD**

Este símbolo de aviso indica peligro. Existe riesgo para su integridad física. Antes de manipular cualquier equipo, considere los riesgos de la corriente eléctrica y familiarícese con los procedimientos estándar de prevención de accidentes. Al final de cada advertencia encontrará el número que le ayudará a encontrar el texto traducido en el apartado de traducciones que acompaña a este dispositivo.

**GUARDE ESTAS INSTRUCCIONES****Varning! VIKTIGA SÄKERHETSANVISNINGAR**

Denna varningssignal signalerar fara. Du befinner dig i en situation som kan leda till personskada. Innan du utför arbete på någon utrustning måste du vara medveten om farorna med elkretsar och känna till vanliga förfaranden för att förebygga olyckor. Använd det nummer som finns i slutet av varje varning för att hitta dess översättning i de översatta säkerhetsvarningar som medföljer denna anordning.

**SPARA DESSA ANVISNINGAR****Figyelem FONTOS BIZTONSÁGI ELOÍRÁSOK**

Ez a figyelmeztető jel veszélyre utal. Sérülésveszélyt rejtő helyzetben van. Mielőtt bármely berendezésen munkát végezte, legyen figyelemmel az elektromos áramkörök okozta kockázatokra, és ismerkedjen meg a szokásos balesetvédelmi eljárásokkal. A kiadványban szereplő figyelmeztetések fordítása a készülékhez mellékelt biztonsági figyelmeztetések között található; a fordítás az egyes figyelmeztetések végén látható szám alapján kereshető meg.

**ORIZZE MEG EZEKET AZ UTASÍTÁSOKAT!**

**Предупреждение**      **ВАЖНЫЕ ИНСТРУКЦИИ ПО СОБЛЮДЕНИЮ ТЕХНИКИ БЕЗОПАСНОСТИ**

Этот символ предупреждения обозначает опасность. То есть имеет место ситуация, в которой следует опасаться телесных повреждений. Перед эксплуатацией оборудования выясните, каким опасностям может подвергаться пользователь при использовании электрических цепей, и ознакомьтесь с правилами техники безопасности для предотвращения возможных несчастных случаев. Воспользуйтесь номером заявления, приведенным в конце каждого предупреждения, чтобы найти его переведенный вариант в переводе предупреждений по безопасности, прилагаемом к данному устройству.

**СОХРАНИТЕ ЭТИ ИНСТРУКЦИИ**

**警告**      重要的安全性说明

此警告符号代表危险。您正处于可能受到严重伤害的工作环境中。在您使用设备开始工作之前，必须充分意识到触电的危险，并熟练掌握防止事故发生的标准工作程序。请根据每项警告结尾提供的声明号码来找到此设备的安全性警告说明的翻译文本。

请保存这些安全性说明

**警告**      安全上の重要な注意事項

「危険」の意味です。人身事故を予防するための注意事項が記述されています。装置の取り扱い作業を行うときは、電気回路の危険性に注意し、一般的な事故防止策に留意してください。警告の各国語版は、各注意事項の番号を基に、装置に付属の「Translated Safety Warnings」を参照してください。

これらの注意事項を保管しておいてください。

## 주의      중요 안전 지침

이 경고 기호는 위험을 나타냅니다. 작업자가 신체 부상을 일으킬 수 있는 위험한 환경에 있습니다. 장비에 작업을 수행하기 전에 전기 회로와 관련된 위험을 숙지하고 표준 작업 관례를 숙지하여 사고를 방지하십시오. 각 경고의 마지막 부분에 있는 경고문 번호를 참조하여 이 장치와 함께 제공되는 번역된 안전 경고문에서 해당 번역문을 찾으십시오.

이 지시 사항을 보관하십시오.

## تحذير

### إرشادات الأمان الهامة

يوضح رمز التحذير هذا وجود خطر. وهذا يعني أنك متواجد في مكان قد ينتج عنه التعرض لإصابات. قبل بدء العمل، احذر مخاطر التعرض للصدمات الكهربائية وكن على علم بالإجراءات القياسية للحيلولة دون وقوع أي حوادث. استخدم رقم البيان الموجود في آخر كل تحذير لتحديد مكان ترجمته داخل تحذيرات الأمان المترجمة التي تأتي مع الجهاز. قم بحفظ هذه الإرشادات

## Upozorenje      VAŽNE SIGURNOSNE NAPOMENE

Ovaj simbol upozorenja predstavlja opasnost. Nalazite se u situaciji koja može prouzročiti tjelesne ozljede. Prije rada s bilo kojim uređajem, morate razumjeti opasnosti vezane uz električne sklopove, te biti upoznati sa standardnim načinima izbjegavanja nesreća. U prevedenim sigurnosnim upozorenjima, priloženima uz uređaj, možete prema broju koji se nalazi uz pojedino upozorenje pronaći i njegov prijevod.

### SAČUVAJTE OVE UPUTE

## Upozornění **DŮLEŽITÉ BEZPEČNOSTNÍ POKYNY**

Tento upozorňující symbol označuje nebezpečí. Jste v situaci, která by mohla způsobit nebezpečí úrazu. Před prací na jakémkoliv vybavení si uvědomte nebezpečí související s elektrickými obvody a seznamte se se standardními opatřeními pro předcházení úrazům. Podle čísla na konci každého upozornění vyhledejte jeho překlad v přeložených bezpečnostních upozorněních, která jsou přiložena k zařízení.

### USCHOVEJTE TYTO POKYNY

## Προειδοποίηση **ΣΗΜΑΝΤΙΚΕΣ ΟΔΗΓΙΕΣ ΑΣΦΑΛΕΙΑΣ**

Αυτό το προειδοποιητικό σύμβολο σημαίνει κίνδυνο. Βρίσκεστε σε κατάσταση που μπορεί να προκαλέσει τραυματισμό. Πριν εργαστείτε σε οποιοδήποτε εξοπλισμό, να έχετε υπόψη σας τους κινδύνους που σχετίζονται με τα ηλεκτρικά κυκλώματα και να έχετε εξοικειωθεί με τις συνήθεις πρακτικές για την αποφυγή ατυχημάτων. Χρησιμοποιήστε τον αριθμό δήλωσης που παρέχεται στο τέλος κάθε προειδοποίησης, για να εντοπίσετε τη μετάφρασή της στις μεταφρασμένες προειδοποιήσεις ασφαλείας που συνοδεύουν τη συσκευή.

### ΦΥΛΑΞΤΕ ΑΥΤΕΣ ΤΙΣ ΟΔΗΓΙΕΣ

## אזהרה

## **הוראות בטיחות חשובות**

סימן אזהרה זה מסמל סכנה. אתה נמצא במצב העלול לגרום לפציעה. לפני שתעבוד עם ציוד כלשהו, עליך להיות מודע לסכנות הכרוכות במעגלים חשמליים ולהכיר את הנהלים המקובלים למניעת תאונות. השתמש במספר ההוראה המסופק בסופה של כל אזהרה כדי לאתר את התרגום באזהרות הבטיחות המתורגמות שמצורפות להתקן.

## **שמור הוראות אלה**



**Opomena**      **ВАЖНИ БЕЗБЕДНОСНИ НАПАТСТВИЈА**  
Симболот за предупредување значи опасност. Се наоѓате во ситуација што може да предизвика телесни повреди. Пред да работите со опремата, бидете свесни за ризикот што постои кај електричните кола и треба да ги познавате стандардните постапки за спречување на несреќни случаи. Искористете го бројот на изјавата што се наоѓа на крајот на секое предупредување за да го најдете неговиот период во преведените безбедносни предупредувања што се испорачани со уредот.  
**ЧУВАЈТЕ ГИ ОВИЕ НАПАТСТВИЈА**

**Ostrzeżenie**      **WAŻNE INSTRUKCJE DOTYCZĄCE BEZPIECZEŃSTWA**  
**Ten symbol ostrzeżenia oznacza niebezpieczeństwo. Zachodzi sytuacja, która może powodować obrażenia ciała. Przed przystąpieniem do prac przy urządzeniach należy zapoznać się z zagrożeniami związanymi z układami elektrycznymi oraz ze standardowymi środkami zapobiegania wypadkom. Na końcu każdego ostrzeżenia podano numer, na podstawie którego można odszukać tłumaczenie tego ostrzeżenia w dołączonym do urządzenia dokumencie z tłumaczeniami ostrzeżeń.**

**NINIEJSZE INSTRUKCJE NALEŻY ZACHOWAĆ**

**Upozornenie**      **DŮLEŽITÉ BEZPEČNOSTNÉ POKYNY**  
**Tento varovný symbol označuje nebezpečenstvo. Nachádzate sa v situácii s nebezpečenstvom úrazu. Pred prácou na akomkoľvek vybavení si uvedomte nebezpečenstvo súvisiace s elektrickými obvodmi a oboznámte sa so štandardnými opatreniami na predchádzanie úrazom. Podľa čísla na konci každého upozornenia vyhľadajte jeho preklad v preložených bezpečnostných upozorneniach, ktoré sú priložené k zariadeniu.**

**USCHOVAJTE SI TENTO NÁVOD**

## Related Publications

These documents provide complete information about the switch and are available from this URL:

<http://www.cisco.com/univercd/cc/td/doc/product/lan/cat2950/index.htm>

You can order printed copies of documents with a DOC-xxxxxx= number from the Cisco.com sites and from the telephone numbers listed in the “[Ordering Documentation](#)” section on page xxvii.

- *Release Notes for the Catalyst 2950 and 2955 Switches* (not orderable but is available on Cisco.com)



### Note

---

Switch requirements and procedures for initial configurations and software upgrades tend to change and therefore appear only in the release notes. Before installing, configuring, or upgrading the switch, see the release notes on Cisco.com for the latest information.

---

- *Catalyst 2950 and Catalyst 2955 Switch Software Configuration Guide* (order number DOC-7811380=)
- *Catalyst 2950 and Catalyst 2955 Switch Command Reference* (order number DOC-7811381=)
- *Catalyst 2950 and Catalyst 2955 Switch System Message Guide* (order number DOC-7814233=)
- *Catalyst 2950 Switch Hardware Installation Guide* (not orderable but available on Cisco.com)
- Device manager online help (available on the switch)
- *Getting Started with Cisco Network Assistant* (not orderable but available on Cisco.com)

## Obtaining Documentation

Cisco documentation and additional literature are available on Cisco.com. Cisco also provides several ways to obtain technical assistance and other technical resources. These sections explain how to obtain technical information from Cisco Systems.

## Cisco.com

You can access the most current Cisco documentation on the World Wide Web at this URL:

<http://www.cisco.com/univercd/home/home.htm>

You can access the Cisco website at this URL:

<http://www.cisco.com>

International Cisco websites can be accessed from this URL:

[http://www.cisco.com/public/countries\\_languages.shtml](http://www.cisco.com/public/countries_languages.shtml)

## Ordering Documentation

You can find instructions for ordering documentation at this URL:

[http://www.cisco.com/univercd/cc/td/doc/es\\_inpk/pdi.htm](http://www.cisco.com/univercd/cc/td/doc/es_inpk/pdi.htm)

You can order Cisco documentation in these ways:

- Registered Cisco.com users (Cisco direct customers) can order Cisco product documentation from the Ordering tool:

<http://www.cisco.com/en/US/partner/ordering/index.shtml>

- Nonregistered Cisco.com users can order documentation through a local account representative by calling Cisco Systems Corporate Headquarters (California, USA) at 408 526-7208 or, elsewhere in North America, by calling 800 553-NETS (6387).

## Documentation Feedback

You can submit e-mail comments about technical documentation to [bug-doc@cisco.com](mailto:bug-doc@cisco.com).

You can submit comments by using the response card (if present) behind the front cover of your document or by writing to the following address:

Cisco Systems  
Attn: Customer Document Ordering  
170 West Tasman Drive  
San Jose, CA 95134-9883

We appreciate your comments.

## Obtaining Technical Assistance

For all customers, partners, resellers, and distributors who hold valid Cisco service contracts, the Cisco Technical Assistance Center (TAC) provides 24-hour-a-day, award-winning technical support services, online and over the phone. Cisco.com features the Cisco TAC website as an online starting point for technical assistance. If you do not hold a valid Cisco service contract, please contact your reseller.

### Cisco TAC Website

The Cisco TAC website provides online documents and tools for troubleshooting and resolving technical issues with Cisco products and technologies. The Cisco TAC website is available 24 hours a day, 365 days a year. The Cisco TAC website is located at this URL:

<http://www.cisco.com/tac>

Accessing all the tools on the Cisco TAC website requires a Cisco.com user ID and password. If you have a valid service contract but do not have a login ID or password, register at this URL:

<http://tools.cisco.com/RPF/register/register.do>

## Opening a TAC Case

Using the online TAC Case Open Tool is the fastest way to open P3 and P4 cases. (P3 and P4 cases are those in which your network is minimally impaired or for which you require product information.) After you describe your situation, the TAC Case Open Tool automatically recommends resources for an immediate solution. If your issue is not resolved using the recommended resources, your case will be assigned to a Cisco TAC engineer. The online TAC Case Open Tool is located at this URL:

<http://www.cisco.com/tac/caseopen>

For P1 or P2 cases (P1 and P2 cases are those in which your production network is down or severely degraded) or if you do not have Internet access, contact Cisco TAC by telephone. Cisco TAC engineers are assigned immediately to P1 and P2 cases to help keep your business operations running smoothly.

To open a case by telephone, use one of the following numbers:

Asia-Pacific: +61 2 8446 7411 (Australia: 1 800 805 227)

EMEA: +32 2 704 55 55

USA: 1 800 553-2447

For a complete listing of Cisco TAC contacts, go to this URL:

<http://www.cisco.com/warp/public/687/Directory/DirTAC.shtml>

## TAC Case Priority Definitions

To ensure that all cases are reported in a standard format, Cisco has established case priority definitions.

**Priority 1 (P1)**—Your network is “down” or there is a critical impact to your business operations. You and Cisco will commit all necessary resources around the clock to resolve the situation.

**Priority 2 (P2)**—Operation of an existing network is severely degraded, or significant aspects of your business operation are negatively affected by inadequate performance of Cisco products. You and Cisco will commit full-time resources during normal business hours to resolve the situation.

Priority 3 (P3)—Operational performance of your network is impaired, but most business operations remain functional. You and Cisco will commit resources during normal business hours to restore service to satisfactory levels.

Priority 4 (P4)—You require information or assistance with Cisco product capabilities, installation, or configuration. There is little or no effect on your business operations.

## Obtaining Additional Publications and Information

Information about Cisco products, technologies, and network solutions is available from various online and printed sources.

- Cisco Marketplace provides a variety of Cisco books, reference guides, and logo merchandise. Go to this URL to visit the company store:

<http://www.cisco.com/go/marketplace/>

- The Cisco *Product Catalog* describes the networking products offered by Cisco Systems, as well as ordering and customer support services. Access the Cisco Product Catalog at this URL:

<http://cisco.com/univercd/cc/td/doc/pcat/>

- *Cisco Press* publishes a wide range of general networking, training and certification titles. Both new and experienced users will benefit from these publications. For current Cisco Press titles and other information, go to Cisco Press online at this URL:

<http://www.ciscopress.com>

- *Packet* magazine is the Cisco quarterly publication that provides the latest networking trends, technology breakthroughs, and Cisco products and solutions to help industry professionals get the most from their networking investment. Included are networking deployment and troubleshooting tips, configuration examples, customer case studies, tutorials and training, certification information, and links to numerous in-depth online resources. You can access Packet magazine at this URL:

<http://www.cisco.com/packet>

- *iQ Magazine* is the Cisco bimonthly publication that delivers the latest information about Internet business strategies for executives. You can access iQ Magazine at this URL:

<http://www.cisco.com/go/iqmagazine>

- *Internet Protocol Journal* is a quarterly journal published by Cisco Systems for engineering professionals involved in designing, developing, and operating public and private internets and intranets. You can access the Internet Protocol Journal at this URL:

<http://www.cisco.com/ipj>

- Training—Cisco offers world-class networking training. Current offerings in network training are listed at this URL:

<http://www.cisco.com/en/US/learning/index.html>







# Configuring the Switch with the CLI-Based Setup Program

---

This chapter provides a command-line interface (CLI)-based setup procedure for a standalone switch. For product overview information, see [Chapter 2, “Overview.”](#) Before connecting the switch to a power source, review the safety warnings in [Chapter 3, “Installation.”](#) For procedures on connecting the switch to a power source, rack-mounting your switch, or connecting to the Ethernet ports, see [Chapter 3, “Installation.”](#)



## Caution

---

If you are installing your switch in a hazardous environment, review the safety warnings in [Chapter 4, “Installation in a Hazardous Environment.”](#) For installation procedures for a hazardous environment, see [Chapter 4, “Installation in a Hazardous Environment.”](#)

---

These steps describe how to do a simple installation:

1. [Taking Out What You Need, page 1-2](#)
2. [Connecting to the Console Port, page 1-4](#)
3. [Starting the Terminal-Emulation Software, page 1-5](#)
4. [Connecting to a Power Source, page 1-2](#)
5. [Entering the Initial Configuration Information, page 1-6](#)

# Taking Out What You Need

Remove the items shown in [Figure 1-1](#) from the shipping container:

**Figure 1-1** Catalyst 2955 Switch and Adapter Cable

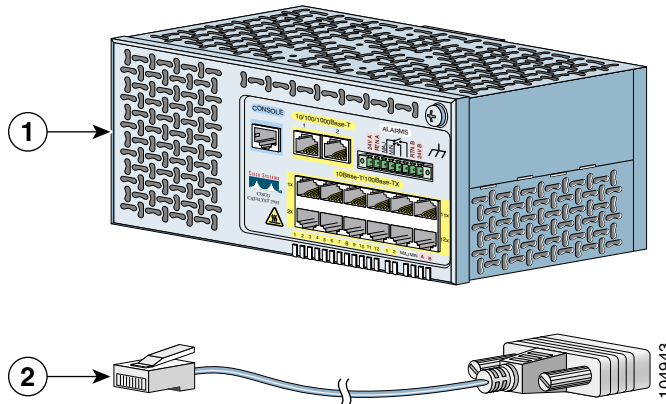

<b>1</b>	Catalyst 2955 switch	<b>2</b>	RJ-45-to-DB-9 adapter cable
----------	----------------------	----------	-----------------------------



**Note**

You need to provide the Category 5 straight-through cables to connect the switch ports to other Ethernet devices.

## Connecting to a Power Source

For instructions on connecting the Catalyst 2955 switch to direct current (DC) power, see the [“Wiring the DC Power Source”](#) section on page 3-17. For instructions on connecting the Catalyst 2955 switch to alternating current (AC) or DC power by using the optional power converter, see the [“Connecting the Switch to the Power Converter”](#) section on page 3-29.

After the power is applied, the switch automatically begins POST, a series of tests that verifies that the switch functions properly.

**Note**

---

The uplink port status LEDs provide system and status information during POST. On the Catalyst 2955C-12 and 2955S-12, the uplink ports are labeled 13 and 14. On the Catalyst 2955T-12, the uplink ports are labeled 1 and 2.

---

When the Catalyst 2955C-12 and 2955S-12 begin POST:

- Uplink port 13 LED is amber.
- Uplink port 14 LED blinks green.

When the Catalyst 2955T-12 begins POST:

- Uplink port 1 LED is amber.
- Uplink port 2 LED blinks green.

If POST completes successfully on the Catalyst 2955C-12 and 2955S-12:

- Uplink port 13 LED turns green.
- Uplink port 14 LED goes off during the flash file system initialization.

If POST completes successfully on the Catalyst 2955T-12:

- Uplink port 1 LED turns green.
- Uplink port 2 LED goes off during the flash file system initialization.

If POST fails on the Catalyst 2955C-12 and 2955S-12:

- Uplink port 13 LED blinks amber.
- Uplink port 14 LED turns green.

If POST fails on the Catalyst 2955T-12:

- Uplink port 1 LED blinks amber.
- Uplink port 2 LED turns green.

**Note**

---

POST failures are usually fatal. Call Cisco Systems immediately if your switch does not pass POST. See the [“Obtaining Technical Assistance”](#) section on page xxviii.

---

# Connecting to the Console Port

You can use the console port to perform the initial configuration. To connect the switch console port to a PC, use the supplied RJ-45-to-DB-9 adapter cable.



## Warning

---

**Do not connect or disconnect cables to the ports while power is applied to the switch or any device on the network because an electrical arc can occur. This could cause an explosion in hazardous location installations. Be sure that power is removed from the switch and cannot be accidentally be turned on, or verify that the area is nonhazardous before proceeding.** Statement 1070

---

Follow these steps to connect the PC or terminal to the switch:

- 
- Step 1** Using the supplied RJ-45-to-DB-9 adapter cable, insert the RJ-45 connector into the console port on the rear of a switch, as shown in [Figure 1-2](#).
- Step 2** Attach the DB-9 female DTE of the adapter cable to a PC serial port, or attach an appropriate adapter to the terminal.
-

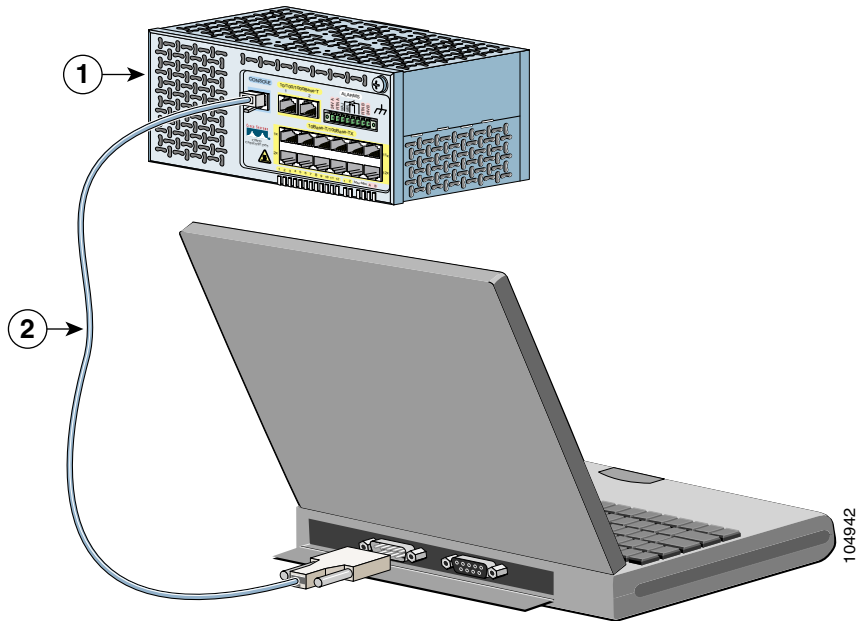
**Figure 1-2** Connecting a Switch to a PC

1	Catalyst 2955 switch	2	RJ-45-to-DB-9 adapter cable
---	----------------------	---	-----------------------------

## Starting the Terminal-Emulation Software

Before you power on the switch, start the terminal-emulation session on your PC so that you can see the output display from the power-on self-test (POST).

**Warning**

---

**If you connect or disconnect the console cable with power applied to the switch or any device on the network, an electrical arc can occur. This could cause an explosion in hazardous location installations. Be sure that power is removed or the area is nonhazardous before proceeding.**

**To verify switch operation, perform POST on the switch in a nonhazardous location before installation.** Statement 1065

---

The terminal-emulation software—frequently a PC application such as Hyperterminal or ProcommPlus—makes communication between the switch and your PC or terminal possible.

Follow these steps to start a terminal-emulation session:

- 
- Step 1** Start the terminal-emulation program if you are using a PC or terminal.
- Step 2** Configure the baud rate and data format of the PC or terminal to match these console port default characteristics:
- 9600 baud
  - 8 data bits
  - 1 stop bit
  - No parity
  - None (flow control)
- 

## Entering the Initial Configuration Information

To set up the switch, you need to complete the setup program, which runs automatically after the switch is powered on. You must assign an IP address and other configuration information necessary for the switch to communicate with the local routers and the Internet. This information is also required if you plan to use the Network Assistant to configure and manage the switch.

## IP Settings

You will need this information from your network administrator before you complete the setup program:

- Switch IP address
- Subnet mask (IP netmask)
- Default gateway (router)
- Enable secret password
- Enable password
- Telnet password

## Completing the Setup Program

Follow these steps to complete the setup program and to create an initial configuration for the switch:

---

**Step 1** Enter **Yes** at these two prompts.

```
Would you like to enter the initial configuration dialog? [yes/no]:  
yes
```

At any point you may enter a question mark '?' for help.  
Use `ctrl-c` to abort configuration dialog at any prompt.  
Default settings are in square brackets '[]'.

Basic management setup configures only enough connectivity  
for management of the system, extended setup will ask you  
to configure each interface on the system.

```
Would you like to enter basic management setup? [yes/no]: yes
```

**Step 2** Enter a host name for the switch, and press **Return**.

On a command switch, the host name is limited to 28 characters; on a member switch to 31 characters. Do not use `-n`, where `n` is a number, as the last character in a host name for any switch.

```
Enter host name [Switch]: host_name
```

**Step 3** Enter an enable secret password, and press **Return**.

The password can be from 1 to 25 alphanumeric characters, can start with a number, is case sensitive, allows spaces, but ignores leading spaces. The secret password is encrypted, and the enable password is in plain text.

```
Enter enable secret: secret_password
```

**Step 4** Enter an enable password, and press **Return**.

```
Enter enable password: enable_password
```



---

**Note** The CLI issues a warning message if the enable secret and enable passwords are the same.

You can override this warning by re-entering the password or by choosing a different password for the enable secret password.

---

**Step 5** Enter a virtual terminal (Telnet) password, and press **Return**.

The password can be from 1 to 25 alphanumeric characters, is case sensitive, allows spaces, but ignores leading spaces.

```
Enter virtual terminal password: terminal-password
```

**Step 6** (Optional) Configure Simple Network Management Protocol (SNMP) by responding to the prompts. You can also configure SNMP later through the CLI, the device manager, or the Network Assistant application. To configure SNMP later, enter **no**.

```
Configure SNMP Network Management? [no]: no
```



---

**Note** For instructions on how to configure SNMP, see the switch software configuration guide.

---

**Step 7** Enter the interface name (physical interface or virtual local-area network [VLAN] name) of the interface that connects to the management network, and press **Return**. For this release, always use `vlan1` as that interface.

```
Enter interface name used to connect to the
management network from the above interface summary: vlan1
```



- Step 8** Configure the interface by entering the switch IP address and subnet mask and pressing **Return**. The IP address and subnet masks shown below are examples.

```
Configuring interface vlan1:
Configure IP on this interface? [yes]: yes
IP address for this interface: 10.4.120.106
Subnet mask for this interface [255.0.0.0]: 255.0.0.0
```

- Step 9** Enter **Y** to configure the switch as the cluster command switch. Enter **N** to configure it as a member switch or as a standalone switch.

If you enter **N**, the switch appears as a candidate switch in the Network Assistant GUI. You can configure the switch as a command switch later through the CLI, the device manager, or the Network Assistant application. To configure it later, enter **no**.

```
Would you like to enable as a cluster command switch? [yes/no]: no
```

You have now completed the initial configuration of the switch, and the switch displays that configuration. This is an example of the output that appears:

The following configuration command script was created:

```
hostname host_name
enable secret 5 $1$Max7$Qgr9eXBhtcBJw3KK7bc850
enable password my
line vty 0 15
password my_password
snmp-server community public
!
no ip routing
!
interface Vlan1
no shutdown
ip address 172.20.139.145 255.255.255.224
!
interface Vlan2
shutdown
no ip address
!
interface FastEthernet0/1
!
interface FastEthernet0/2
!
...<output abbreviated>
!!!
interface GigabitEthernet0/1
!
interface GigabitEthernet0/2
```

```
!  
end
```

**Step 10** These choices appear:

```
[0] Go to the IOS command prompt without saving this config.  
[1] Return back to the setup without saving this config.  
[2] Save this configuration to nvram and exit.
```

If you want to save the configuration and use it the next time the switch reboots, save it in nonvolatile RAM (NVRAM) by selecting option 2.

```
Enter your selection [2]:2
```

Make your selection, and press **Return**.

---

After you complete the setup program, the switch can run the default configuration that you created. If you want to change this configuration or want to perform other management tasks, use one of these tools:

- Command-line interface (CLI)
- Network Assistant (for one or more switches)

To use the CLI, enter commands at the *Switch>* prompt through the console port by using a terminal-emulation program or through the network by using Telnet. For configuration information, see the switch software configuration guide or the switch command reference.

To use the Network Assistant, see the *Getting Started with Cisco Network Assistant* guide on Cisco.com.



## Overview

---

This chapter provides these topics that describe the Catalyst 2955 switch, hereafter referred to as *the switch*.

- [Features, page 2-1](#)
- [Front-Panel Description, page 2-3](#)
- [Rear-Panel Description, page 2-17](#)
- [Catalyst 2955 Switch Power Converter, page 2-17](#)

## Features

The Catalyst 2955 switch is a member of the Catalyst 2950 switch family. Catalyst switches are a series of Ethernet switches that you can use to connect any Ethernet-enabled devices.

The Catalyst 2955 switch is an Ethernet switch that mounts on a DIN rail in an industrial enclosure as well as in a standard 19-inch rack. Its components are designed to withstand extremes in temperature, vibration, and shock so that the switch can be deployed in an industrial environment.



---

**Note**

The Catalyst 2955 switch does not have cooling fans

---

See the switch software configuration guide for examples that show how you might deploy the switches in your network.

Figure 2-1 through Figure 2-3 show the Catalyst 2955 switches.

These are the switch features:

- Hardware
  - Catalyst 2955T-12 switch—12 10/100 ports and 2 10/100/1000BASE-T ports
  - Catalyst 2955C-12 switch—12 10/100 ports and 2 multimode (MM) 100BASE-FX ports
  - Catalyst 2955S-12 switch—12 10/100 ports and 2 single-mode (SM) 100BASE-LX ports
- Configuration
  - For 10/100BASE-TX ports, autonegotiates the speed and duplex settings
  - For 10/100/1000 BASE-T uplink ports, autonegotiates the speed and supports half- and full-duplex operation at 10/100 Mbps and full-duplex operation at 1000 Mbps
  - For 100BASE-FX multimode fiber-optic MM uplink ports, supports only 100-Mbps and full-duplex settings
  - For 100BASE-LX single-mode fiber-optic SM uplink ports, supports only 100-Mbps and full-duplex settings

# Front-Panel Description

The switch front panel contains the ports, the LEDs, and the power and relay cable connector.

Figure 2-1 to Figure 2-3 show the switch front panels.

**Figure 2-1 Catalyst 2955T-12 Switch**

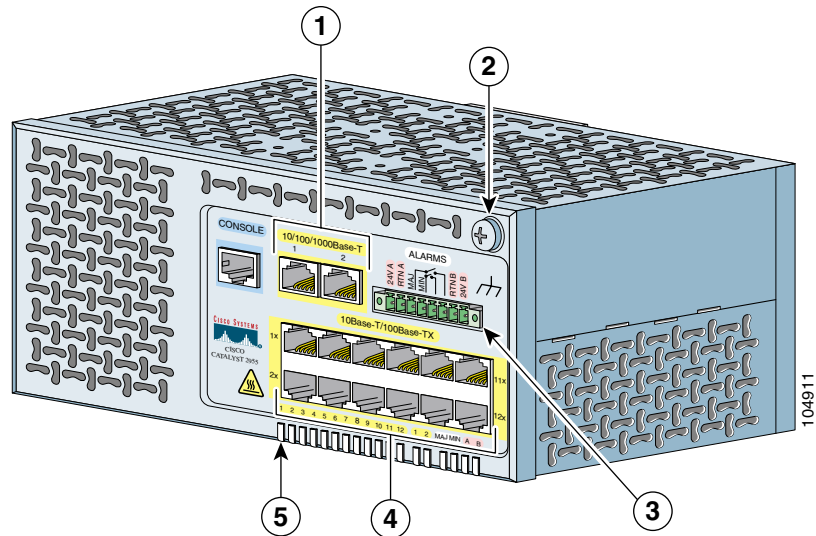

<b>1</b>	10/100/1000 uplink ports	<b>4</b>	10/100 ports
<b>2</b>	Functional ground screw	<b>5</b>	LEDs
<b>3</b>	Power and relay connector		

Figure 2-2 Catalyst 2955C-12 Switch

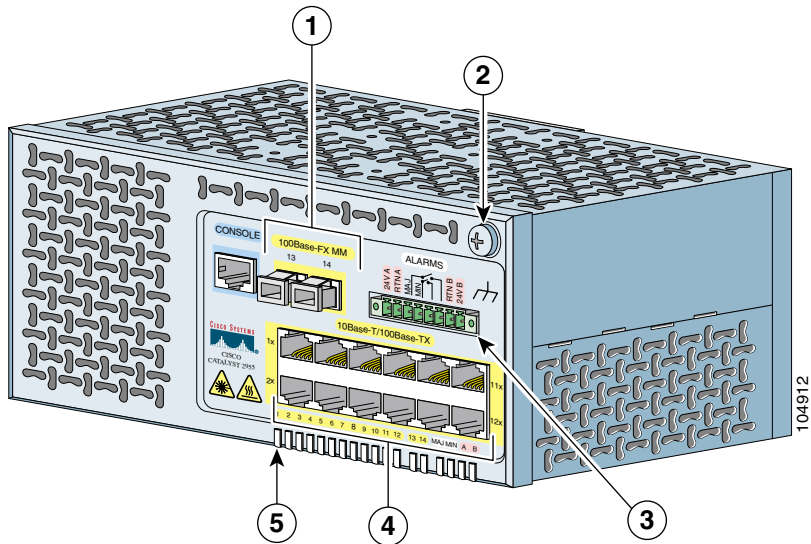

<b>1</b>	100BASE-FX uplink ports	<b>4</b>	10/100 ports
<b>2</b>	Functional ground screw	<b>5</b>	LEDs
<b>3</b>	Power and relay connector		

Figure 2-3 Catalyst 2955S-12 Switch

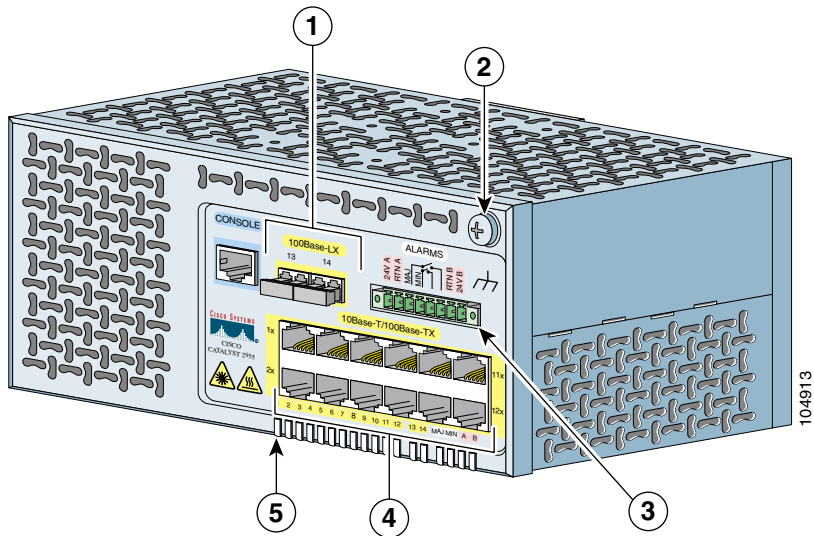

1	100BASE-LX uplink ports	4	10/100 ports
2	Functional ground lug	5	LEDs
3	Power and relay connector		

## Warning Labels

The laser safety warning label (as shown in [Figure 2-4](#)) is on the Catalyst 2955C-12 and 2955S-12 switch front panels. The MM fiber-optic ports on the Catalyst 2955C-12 are Class 1 LEDs. The SM fiber-optic uplink ports on the Catalyst 2955S-12 are Class 1 laser products.

The laser safety warning label means that you should be careful when working with fiber-optic ports and cabling. See [Appendix C, “Translated Safety Warnings”](#) for more information about laser safety guidelines.

**Figure 2-4 Laser Safety Warning Label**

The hot surface warning label (shown in [Figure 2-5](#)) is on the Catalyst 2955C-12, 2955S-12, and 2955T-12 switch front panels. This label means that the surface of the switch is hot. See [Appendix C, “Translated Safety Warnings,”](#) for more information about proper handling guidelines for hot surfaces.

**Figure 2-5 Hot Surface Warning Label**

## 10/100 Ports

The 10/100 ports use RJ-45 connectors and twisted-pair cabling. The ports can connect to these devices:

- 10BASE-T devices, such as workstations and hubs, through standard RJ-45 connectors and two twisted-pair cabling. You can use Category 3, 4, or 5 cabling.
- 100BASE-TX devices, such as high-speed workstations, servers, hubs, routers, and other switches, through standard RJ-45 connectors and two or four twisted-pair, Category 5 cabling.

**Note**

---

When connecting the switch to workstations, servers, and routers, be sure that the cable is a twisted-pair straight-through cable. When connecting the switch to hubs or other switches, use a twisted-pair crossover cable. Pinouts for the cables are described in [Appendix B, “Connectors and Cables.”](#)

---

The 10/100 ports can be set to operate in any combination of half duplex, full duplex, 10 Mbps, or 100 Mbps. They can also be set for speed and duplex autonegotiation, compliant with IEEE 802.3U. In all cases, the cable length from a switch to an attached device cannot exceed 328 feet (100 meters).



When set for autonegotiation, a port senses the speed and duplex settings of the attached device and advertises its own capabilities. If the attached device supports autonegotiation, the port negotiates the best connection (that is, the fastest line speed that both devices support and full-duplex transmission, if the attached device supports it) and configures itself accordingly.

## 10/100/1000 Ports

The 10/100/1000 uplink ports on the Catalyst 2955T-12 switch use RJ-45 connectors and twisted-pair cabling. The ports can connect to these devices:

- 10BASE-T devices, such as workstations and hubs, through standard RJ-45 connectors and two or four twisted-pair, Category 3, 4, or 5 cabling.
- 100BASE-TX devices, such as high-speed workstations, servers, hubs, routers, and other switches, through standard RJ-45 connectors and two or four twisted-pair, Category 5 cabling.
- 1000BASE-T devices, such as high-speed workstations, servers, hubs, routers, and other switches, through standard RJ-45 connectors and four twisted-pair, Category 5 cabling.



---

**Note**

When connecting the switch to a 1000BASE-T device, be sure to use a four twisted-pair, Category 5 cable.

---



---

**Note**

When connecting the switch to workstations, servers, and routers, be sure to use a twisted-pair straight-through cable. When connecting the switch to hubs or other switches, use a twisted-pair crossover cable. Pinouts for the cables are described in [Appendix B, “Connectors and Cables.”](#)

---

The 10/100/1000 ports on the Catalyst 2955T-12 switch can be set to operate at 10 or 100 Mbps at half- or full-duplex mode or 1000 Mbps in full-duplex mode. They can also be set for speed autonegotiation, compliant with IEEE 802.3ab. In all cases, the cable length from a switch to an attached device cannot exceed 328 feet (100 meters).

## 100BASE-FX Ports

The 100BASE-FX ports on the Catalyst 2955C-12 use 50/125- or 62.5/125-micron MM fiber-optic cabling. In full-duplex mode, the MM fiber-optic cable length from a switch to an attached device cannot exceed 6562 feet (2 kilometers).

For MM connections, you can connect a 100BASE-FX port to a port on a target device by using one of the MT-RJ fiber-optic patch cables listed in [Table B-1 on page B-3](#). Use the Cisco part numbers in [Table B-1](#) to order the patch cables that you need.

## 100BASE-LX Ports

The 100BASE-LX ports on the Catalyst 2955S-12 use 9/125-micron SM fiber-optic cabling. The cable length from a switch to an attached device cannot exceed 9.375 miles (15 kilometers).

For SM connections, use one of the connectors listed in [Table B-2 on page B-4](#). Use the Cisco part numbers in [Table B-2](#) to order the connectors that you need.

## Power and Relay Connector

The power and relay connector provides wire connections to the switch for DC power and configurable alarms (see [Figure 2-6](#)). The power and relay connector is to the right of the uplink ports on the faceplate.

**Figure 2-6** Power and Relay Connector

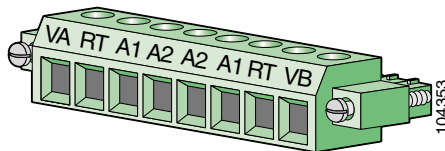

The connector is a pluggable-screw terminal block connector that provides power and return connections for both the primary and secondary power supplies. The positive DC power connection for power supply A is labeled VA, and the return for power supply A is the adjacent connection labeled RT. For power supply B (the redundant power supply), the positive DC power connection is labeled VB, and the return is the adjacent connection labeled RT.

The Catalyst 2955 switch can operate with a single power supply or with dual power supplies. In dual-power mode, the switch draws power from the power supply with higher voltage. If the primary power supply fails in dual-power mode, the alternate power supply gives power to the switch.

**Warning**

---

**When you connect or disconnect the power and relay connector with power applied, an electrical arc can occur. This could cause an explosion in hazardous area installations. Be sure that power is removed from the switch and alarm circuit. Be sure that power cannot be accidentally turned on or verify that the area is nonhazardous before proceeding.**

**Failure to securely tighten the power and relay connector captive screws can result in an electrical arc if the connector is accidentally removed.** Statement 1058

---

The power and relay connector provides an interface for two independent, normally open (NO) alarm relays. The relays can be triggered by alarms for environmental, power supply, and port status conditions. The relays can be configured to send a fault signal to an external alarm device, such as a bell or a light indicator. You can use the CLI to associate any alarm condition with a single alarm relay or with both relays.

To connect an external alarm device to the relay, you must connect two relay contact wires to complete an electrical circuit. Because each external alarm device requires two connections to a relay, the Catalyst 2955 switch supports a maximum of two external alarm devices.

**Note**

---

See the switch configuration guide for instructions on how to configure the alarm relays.

---

For more information about the power and relay connector, see [Appendix B, “Connectors and Cables.”](#)

**Note**

---

You can get replacement power and relay connectors (PWR-2955-CONNECT=) by calling Cisco Technical Support. See the [“Obtaining Technical Assistance” section on page xxviii](#).

---

## Console Port

You can connect a switch to a PC through the console port and the supplied RJ-45-to-DB-9 adapter cable. If you want to connect a switch to a terminal, you need to provide an RJ-45-to-DB-25 female DTE adapter. You can order a kit (part number ACS-DSBUASYN=) with that adapter from Cisco Systems. For console-port and adapter-pinout information, see the [“Cable and Adapter Specifications” section on page B-5](#).

**Warning**

---

**If you connect or disconnect the console cable with power applied to the switch or any device on the network, an electrical arc can occur. This could cause an explosion in hazardous location installations. Be sure that power is removed or the area is nonhazardous before proceeding.**

**To verify switch operation, perform POST on the switch in a nonhazardous location before installation.**Statement 1065

---

## LEDs

You can use the LEDs to monitor switch activity and performance. The LEDs on all Catalyst 2955 switches are on the bottom edge of the front panel. The LEDs are visible in both face-up and parallel mounting configurations, as shown in [Figure 2-7](#) and [Figure 2-8](#).

**Note**

---

The 10/100 port status LEDs show port status only.

---

All LEDs are visible through the GUI management applications—the Network Assistant application for multiple switches and the device manager GUI for a single switch. The switch software configuration guide describes how to use the CLI to configure and to monitor individual switches and switch clusters.

Figure 2-7 LEDs on the Catalyst 2955T-12 Switch

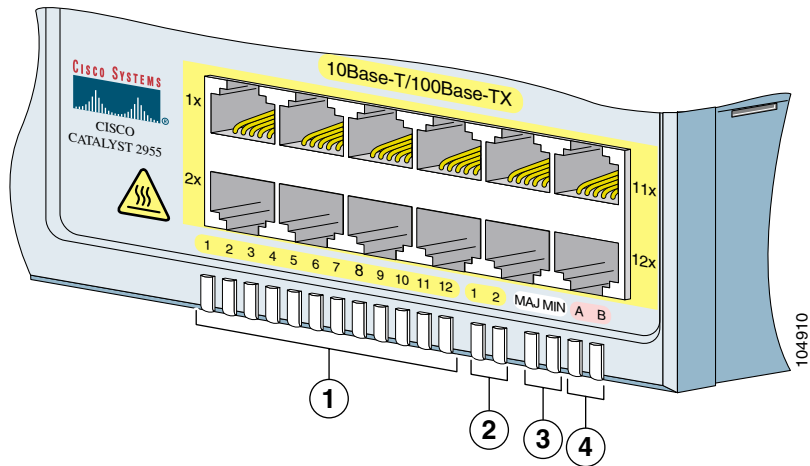

<b>1</b>	10/100 port status LEDs	<b>3</b>	Alarm relay LEDs
<b>2</b>	Uplink port status LEDs	<b>4</b>	Power supply LEDs

**Figure 2-8 LEDs on Catalyst 2955C-12 and Catalyst 2955S-12 Switches**

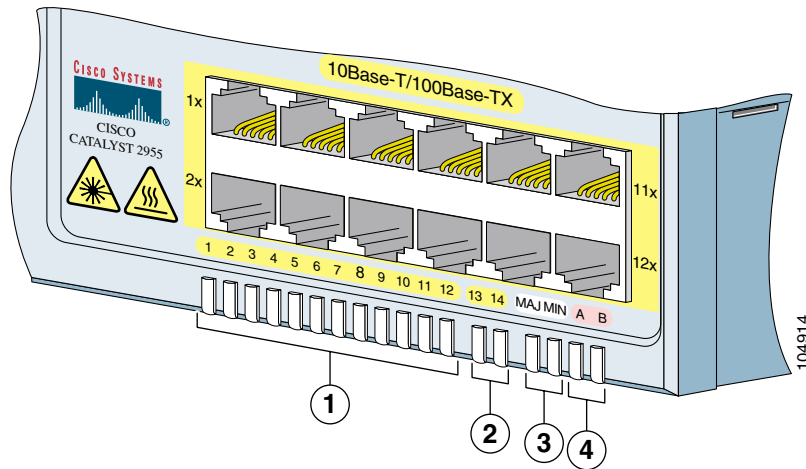

<b>1</b>	10/100 port status LEDs	<b>3</b>	Alarm relay LEDs
<b>2</b>	Uplink port status LEDs	<b>4</b>	Power supply LEDs

## Power Status LEDs

The Catalyst 2955 switch can operate with one or two power supplies. Each power supply input has an associated LED that shows the power supply status.

If the switch is in single-power mode and only power supply A is present and functioning, the LED for power supply B is green, and the LED for power supply A shows its status.

If the switch is in single-power mode and only power supply B is present and functioning, the LED for power supply A is green, and the LED for power supply B shows its status.

In dual-power mode, the switch draws power from the power supply with the higher voltage. If the primary power supply fails in dual-power mode, the alternate power supply gives power to the switch.

The power status LEDs show whether the individual power supplies are receiving power and functioning properly.

[Table 2-1](#) lists the LED colors and meanings.

**Note**

The power status LEDs show that power is not present on the switch if the power input drops below 17 V. The power status LEDs only show that power is present if the voltage at the switch input exceeds 18.5 V. The 1.5 V difference, or *hysteresis*, ensures that the power status LEDs do not oscillate at values near 18 V.

In dual-power mode, the power status LEDs show status for both power inputs, VA and VB.

**Table 2-1 Power Status LEDs**

Color	System Status
Off	System is not powered up.
Green	Power present on associated contact.
Red	Power not present on associated contact.

For information about the power LED colors during the power-on self-test (POST), see the [“Powering On the Switch and Running POST”](#) section on page 3-13.

## 10/100 Port Status LEDs

Each 10/100 port has a port status LED, also called a port LED, shown in [Figure 2-7](#) and [Figure 2-8](#). These LEDs display information about the switch and the individual ports, shown in [Table 2-2](#).

**Table 2-2 10/100 Port Status LEDs**

Color	System Status
Off	No link.
Solid green	Link present.
Flashing green	Activity. Port is transmitting or receiving data.
Alternating green-amber	Link fault. Error frames can affect connectivity, and errors such as excessive collisions, CRC errors, and alignment and jabber errors are monitored for a link-fault indication.
Solid amber	Port is not forwarding. Port was disabled by management, an address violation, or Spanning Tree Protocol (STP).  <b>Note</b> After a port is reconfigured, the port LED can remain amber for up to 30 seconds while STP checks the switch for possible loops.

## Uplink Port Status LEDs

The Catalyst 2955 switch has two uplink port status LEDs to the right of the port status LEDs. On the Catalyst 2955C-12 and 2955S-12 switches, the fiber-optic uplink port status LEDs are labeled 13 and 14 (see [Figure 2-8](#)). On the Catalyst 2955T-12, the 10/100/1000BASE-T uplink ports are labeled 1 and 2 (see [Figure 2-7](#)).

These LEDs display information about the switch and the individual uplink ports, as shown in [Table 2-3](#), [Table 2-4](#), and [Table 2-5](#).



### Note

The uplink port status LEDs provide system and status information during POST. See the “[Powering On the Switch and Running POST](#)” section on page 3-13 for more information about uplink port LED colors during POST.

**Table 2-3 10/100/1000BASE-T Uplink Port Status LEDs**

Color	System Status
Off	No link.
Solid green	Link is present.



**Table 2-3 10/100/1000BASE-T Uplink Port Status LEDs (continued)**

<b>Color</b>	<b>System Status</b>
Flashing green	Activity. Port is transmitting or receiving data.
Alternating green-amber	Link is faulty.
Solid amber	Link is disabled.

**Table 2-4 100BASE-FX MM Uplink Port Status LEDs**

<b>Color</b>	<b>System Status</b>
Off	No link.
Solid green	Link is present.
Flashing green	Activity. Port is transmitting or receiving data.
Alternating green-amber	Link is faulty.
Solid amber	Link is disabled.

**Table 2-5 100BASE-LX SM Uplink Port Status LEDs**

<b>Color</b>	<b>System Status</b>
Off	No link.
Solid green	Link is present.
Flashing green	Activity. Port is transmitting or receiving data.
Alternating green-amber	Link is faulty.
Solid amber	Link is disabled.

## Alarm Relay LEDs

Two alarm relay LEDs labeled MAJ and MIN are to the right of the uplink port status LEDs, as shown in [Figure 2-7](#) and [Figure 2-8](#). These LEDs reflect the state of the major and minor system alarms.

You can use the Cisco IOS command-line interface (CLI) to configure the major and minor LEDs to drive the relay contacts so that the connected external alarm device state mirrors the alarm state of the major (MAJ) or minor (MIN) LED. You can also use the CLI to associate port and global status alarms to one or both relays. See the switch software configuration guide for details.



### Warning

**The switch relays are rated at 1 Amp and have a voltage limit of 30 VDC and 0.3 Amp at a voltage limit of 125 VAC. It is dangerous to exceed these limitations in a hazardous environment.**

**An electrical arc can occur when you connect or disconnect the relay wires with field side power applied. This could cause an explosion in switch installations in a hazardous location. Before proceeding, be sure that power is removed or the area is not hazardous.** Statement 1061.

[Table 2-6](#) lists the LED colors and meanings.

**Table 2-6 Alarm and Relay LEDs**

LED	Color	Meaning
Major relay (MAJ)	Off	Environmental temperature is within normal range, or connected alarm is not in a state of fault.
	Red	Environmental temperature exceeds maximum threshold, or connected alarm is in a state of fault.
Minor relay (MIN)	Off	Connected alarm is not in a state of fault.
	Red	Connected alarm is in a state of fault.



### Note

The minor LED is disabled by default.

# Rear-Panel Description

The rear panel of the Catalyst 2955 switch has a DIN rail mounting clip assembly, as shown in [Figure 2-9](#).

The switch ships with the clip assembly installed on the rear panel, for a parallel mounting configuration.

**Figure 2-9 Catalyst 2955 Switch Rear Panel**

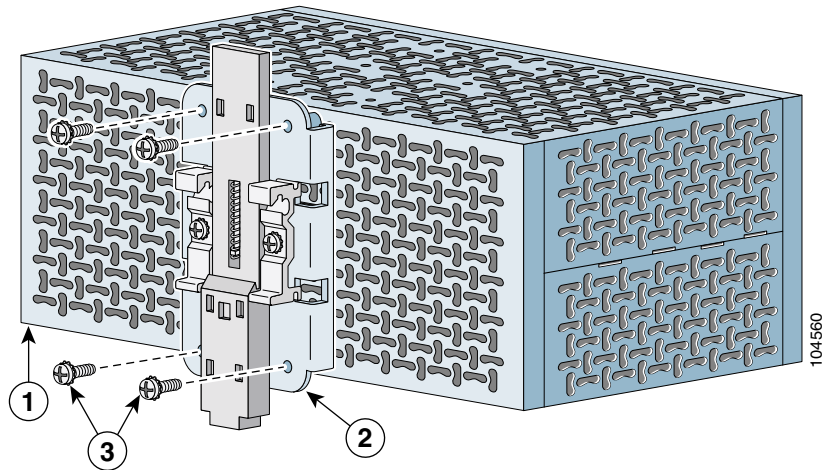

<b>1</b>	Catalyst 2955 switch rear panel	<b>3</b>	DIN rail clip mounting screws
<b>2</b>	DIN rail clip assembly		

## Catalyst 2955 Switch Power Converter

The Catalyst 2955 switch can be used with an optional AC/DC power converter in a nonhazardous environment. The power converter (PWR-2955-AC=) can supply 24 VDC power in three modes—110 V nominal AC, 220 V nominal AC, and up to 375 VDC (see [Table 3-2](#))—to one or two Catalyst 2955 switches. The power converter is mounted on a DIN rail.

For installation and connection procedures for the power converter, see the [“Connecting the Switch to the Power Converter”](#) section on page 3-29.

**Caution**

The power converter should only be used in a nonhazardous location installation.

**Note**

The power converter (PWR-2955-AC=) is sold separately.

Figure 10 shows the power converter.

**Figure 10** The Catalyst 2955 Switch AC/DC Power Converter

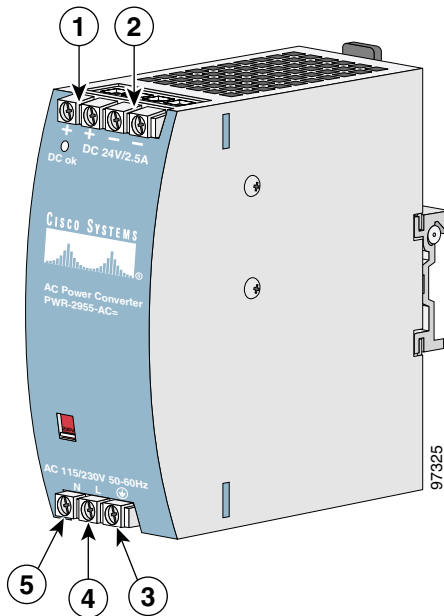

<b>1</b>	DC positive connections	<b>4</b>	AC line connection
<b>2</b>	DC return connections	<b>5</b>	AC neutral connection
<b>3</b>	Earth ground connection		

# Management Options

Catalyst 2955 switches offer these management options:

- Network Assistant

Cisco Network Assistant is a PC-based network management GUI application optimized for LANs of small and medium-sized businesses. Cisco Network Assistant offers centralized management of Cisco switches ranging from the Catalyst 2950 switch to the Catalyst 4506 switch. Through a user-friendly GUI, users can configure and manage switch clusters or standalone switches. Cisco Network Assistant is available at no cost and can be downloaded from this URL:

<http://www.cisco.com/go/networkassistant>

For information on starting the Network Assistant application, see the *Getting Started with Cisco Network Assistant* guide on Cisco.com.

- Device manager

You can use the device manager, which is in the switch memory, to manage individual and standalone switches. Device manager is an easy-to-use web interface that offers quick configuration and monitoring. You can access the device manager from anywhere in your network through a web browser. For more information, see the device manager online help.

- Cisco IOS command-line interface (CLI)

You can manage switches by using command-line entries. To access the CLI, connect a PC or terminal directly to the console port on the switch. If the switch is attached to your network, you can use a Telnet connection to manage the switch from a remote location. For more information, see the switch command reference.

- CiscoView application

You can use the CiscoView device-management application to set configuration parameters and to view switch status and performance information. This application, which you purchase separately, can be a standalone application or part of an Simple Network Management Protocol (SNMP) network-management platform. For more information, see the documentation that came with your CiscoView application.

- SNMP network management

You can manage switches by using an SNMP-compatible management station running platforms such as HP OpenView and SunNet Manager. The switch supports a comprehensive set of MIB extensions and MIB II, the IEEE 802.1D bridge MIB, and four Remote Monitoring (RMON) groups. For more information, see the documentation that came with your SNMP application.

- Cisco Intelligence Engine 2100 (IE2100)
- The Cisco IE200 Series Configuration Registrar is a network management device that works with embedded Cisco Networking Services (CNS) agents in the switch software. You can automate initial configurations and configuration updates by generating switch-specific configuration changes, sending them to the switch, executing the configuration change, and logging the results. For more information, see the switch software configuration guide and the documentation that came with your application.



# Installation

---

This chapter describes how to install your switch, interpret the power-on self-test (POST), and connect the switch to other devices.



## Note

---

If your installation is in a hazardous environment, see [Chapter 4, “Installation in a Hazardous Environment,”](#) for instructions.

---

Read these topics, and perform the procedures in this order:

- [Preparing for Installation, page 3-2](#)
- [Applying the Switch Protective Liner, page 3-10](#)
- [Verifying Switch Operation, page 3-11](#)
- [Connecting the Switch to the Power Converter, page 3-29](#)
- [Wiring the External Alarm Device Relays, page 3-48](#)
- [Installing the Switch on a DIN Rail, page 3-52](#)
- [Installing the Switch in a Rack, page 3-57](#)
- [Removing the Switch from a DIN Rail or a Rack, page 3-59](#)
- [Connecting to 10/100 and 10/100/1000 Ports, page 3-62](#)
- [Connecting to 100BASE-FX MM Ports, page 3-65](#)
- [Connecting to 100BASE-LX SM Ports, page 3-67](#)
- [Where to Go Next, page 3-69](#)

# Preparing for Installation

This section provides information about these topics:

- [Warnings, page 3-2](#)
- [EMC Regulatory Statements, page 3-6](#)
- [Installation Guidelines, page 3-8](#)
- [Verifying Package Contents, page 3-9](#)

## Warnings

These warnings are translated into several languages in [Appendix C, “Translated Safety Warnings.”](#)



**Warning**

---

**This equipment is to be installed and maintained by service personnel only as defined by AS/NZS 3260 Clause 1.2.14.3 Service Personnel.** Statement 88

---



**Warning**

---

**Only trained and qualified personnel should be allowed to install or replace this equipment.** Statement 49

---



**Warning**

---

**This unit is intended for installation in restricted access areas. A restricted access area can be accessed only through the use of a special tool, lock and key, or other means of security.** Statement 1017

---



**Warning**

---

**Read the installation instructions before you connect the system to its power source.** Statement 1004

---



**Warning**

---

**Do not stack the chassis on any other equipment. If the chassis falls, it can cause severe bodily injury and equipment damage.** Statement 88

---



**Warning**

---

**This equipment is intended for use in a Pollution Degree 2 industrial environment, in overvoltage Category II applications (as defined in IEC publication 60664-1), and at altitudes up to 2000 meters without derating.**  
Statement 1068

---

**Warning**

---

**This equipment is supplied as “open type” equipment. It must be mounted within an enclosure that is suitably designed for those specific environmental conditions that will be present and appropriately designed to prevent personal injury resulting from accessibility to live parts. The interior of the enclosure must be accessible only by the use of a tool.**

**The enclosure must meet IP 54 or NEMA type 4 minimum enclosure rating standards.** Statement 1063

---

**Warning**

---

**Connect the unit only to DC power source that complies with the safety extra-low voltage (SELV) requirements in IEC 60950 based safety standards.**  
Statement 1033

---

**Warning**

---

**Use twisted-pair supply wires suitable for 86°F (30°C) above surrounding ambient temperature outside the enclosure.** Statement 1067

---

**Warning**

---

**To prevent the switch from overheating, do not operate it in an area that exceeds the maximum recommended ambient temperature of 140°F (60°C). To prevent airflow restriction, allow at least 3 inches (7.6 cm) of clearance around the ventilation openings.** Statement 17C

---

**Warning**

---

**When installing the unit, always make the ground connection first and disconnect it last.** Statement 42

---

**Warning**

---

**This equipment is intended to be grounded. Ensure that the host is connected to earth ground during normal use.** Statement 39

---

**Warning**

---

**This equipment is intended to be grounded to comply with emission and immunity requirements. Ensure that the switch functional ground lug is connected to earth ground during normal use.** Statement 1064

---

**Warning**

---

**Before working on equipment that is connected to power lines, remove jewelry (including rings, necklaces, and watches). Metal objects will heat up when connected to power and ground and can cause serious burns or weld the metal object to the terminals.** Statement 43

---

**Warning**

---

**To prevent bodily injury when mounting or servicing this unit in a rack, you must take special precautions to ensure that the system remains stable. The following guidelines are provided to ensure your safety:**

- **This unit should be mounted at the bottom of the rack if it is the only unit in the rack.**
  - **When mounting this unit in a partially filled rack, load the rack from the bottom to the top with the heaviest component at the bottom of the rack.**
  - **If the rack is provided with stabilizing devices, install the stabilizers before mounting or servicing the unit in the rack.** Statement 1006
- 

**Warning**

---

**Before performing any of the following procedures, ensure that power is removed from the DC circuit. To ensure that all power is OFF, locate the circuit breaker on the panel board that services the DC circuit, switch the circuit breaker to the OFF position, and tape the switch handle of the circuit breaker in the OFF position.** Statement 140

---



Warning

**An exposed wire lead from a DC-input power source can conduct harmful levels of electricity. Be sure that no exposed portion of the DC-input power source wire extends from the power and relay connector.** Statement 122



Warning

**Do not work on the system or connect or disconnect cables during periods of lightning activity.** Statement 1001



Warning

**When used in a Class I, Division 2, hazardous location, this equipment must be mounted in a suitable enclosure with proper wiring method, for all power, input and output wiring, that complies with the governing electrical codes and in accordance with the authority having jurisdiction over Class I, Division 2 installations.** Statement 1066



Warning

**Ultimate disposal of this product should be handled according to all national laws and regulations.** Statement 180



Warning

**Class 1 laser product.** Statement 1008



Warning

**Class 1 LED product.** Statement 1027



Warning

**Invisible laser radiation may be emitted from disconnected fibers or connectors. Do not stare into beams or view directly with optical instruments.** Statement 1051



Warning

**For diverging beams, viewing the laser output with certain optical instruments within a distance of 100 mm may harm your eyes. For collimated beams, viewing the laser output with certain optical instruments designed for use at a distance may harm your eyes.** Statement 282

**Warning**

---

**Avoid direct exposure to the laser beam.** Statement 1012

---

**Caution**

---

This equipment is suitable for use in Class I, Division 2, Groups A, B, C, D, or non-hazardous locations only.

---

## EMC Regulatory Statements

This section includes specific regulatory statements about the Catalyst 2955 family of switches.

### U.S.A.

U.S. regulatory information for this product is in the front matter of this manual.

### Class A Notice for Taiwan and Other Traditional Chinese Markets

**Warning**

---

**This is a Class A Information Product, when used in residential environment, it may cause radio frequency interference, under such circumstances, the user may be requested to take appropriate countermeasures.** Statement 257

---

**警告**

這是甲類資訊產品，在居住環境中使用時，可能會造成射頻干擾，在這種情況下，使用者會被要求採取某些適當的對策。

---

## VCCI Class A Notice for Japan



### Warning

**This is a Class A product based on the standard of the Voluntary Control Council for Interference by Information Technology Equipment (VCCI). If this equipment is used in a domestic environment, radio disturbance may arise. When such trouble occurs, the user may be required to take corrective actions.** Statement 191

### 警告

これは、情報処理装置等電波障害自主規制協議会（VCCI）の規定に基づくクラスA装置です。この装置を家庭環境で使用すると、電波妨害を引き起こすことがあります。この場合には、使用者が適切な対策を取るようにより要求されることがあります。

## Class A Warning for Korea



### Warning

**This is a Class A Device and is registered for EMC requirements for industrial use. The seller or buyer should be aware of this. If this type was sold or purchased by mistake, it should be replaced with a residential-use type.** Statement 294

### 주의

A급 기기 이 기기는 업무용으로 전자파 적합 등록을 한 기기이오니 판매자 또는 사용자는 이 점을 주의하시기 바라며 만약 잘못 판매 또는 구입하였을 때에는 가정용으로 교환하시기 바랍니다.

## Class A Warning for Hungary



### Warning

**This equipment is a class A product and should be used and installed properly according to the Hungarian EMC Class A requirements (MSZEN55022). Class A equipment is designed for typical commercial establishments for which special conditions of installation and protection distance are used.** Statement 256

### Figyelem

**Figyelmeztetés a felhasználói kézikönyv számára: Ez a berendezés "A" osztályú termék, felhasználására és üzembe helyezésére a magyar EMC "A" osztályú követelményeknek (MSZ EN 55022) megfelelően kerülhet sor, illetve ezen "A" osztályú berendezések csak megfelelő kereskedelmi forrásból származhatnak, amelyek biztosítják a megfelelő speciális üzembe helyezési körülményeket és biztonságos üzemelési távolságok alkalmazását.**

## Installation Guidelines

When determining where to place the switch, observe these guidelines.

- Before installing the switch, first verify that the switch is operational by powering it on and running POST. Follow the procedures in the [“Powering On the Switch and Running POST”](#) section on page 3-13.
- For 10/100 ports and 10/100/1000 ports, the cable length from a switch to an attached device cannot exceed 328 feet (100 meters).
- For 100BASE-FX multimode fiber-optic (MM) ports, the cable length from a switch to an attached device cannot exceed 6562 feet (2 kilometers).
- For 100BASE-LX single-mode fiber-optic (SM) ports, the cable length from a switch to an attached device cannot exceed 9.375 miles (15 kilometers).
- Operating environment is within the ranges listed in [Appendix A, “Technical Specifications.”](#)

- Clearance to front and rear panels meet these conditions:
  - Front-panel LEDs can be easily read.
  - Access to ports is sufficient for unrestricted cabling.
  - Front-panel direct current (DC) power and relay connector is within reach of the connection to the DC power source.
- Airflow around the switch and through the vents is unrestricted. To prevent the switch from overheating, there must be a minimum of 3 inches between any other device and the top, bottom, or sides of the switch.
- Temperature surrounding the unit does not exceed 140°F (60°C).

**Note**

---

When the switch is installed in an industrial enclosure, the temperature within the enclosure is greater than normal room temperature outside the enclosure.

The temperature inside the enclosure cannot exceed 140°F (60°C), the maximum ambient enclosure temperature of the switch.

---

- Cabling is away from sources of electrical noise, such as radios, power lines, and fluorescent lighting fixtures.

## Verifying Package Contents

**Note**

---

Carefully remove the contents from the shipping container, and check each item for damage. If any item is missing or damaged, contact your Cisco representative or reseller for support. Return all packing materials to the shipping container and save them.

---

The switch is shipped with these items:

- *Catalyst 2955 Hardware Installation Guide* (Cisco part number DOC-7814944=)
- Power and relay connector
- Switch installation protective liner

- One ferrite
- One RJ-45-to-DB-9 console port adapter cable

**Note**

---

To connect the switch functional ground, you need a ring terminal lug (such as Thomas & Bett part number RC10-14 or equivalent).

---

If you want to connect a terminal to the switch console port, you need to provide an RJ-45-to-DB-25 female DTE adapter. You can order a kit (part number ACS-DSBUASYN=) with that adapter from Cisco.

For multimode (MM) connections, you can connect a 100BASE-FX port to a port on a target device by using one of the MT-RJ fiber-optic patch cables listed in [Table B-1 on page B-3](#). Use the Cisco part numbers in [Table B-1](#) to order the patch cables that you need.

For single-mode (SM) connections, you can connect a 100BASE-LX port to a port on a target device by using one of the connectors listed in [Table B-2 on page B-4](#). Use the Cisco part numbers in [Table B-2](#) to order the patch cables that you need.

## Applying the Switch Protective Liner

The switch ships with a protective liner that prevents debris from falling into the switch ventilation holes during installation. Before installing the switch on a DIN rail or in a 19-inch rack, connecting the switch to a power source, or wiring the external alarm device relays, you must first apply the protective liner.

Because the protective liner covers ventilation holes on the switch, the liner must be removed from the switch before power is applied to allow proper airflow through the switch chassis.



Follow these steps to apply the protective liner:

- 
- Step 1** Peel the protective liner from the backing.
- Step 2** Apply the protective liner to the switch:
- If you are installing the switch in a parallel mounting position, apply the protective liner to the switch top panel.
  - If you are installing the switch in a face-down mounting position, apply the protective liner to the switch rear panel.
- 

**Caution**

Remove the protective liner before applying power to the switch.

Failure to remove the protective liner could result in thermal damage to the switch.

---

## Verifying Switch Operation

Before installing the switch on a DIN rail or in a 19-inch rack, you should power on the switch and verify that the switch passes POST. These sections describe the steps required to connect a PC to the switch console port, to power on the switch, and to observe POST:

[Connecting a PC or a Terminal to the Console Port, page 3-11](#)

[Powering On the Switch and Running POST, page 3-13](#)

## Connecting a PC or a Terminal to the Console Port

To connect a PC to the console port, use the supplied RJ-45-to-DB-9 adapter cable. To connect a terminal to the console port, you need to provide an RJ-45-to-DB-25 female DTE adapter. You can order a kit (part number ACS-DSBUASYN=) with that adapter from Cisco. For console-port and adapter-pinout information, see the [“Cable and Adapter Specifications” section on page B-5](#).

The PC or terminal must support VT100 terminal emulation. The terminal-emulation software—frequently a PC application such as HyperTerminal or Procomm Plus—makes communication between the switch and your PC or terminal possible during the setup program.

Follow these steps to connect the PC or terminal to the switch:

- 
- Step 1** Make sure that your terminal-emulation software is configured to communicate with the switch through hardware flow control.
- Step 2** Configure the baud rate and data format of the PC or terminal to match these console-port default characteristics:
- 9600 baud
  - Eight data bits
  - One stop bit
  - No parity

After gaining access to the switch, you can change the port baud rate. See the switch software configuration guide for instructions.

- Step 3** Insert the adapter cable in the console port, as shown in [Figure 3-1](#). (See the “[Cable and Adapter Pinouts](#)” section on [page B-9](#) for pinout descriptions.)

**Figure 3-1** Connecting to the Console Port

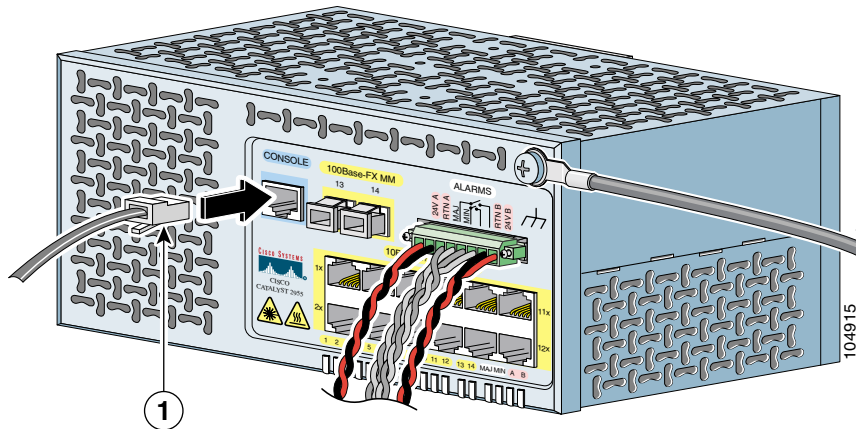

1	Console cable
---	---------------

- Step 4** Attach the appropriate adapter to the terminal, if needed.
- Step 5** Insert the other adapter cable end in the PC or terminal adapter.
- Step 6** Start the terminal-emulation software.

## Powering On the Switch and Running POST

These sections describe the steps required to power on the switch and to observe POST:

[Grounding the Switch, page 3-15](#)

[Wiring the DC Power Source, page 3-17](#)

[Add the Ferrite to the Power and Relay Connector Wiring, page 3-24](#)

[Attach the Power and Relay Connector to the Switch, page 3-25](#)

[Power On the Switch, page 3-27](#)

[Running POST, page 3-27](#)

**Note**

---

The Catalyst 2955 switch can be used with an optional AC/DC power converter (PWR-2955-AC=) in a nonhazardous location installation.

For instructions on how to connect the power converter to the switch, see the [“Connecting the Switch to the Power Converter”](#) section on page 3-29.

---

Locate the power and relay connector, the ferrite, and the switch installation protective liner in the switch kit.

**Note**

---

You can get replacement power and relay connectors (PWR-2955-CONNECT=) by calling Cisco Technical Support. See the [“Obtaining Technical Assistance”](#) section on page xxviii.

---

Obtain these necessary tools and equipment:

- Ratcheting torque flathead screwdriver that exerts up to 15 inch pounds (in-lbs.) of pressure
- Ring terminal lug (such as Thomas & Bett part number RC10-14 or equivalent)
- Crimping tool (such as Thomas & Bett part number WT2000, ERG-2001, or equivalent)
- 10- to 12-gauge copper ground wire (such as Belden part number 9912 or equivalent)
- Wire for power connections:
  - For input AC power connections to the power converter, use a standard 18-gauge AC power cord. See the [“Preparing the AC Power Cord”](#) section on page 3-35 for instructions on how to prepare an AC power cord for use with the power converter.
  - For DC power connections, use UL and CSA rated, style 1007 or 1569 twisted-pair copper appliance wiring material (AWM) wire (such as Belden part number 9318).
- Wire-stripping tools for stripping 10- to 12- and 18-gauge wires

## Grounding the Switch

**Warning**

---

**This equipment is intended to be grounded to comply with emission and immunity requirements. Ensure that the switch functional ground lug is connected to earth ground during normal use.** Statement 1064

---

**Warning**

---

**When installing the unit, always make the ground connection first and disconnect it last.** Statement 42

---

**Caution**

---

To make sure that the equipment is reliably connected to earth ground, follow the grounding procedure instructions, and use a UL-listed ring terminal lug suitable for number-10 to 12 AWG wire, such as Thomas & Bett part number RC10-14 or equivalent.

---

To ground the switch to earth ground by using the functional ground screw, follow these steps. Make sure to follow any grounding requirements at your site.

- 
- Step 1** Use a standard Phillips screwdriver or a ratcheting torque screwdriver with a Phillips head to remove the ground screw from the front panel of the switch. Store the ground screw for later use.
- Step 2** If your ground wire is insulated, use a wire stripping tool to strip the 10- to 12-gauge ground wire to 0.5 inch (12.7 millimeter [mm])  $\pm$  0.02 inch (0.5 mm) as shown in [Figure 3-2](#).

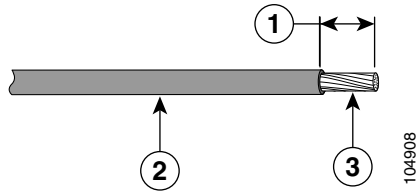
**Figure 3-2** Stripping the Ground Wire

<b>1</b>	0.5 inch (12.7 mm) $\pm$ 0.02 inch (0.5 mm)	<b>3</b>	Wire lead
<b>2</b>	Insulation		

- Step 3** Insert the ground wire into the ring terminal lug, and using a crimping tool, crimp the ring terminal to the wire.

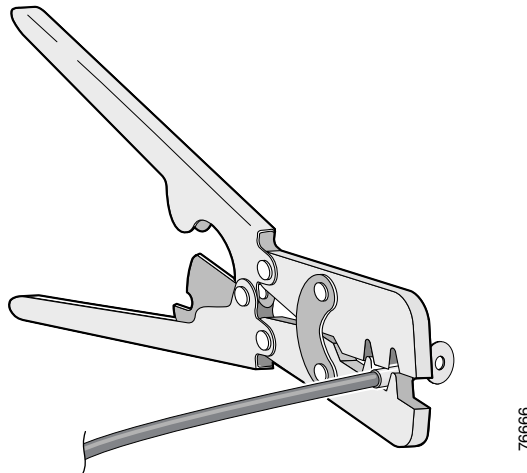
**Figure 3-3** Crimping the Ring Terminal

- Step 4** Slide the ground screw through the ring terminal.
- Step 5** Insert the ground screw into the functional ground screw opening on the front panel.

- Step 6** Using a ratcheting torque screwdriver, tighten the ground screw and ring terminal lug to the switch front panel to 15 in.-lbs. (240 ounce-force inches [ozf-in.]), as shown in [Figure 3-4](#).

**Figure 3-4** Torquing Ground-Lug Screws

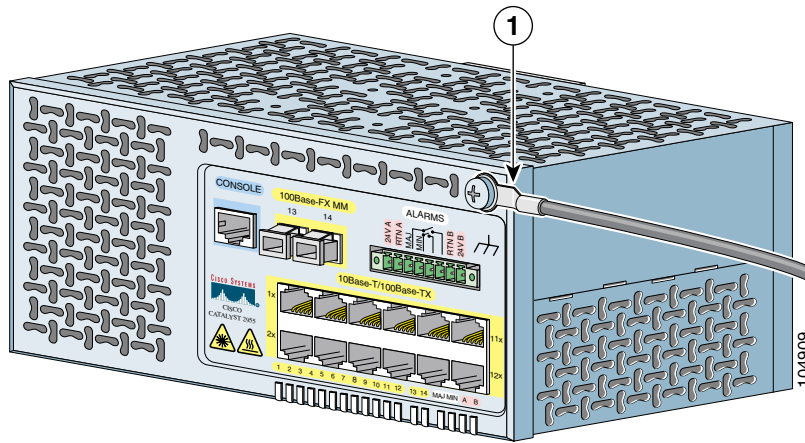

<b>1</b>	Grounding cable
----------	-----------------

- Step 7** Attach the other end of the ground wire to a grounded bare metal surface, such as a ground bus, a grounded DIN rail, or a grounded bare rack.

## Wiring the DC Power Source



**Warning**

**Only trained and qualified personnel should be allowed to install or replace this equipment.** Statement 49

**Warning**

**Before performing any of the following procedures, ensure that power is removed from the DC circuit. To ensure that all power is OFF, locate the circuit breaker on the panel board that services the DC circuit, switch the circuit breaker to the OFF position, and tape the switch handle of the circuit breaker in the OFF position.** Statement 140

**Warning**

**Connect the unit only to DC power source that complies with the safety extra-low voltage (SELV) requirements in IEC 60950 based safety standards.** Statement 1033

**Caution**

You must connect the switch only to a DC-input power source that has an input supply voltage from 18 to 32 VDC. If the supply voltage is not in this range, the switch might not operate properly or might be damaged.

**Caution**

The switch must be installed with 2 A-branch-circuit protection.

**Caution**

This installation must comply with all applicable codes.

**Note**

For wire connections to the power and relay connector, you must use UL and CSA rated, style 1007 or 1569 twisted-pair copper appliance wiring material (AWM) wire (such as Belden part number 9318).

You must also use the ferrite that ships with the switch.

To wire the switch to the optional AC/DC converter, go to the [“Connecting the Switch to the Power Converter”](#) section on page 3-29.



To wire the switch to a DC-input power source, follow these steps:

- Step 1** Locate the power and relay connector (see [Figure 3-5](#)).

**Figure 3-5** Power and Relay Connector

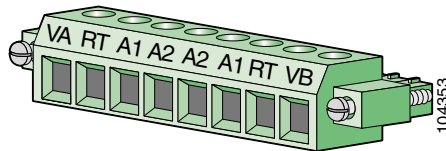

- Step 2** Identify the positive and return feed positions for the power and relay connector. The positive DC power connection from power supply A is labeled VA, and the return is the adjacent connection labeled RT. The positive DC power connection from power supply B (the redundant power supply) is labeled VB, and the return is the adjacent connection labeled RT.
- Step 3** Measure two strands of twisted-pair copper wire (18 to 20 AWG) long enough to connect to the DC power source.
- Step 4** Using an 18-gauge wire-stripping tool, strip each of the two twisted pair wires coming from each DC-input power source to 0.25 inch (6.3 mm)  $\pm$  0.02 inch (0.5 mm). Do not strip more than 0.27 inch (6.8 mm) of insulation from the wire. Stripping more than the recommended amount of wire can leave exposed wire from the power and relay connector after installation.

**Figure 3-6** Stripping the Power Connection Wire

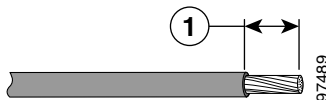

<b>1</b>	0.25 in. (6.3 mm) $\pm$ 0.02 in. (0.5 mm)
----------	---

- Step 5** Insert the exposed DC-input power source wires into the power and relay connector, as shown in [Figure 3-7](#). Make sure that you cannot see any wire lead. Only wire *with insulation* should extend from the connector.

**Warning**

**An exposed wire lead from a DC-input power source can conduct harmful levels of electricity. Be sure that no exposed portion of the DC-input power source wire extends from the power and relay connector.** Statement 122

**Figure 3-7** *Inserting Wires in the Power and Relay Connector*

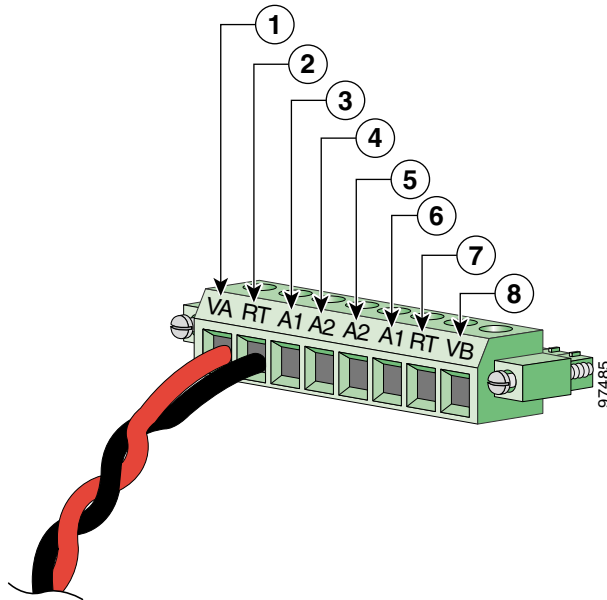

<b>1</b>	Power supply A positive connection	<b>5</b>	External device 2, relay wire B connection
<b>2</b>	Power supply A return connection	<b>6</b>	External device 1, relay wire B connection
<b>3</b>	External device 1, relay wire A connection	<b>7</b>	Power supply B return connection
<b>4</b>	External device 2, relay wire A connection	<b>8</b>	Power supply B positive connection

- Step 6** Use a ratcheting torque flathead screwdriver to torque the power and relay connector captive screws (above the installed wire leads) to 4.5 in-lbs. (72 ozf-in.). (See [Figure 3-8](#).)

**Caution**

Do not overtorque the power and relay connector captive screws. The recommended maximum torque is 4.5 in-lbs.

**Figure 3-8** *Torquing the Power and Relay Connector Captive Screws*

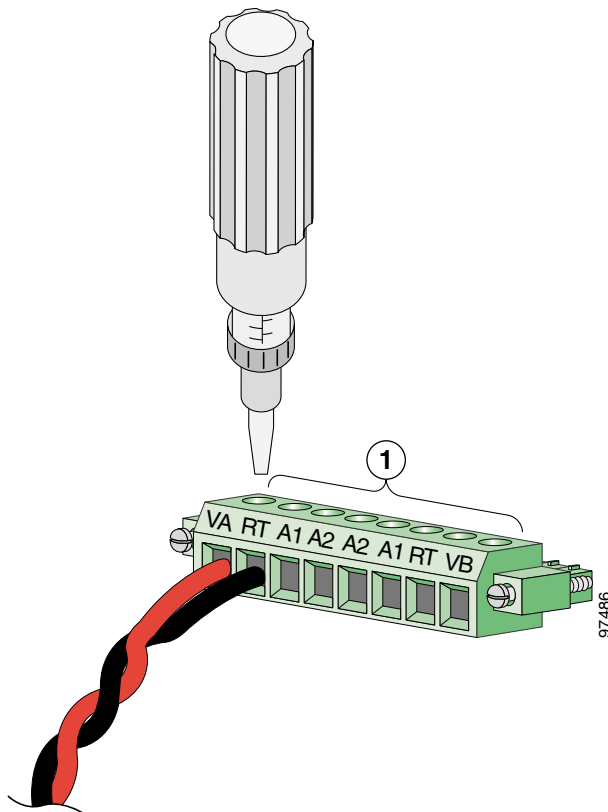

**1** Power and relay connector captive screws

- Step 7** Connect the other end of the wire connected to VA to the positive pole on the DC power source, and connect the other end of the wire connected to RT to the return pole on the DC power source.



---

**Note** If you are connecting a second power supply, repeat [Step 4](#) through [Step 7](#) for the DC-input (VB) and return (RT) for power supply B.

---

[Figure 3-9](#) shows the completed DC-input wiring on a power and relay connector for a primary power supply and an optional secondary power supply.

---

**Figure 3-9** Completed DC Power Connections on the Power and Relay Connector

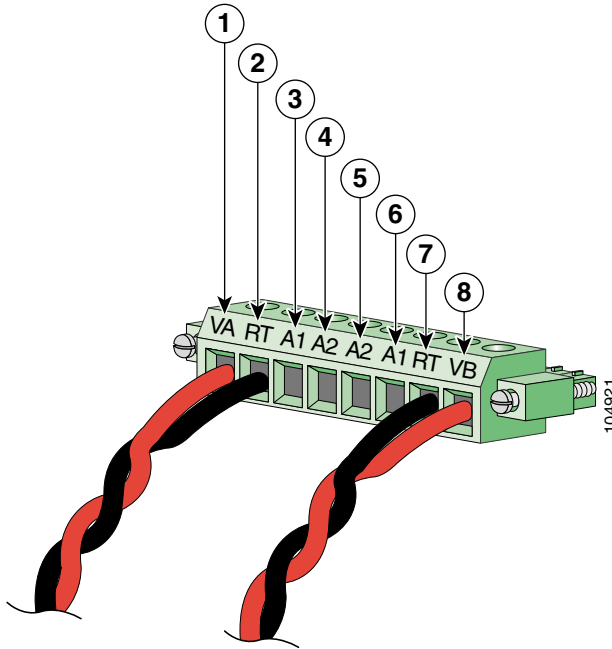

<b>1</b>	Power supply A positive connection	<b>5</b>	External device 2, relay wire B connection
<b>2</b>	Power supply A return connection	<b>6</b>	External device 1, relay wire B connection
<b>3</b>	External device 1, relay wire A connection	<b>7</b>	Power supply B return connection
<b>4</b>	External device 2, relay wire A connection	<b>8</b>	Power supply B positive connection

**Note**

If you plan to connect external alarm devices to the alarm relays, go to the [“Wiring the External Alarm Device Relays”](#) section on page 3-48. Otherwise, go to the next section.

## Add the Ferrite to the Power and Relay Connector Wiring

Before you connect the power and relay connector to the front panel, follow these steps to add a ferrite to the power and relay connector wiring.

- Step 1** Position the opened ferrite around the wiring within 3 inches of the power and relay connector.
- Step 2** Loop the wiring around the ferrite (see [Figure 3-10](#)).

**Figure 3-10** Wire Looped Through the Ferrite

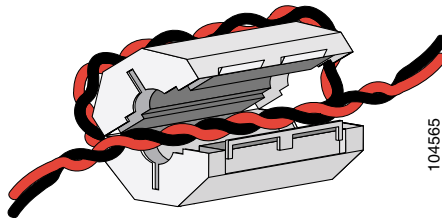

- Step 3** Press the ferrite closed until the clasp snaps shut (see [Figure 3-11](#)).

**Figure 3-11** Clasping the Ferrite

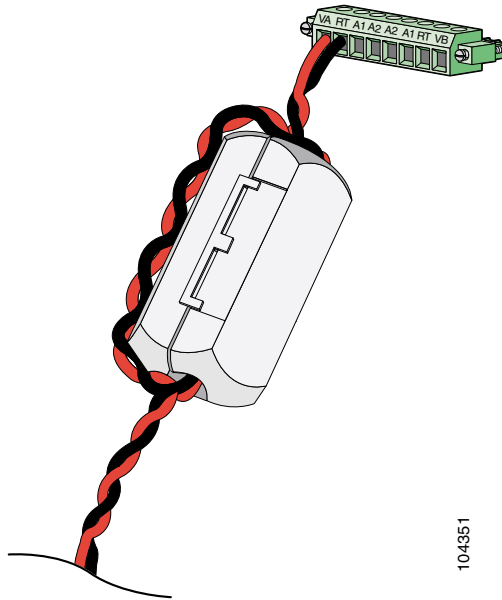

## Attach the Power and Relay Connector to the Switch

Follow these steps to attach the power and relay connector to the front panel of the switch.

- Step 1** Insert the power and relay connector into the power and relay connector receptacle on the switch front panel (see [Figure 3-12](#)).



**Caution**

Secure the wires coming from the power and relay connector so that they cannot be disturbed by casual contact. For example, use tie wraps to secure the wires to the rack.

**Figure 3-12** Connecting the Power and Relay Connector to the Switch

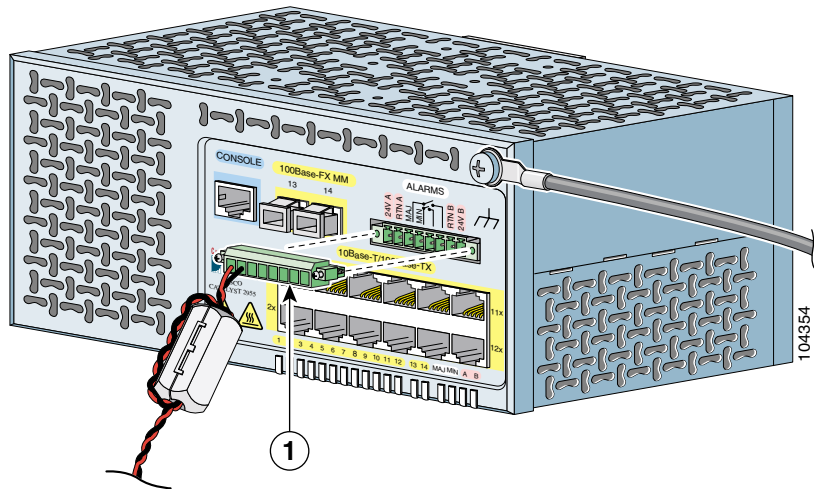

**1** Power and relay connector

**Step 2** Use a flathead screwdriver to tighten the captive screws on the sides of the power and relay connector.



## Power On the Switch

**Caution**

Remove the protective liner before applying power to the switch.

Failure to remove the protective liner could result in thermal damage to the switch.

To apply power to a switch that is directly connected to a DC power source, locate the circuit breaker on the panel board that services the DC circuit, and switch the circuit breaker to the ON position.

**Note**

For instructions on how to apply power to a switch that is connected to a power converter, see the [“Applying Power to the Power Converter”](#) section on page 3-46.

## Running POST

After the power is connected, the switch automatically begins POST, a series of tests that verifies that the switch functions properly.

**Note**

The uplink port status LEDs provide system and status information during POST. On the Catalyst 2955C-12 and 2955S-12, the uplink ports are labeled 13 and 14. On the Catalyst 2955T-12, the uplink ports are labeled 1 and 2.

When the Catalyst 2955C-12 and 2955S-12 begin POST:

- Uplink port 13 LED is amber.
- Uplink port 14 LED blinks green.

When the Catalyst 2955T-12 begins POST:

- Uplink port 1 LED is amber.
- Uplink port 2 LED blinks green.

If POST completes successfully on the Catalyst 2955C-12 and 2955S-12:

- Uplink port 13 LED turns green.
- Uplink port 14 LED goes off during the flash file system initialization.

If POST completes successfully on the Catalyst 2955T-12:

- Uplink port 1 LED turns green.
- Uplink port 2 LED goes off during the flash file system initialization.

If POST fails on the Catalyst 2955C-12 and 2955S-12:

- Uplink port 13 LED blinks amber.
- Uplink port 14 LED turns green.

If POST fails on the Catalyst 2955T-12:

- Uplink port 1 LED blinks amber.
- Uplink port 2 LED turns green.

While the switch powers on, the power status LEDs are green or red, showing the presence or absence of power supplies (see [Table 2-1 on page 2-13](#) for details). During POST, the power status LEDs are green. After POST completes successfully, the power status LEDs are green if both power supplies are functioning normally and the switch has been configured to operate in dual-power mode.

If the switch is in single-power mode and only power supply A is present and functioning, the LED for power supply B is green, and the LED for power supply A shows its status. If the switch is in single-power mode and only power supply B is present and functioning, the LED for power supply A is green, and the LED for power supply B shows its status.

See the switch configuration guide for details on single- and dual-power mode operation.

On a Catalyst 2950 switch, you can use the MODE button to recover the switch password. The Catalyst 2955 switch has no MODE button, so the boot loader compensates by using break key detection to stop the automatic boot sequence for password recovery.

On the Catalyst 2955C-12 and 2955S-12 switches, during the initial appearance of the boot loader prompt on the console after POST, uplink port 13 LED blinks green, and uplink port 14 LED is off. On the Catalyst 2955T-12 switch, during the initial appearance of the boot loader prompt on the console after POST, uplink port 1 LED blinks green, and uplink port 2 LED is off.

**Note**

POST failures are usually fatal. Call Cisco Systems immediately if your switch does not pass POST. See the [“Obtaining Technical Assistance”](#) section on page xxviii.

**Note**

See the switch software configuration guide for details on the Catalyst 2955 switch password recovery process.

After successfully running POST, follow these steps.

- Step 1** Turn off power to the switch.
- Step 2** Disconnect the cables.
- Step 3** Decide where you want to install the switch.

## Connecting the Switch to the Power Converter

The Catalyst 2955 switch can be used with an optional AC/DC power converter (PWR-2955-AC=) in a nonhazardous location installation.

**Caution**

To prevent the Catalyst 2955 switch from overheating, there must be a minimum of 3 inches between any other device and the top, bottom, or sides of the switch.

The power converter requires 1 inch of thermal spacing to prevent overheating. Therefore, there must be a minimum of 4 inches between the power converter and the Catalyst 2955 switch to prevent each device from overheating.

These sections describe the steps required to connect the switch to a power converter:

- [Installing the Power Converter on a DIN Rail, page 3-30](#)
- [Connecting the Power Converter to the Power and Relay Connector, page 3-32](#)

After you connect the switch to the power converter, you must connect the power converter to an AC or a DC power source.

For instructions on connecting the power converter to an AC power source, see [Connecting the Power Converter to an AC Power Source, page 3-35](#). For instructions on connecting the power converter to a DC power source, see [Connecting the Power Converter to a DC Power Source, page 3-41](#).

## Installing the Power Converter on a DIN Rail

Follow these steps to install the power converter on a DIN rail.



### Warning

---

**This equipment is supplied as “open type” equipment. It must be mounted within an enclosure that is suitably designed for those specific environmental conditions that will be present and appropriately designed to prevent personal injury resulting from accessibility to live parts. The interior of the enclosure must be accessible only by the use of a tool.**

**The enclosure must meet IP 54 or NEMA type 4 minimum enclosure rating standards.** Statement 1063

---



### Caution

---

To prevent the Catalyst 2955 switch from overheating, there must be a minimum of 3 inches between any other device and the top, bottom, or sides of the switch.

The power converter requires 1 inch of thermal spacing to prevent overheating. Therefore, there must be a minimum of 4 inches between the power converter and the Catalyst 2955 switch to prevent each device from overheating.

---

- Step 1** Position the power converter directly in front of the DIN rail, making sure that the top of the DIN rail clip meets the top of the DIN rail, as shown in [Figure 3-13](#).

**Figure 3-13** *Mounting the Power Converter on a DIN Rail*

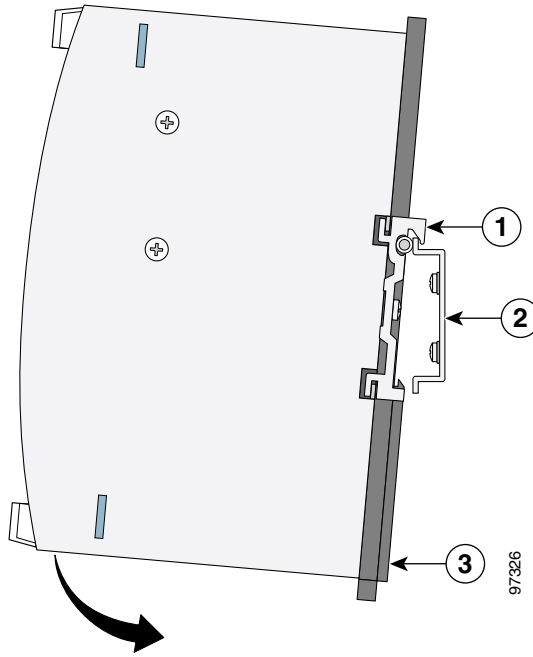

<b>1</b>	DIN rail clip	<b>3</b>	Clip release tab
<b>2</b>	DIN rail		

- Step 2** Rotate the power converter down toward the DIN rail until the release tab on the rear panel clicks.
- Step 3** Press down lightly on the top of the power converter to ensure that it is firmly locked in place.

## Connecting the Power Converter to the Power and Relay Connector

Follow these steps to connect your switch to the power converter.



### Warning

**Use twisted-pair supply wires suitable for 86°F (30°C) above surrounding ambient temperature outside the enclosure.** Statement 1067



### Warning

**This equipment is intended to be grounded to comply with emission and immunity requirements. Ensure that the switch functional ground lug is connected to earth ground during normal use.** Statement 1064



### Caution

To make sure that the switch is reliably connected to earth ground, follow the grounding procedure instructions in the [“Grounding the Switch” section on page 3-15](#), and use a UL-listed lug suitable for number-10 to 12 AWG wire and an M-5 thread ground screw.



### Note

For wire connections to the power and relay connector, you must use UL and CSA rated, style 1007 or 1569 twisted-pair copper appliance wiring material (AWM) wire (such as Belden part number 9318).

You must also use the ferrite that ships with the switch.

- 
- Step 1** Locate the Catalyst 2955 switch power and relay connector (see [Figure 3-5](#)).
- Step 2** Identify the positive and return feed positions for the power and relay connector. The positive DC power connection from power supply A is labeled VA, and the return is the adjacent connection labeled RT. The positive DC power connection from power supply B (the secondary power supply) is labeled VB, and the return is the adjacent connection labeled RT.

- Step 3** Measure a strand of twisted-pair copper wire (18 AWG) long enough to connect the power converter to the switch. Ensure that the wire is long enough to loop through the ferrite and still maintain 4 inches of thermal spacing between the switch and the power converter.
- Step 4** Using an 18-gauge wire-stripping tool, strip both ends of the twisted pair wires to 0.25 inch (6.3 mm)  $\pm$  0.02 inch (0.5 mm). Do not strip more than 0.27 inch (6.8 mm) of insulation from the wire. Stripping more than the recommended amount of wire can leave exposed wire from the power and relay connector after installation. (See [Figure 3-6](#).)
- Step 5** Insert the exposed wires into the power and relay connector, as shown in [Figure 3-7](#). Make sure that you cannot see any exposed wire. Only wire *with insulation* should extend from the connection.

**Warning**

---

**An exposed wire lead from a DC-input power source can conduct harmful levels of electricity. Be sure that no exposed portion of the DC-input power source wire extends from the power and relay connector.** Statement 122

---

- Step 6** Use a ratcheting torque flathead screwdriver to torque the power and relay connector captive screw (above the installed wire leads) to 4.5 in-lbs. (72 ozf-in.). (See [Figure 3-8](#).)

**Caution**

---

Do not overtorque the power and relay connector captive screws. The recommended maximum torque is 4.5 in-lbs.

---

- Step 7** Connect the other end of the positive wire (connected to VA) to the far-left power converter DC positive-output connection, and connect the other end of the return wire (connected to RT) to the far-left power converter return-output connection.
- Step 8** Tighten the terminal block screws. (See [Figure 3-14](#).)

**Figure 3-14** Connecting Wires to the Power Converter DC Output Terminal Block

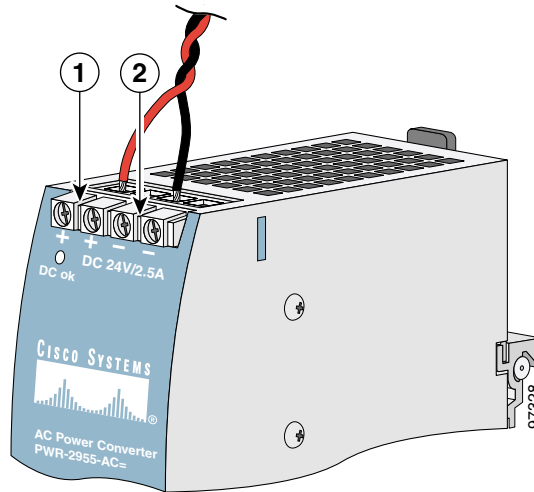

<b>1</b>	DC output positive wire connections	<b>2</b>	DC output return wire connections
----------	-------------------------------------	----------	-----------------------------------

If you are connecting a second power supply, repeat [Step 2](#) through [Step 7](#), using the positive connection (VB) and return connection (RT) on the power and relay connector for power supply B.



**Note**

If you plan to connect external alarm devices to the alarm relays, go to the [“Wiring the External Alarm Device Relays”](#) section on page 3-48.

Before you connect the power and relay connector to the switch front panel, follow the steps in the [“Add the Ferrite to the Power and Relay Connector Wiring”](#) section on page 3-24 to add a ferrite to the power and relay connector wiring.

Follow the steps in the [“Attach the Power and Relay Connector to the Switch”](#) section on page 3-25 to attach the power and relay connector to the front panel of the switch.



## Connecting the Power Converter to an AC Power Source

These sections describe the steps required to connect the power converter to an AC power source:

- [Preparing the AC Power Cord, page 3-35](#)
- [Connecting the AC Power Cord to the Power Converter, page 3-37](#)

### Preparing the AC Power Cord

To connect the power converter to an AC power source, you need a standard AC power cord. Power cord connector types vary by country. Check with your electrical equipment supplier to obtain a cord that meets your site electrical requirements. Power cord color codes also vary by country, as shown in [Table 3-1](#).

**Table 3-1** AC Power Cord Color Codes

<b>Europe (International)</b>	
<b>Color</b>	<b>Meaning</b>
Brown	Line
Blue	Neutral
Green/yellow	Earth ground
<b>United States</b>	
<b>Color</b>	<b>Meaning</b>
Black	Line
White	Neutral
Green	Earth ground

Follow these steps to prepare an AC power cord to connect to the power converter.



**Warning**

**When installing the unit, always make the ground connection first and disconnect it last.** Statement 42

- Step 1** Cut off the female connector on the cord.
- Step 2** Using a wire-stripping tool, strip the outer insulation layer 1 inch (2.54 cm).
- Step 3** Strip the inner wire insulation to 0.25 inch (6.3 mm)  $\pm$  0.02 inch (0.5 mm), as shown in [Figure 3-15](#).

**Figure 3-15** Preparing the AC Power Cord

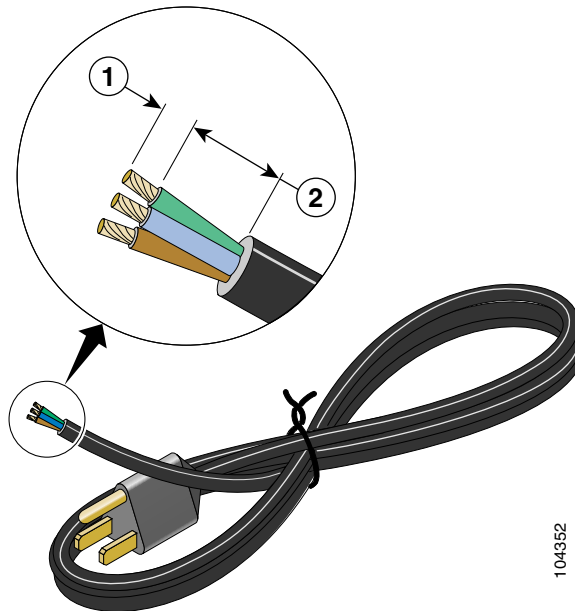

104352

<b>1</b>	0.25 inch (6.35 mm)	<b>2</b>	0.75 inch (19.05 mm)
----------	---------------------	----------	----------------------

## Connecting the AC Power Cord to the Power Converter

Follow these steps to connect the AC power cord to the power converter.



### Caution

AC power sources must be dedicated AC branch circuits. Each branch circuit must be protected by a dedicated two-pole circuit breaker.

### Step 1

Insert the exposed ground wire lead into the power converter ground wire connection. Ensure that only wire *with insulation* extends from the connector.

### Step 2

Tighten the ground wire terminal block screw.



### Caution

Do not insert the cord into the AC outlet until you have completed wiring the line, neutral, and ground connections.

**Figure 3-16** AC/DC Power Input Terminal Block and Input Voltage Selector

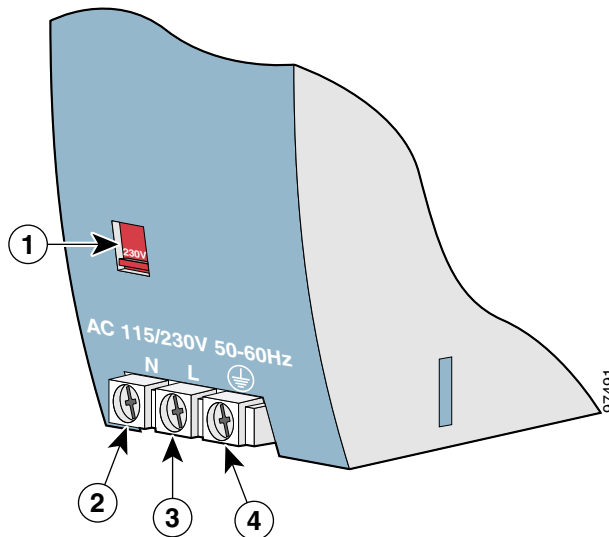

<b>1</b>	Input voltage selector	<b>3</b>	Line wire connection
<b>2</b>	Neutral wire connection	<b>4</b>	Earth ground wire connection

## Connecting the Switch to the Power Converter

- Step 3** Insert the line and neutral wire leads into the terminal block line and neutral connections (see [Figure 3-17](#)). Make sure that you cannot see any wire lead. Ensure that only wire *with insulation* extends from the connectors.
- Step 4** Tighten the line and neutral terminal block screws.

**Figure 3-17** Connecting AC Power to the Power Converter

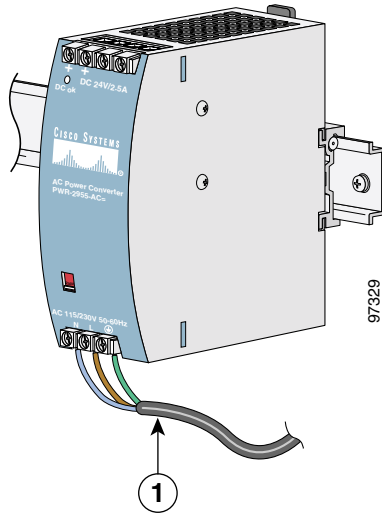

<b>1</b>	To AC power source
----------	--------------------

- Step 5** Set the input voltage selector on the power converter to 115 or 230 V, depending on your country voltage settings or the requirements for the AC receptacle that you are using. (See [Table 3-2](#).)
- Step 6** Connect the other end of the AC power cord to the AC outlet.

[Table 3-2](#) lists power converter input voltages and the corresponding input voltage selector settings.

**Table 3-2** *Input Voltage Selector Settings*

<b>AC/DC in</b>	<b>Input voltage selector setting</b>	<b>Output Current</b>
176 to 264 VAC	230 V	2.5 A
95 to 176 VAC	230 V	1.5 A
85 to 132 VAC	115 V	2.5 A
160 to 375 VDC	230 V	2.5 A
120 to 160 VDC	230 V	2 A
80 to 120 VDC	230 V	1.5 A

Figure 3-18 shows the completed wiring for the power converter and a Catalyst 2955 switch.

**Figure 3-18** The Power Converter Connected to the Catalyst 2955 Switch and an AC Power Source

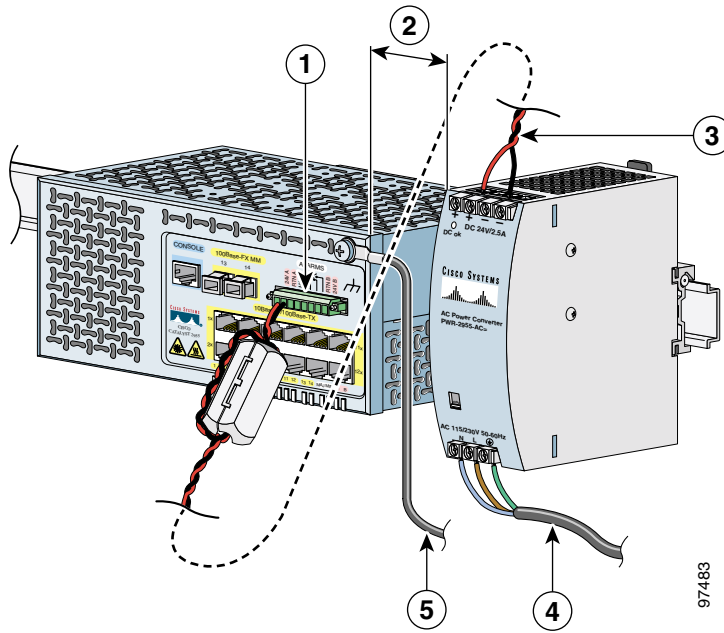

97483

<b>1</b>	Power and relay connector	<b>4</b>	To AC power source
<b>2</b>	4 inches of thermal spacing	<b>5</b>	Switch functional ground connection
<b>3</b>	DC output wires		

## Connecting the Power Converter to a DC Power Source

You can also connect the power converter to a DC power source. The power converter derates the power source voltage to provide 24 VDC to the switch.

**Note**

---

To power on the switch, the input voltage to the power converter must be at least 95 VDC. To ensure proper operation after the Catalyst 2955 switch has powered on, the input voltage to the power converter cannot drop below 80 VDC.

To guarantee 24 VDC at 2.5 A to the Catalyst 2955 switch, the input power to the power converter must remain between 160 and 375 VDC.

---

[Figure 3-19](#) shows a basic wiring diagram for connecting a power converter to a DC power source.

Figure 3-19 Power Converter Connected to a DC Power Source

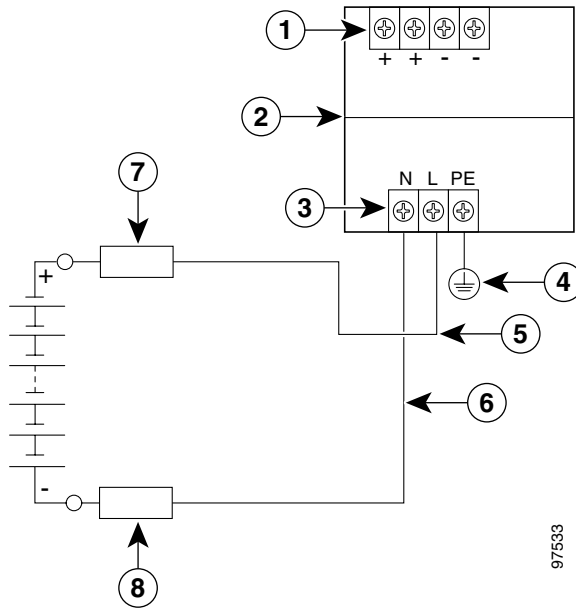

<b>1</b>	DC out	<b>5</b>	Positive
<b>2</b>	Power converter	<b>6</b>	Return
<b>3</b>	AC/DC input terminal block	<b>7</b>	Fuse rated to 600 VAC/DC
<b>4</b>	Earth ground	<b>8</b>	Fuse rated to 600 VAC/DC

Follow these steps to connect the power converter to a DC power source.



**Warning**

**Use twisted-pair supply wires suitable for 86°F (30°C) above surrounding ambient temperature outside the enclosure.** Statement 1067



**Warning**

**When installing the unit, always make the ground connection first and disconnect it last.** Statement 42



---

**Step 1** Measure a single length of green, stranded copper wire long enough to connect the power converter to the earth ground.



---

**Note** For connections from the power converter to earth ground, use shielded 12 AWG stranded copper wire, such as Belden part number 9912 or the equivalent.

---

**Step 2** Measure a length of twisted-pair copper wire long enough to connect the power converter to the DC power source.



---

**Note** For DC connections from the power converter to the DC source, use 12 AWG twisted-pair copper wire, such as Belden part number 9344 or the equivalent.

---

**Step 3** Using a 12-gauge wire-stripping tool, strip the ground wire and both ends of the twisted pair wires to 0.25 inch (6.3 mm)  $\pm$  0.02 inch (0.5 mm). Do not strip more than 0.27 inch (6.8 mm) of insulation from the wires. Stripping more than the recommended amount of wire can leave exposed wire from the power and relay connector after installation. (See [Figure 3-2](#).)

**Step 4** Connect one end of the green, stranded copper wire to a grounded bare metal surface, such as a ground bus, a grounded DIN rail, or a grounded bare rack.

**Step 5** Insert the other end of the exposed ground wire lead into the Earth ground wire connection on the power converter terminal block. Only wire *with insulation* should extend from the connection. (See [Figure 3-20](#).)

**Step 6** Tighten the earth ground wire connection terminal block screw.

**Figure 3-20 AC/DC Power Input Terminal Block Wire Connections to a DC Source**

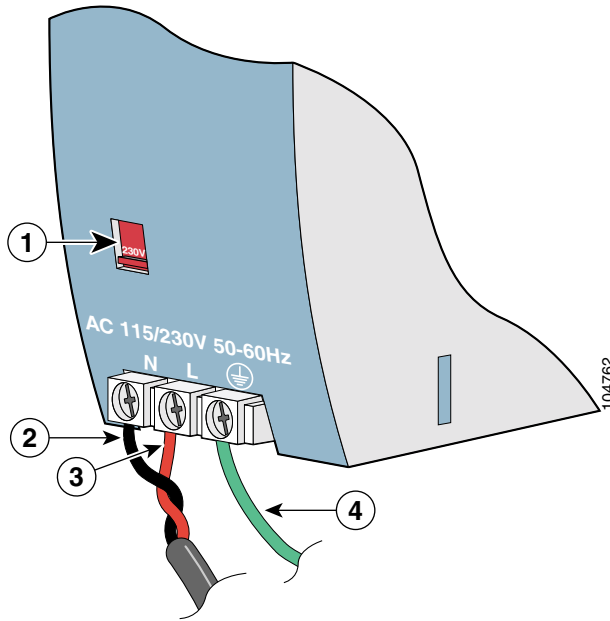

<b>1</b>	Input voltage selector	<b>3</b>	Positive wire connection
<b>2</b>	Return wire connection (to DC return)	<b>4</b>	Earth ground wire connection



### Warning

**An exposed wire lead from a DC-input power source can conduct harmful levels of electricity. Be sure that no exposed portion of the DC-input power source wire extends from the power and relay connector.** Statement 122

- Step 7** Insert the twisted-pair wire leads into the terminal block line and neutral connections. Insert the black wire lead into the neutral wire connection and the red wire lead into the line wire connection. Ensure that only wire *with insulation* extends from the connectors. (See [Figure 3-20](#).)
- Step 8** Tighten the line and neutral terminal block screws.

- Step 9** Connect the red wire to the positive pole of the DC power source, and connect the black wire to the return pole. Ensure that each pole has a current-limiting-type fuse rated to at least 600 VAC/DC (such as the KLKD Midget fuse).
- Step 10** Set the input voltage selector on the power converter to 230 V.

Figure 3-21 shows the completed wiring for the power converter and a Catalyst 2955 switch.

**Figure 3-21** *The Power Converter Connected to the Catalyst 2955 Switch and a DC Power Source*

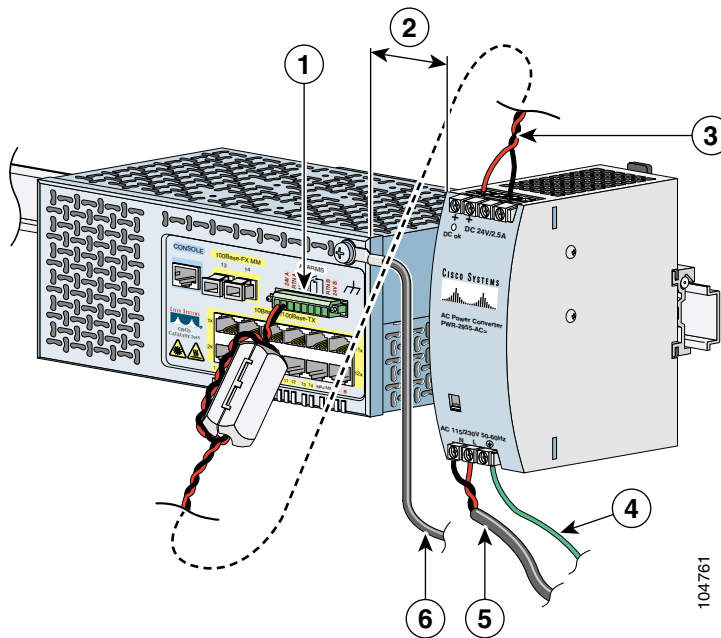

<b>1</b>	Power and relay connector	<b>4</b>	To earth ground
<b>2</b>	4 inches of thermal spacing	<b>5</b>	DC input wires
<b>3</b>	DC output wires	<b>6</b>	Switch functional ground connection

## Applying Power to the Power Converter

**Caution**

---

Remove the protective liner before applying power to the switch.

Failure to remove the protective liner could result in thermal damage to the switch.

---

Move the circuit breaker for the AC outlet or the DC control circuit to the on position.

The LED on the power converter front panel is green when the unit is operating normally. The LED is off when the unit is not operating normally.

After the power is connected, the switch automatically begins the power-on self test (POST), a series of tests that verifies that the switch functions properly. For instructions on how to interpret POST results, see the [“Running POST” section on page 3-27](#).

## Removing the Power Converter from a DIN Rail

Follow these steps to remove the power converter from a DIN rail.

- 
- Step 1** Ensure that power to the power converter is off, and disconnect all cables connecting the power converter to the switch.
- Step 2** Insert a long flathead screwdriver into the tab slot at the bottom of the power converter, and pull down the clip release tab. As the clip releases, lift the bottom of the power converter, as shown in [Figure 3-22](#).

**Figure 3-22** *Removing the Power Converter from a DIN Rail*

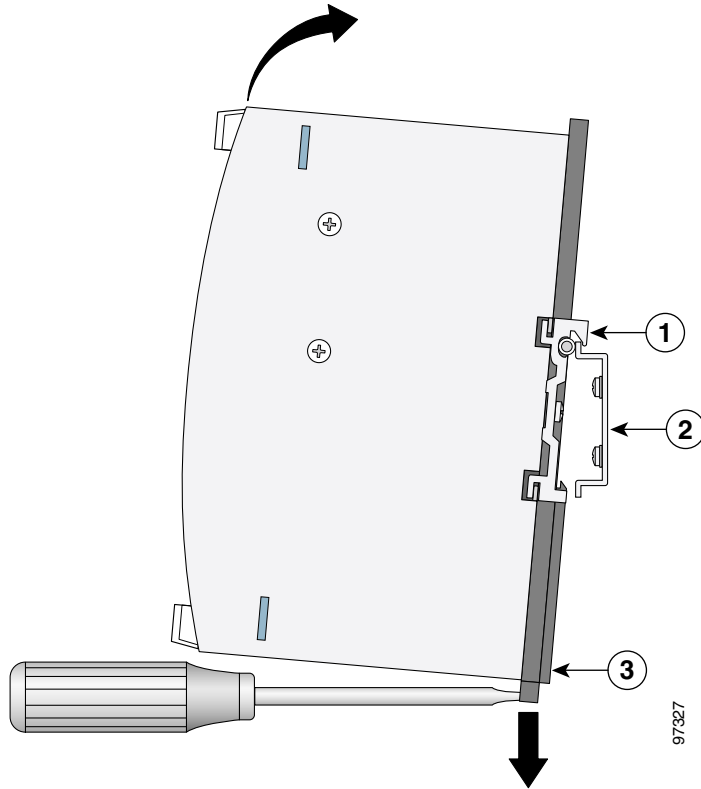

<b>1</b>	DIN rail clip	<b>3</b>	Clip release tab
<b>2</b>	DIN rail		

# Wiring the External Alarm Device Relays

The alarm relays on the Catalyst 2955 switch are normally open (NO). To connect an external alarm device to the relays, you must connect two relay contact wires to complete an electrical circuit. Because each external alarm device requires two connections to a relay, the Catalyst 2955 switch supports a maximum of two external alarm devices.

**Note**

---

For wire connections to the power and relay connector, you must use UL and CSA rated, style 1007 or 1569 twisted-pair copper appliance wiring material (AWM) wire (such as Belden part number 9318).

---

You must also use the ferrite that ships with the switch.

---

After you have completed the wiring for the power connections, follow these steps to wire the switch to an external alarm device:

**Note**

---

This procedure is optional.

---

- 
- Step 1** Measure two strands of twisted-pair wire (18 to 20 AWG) long enough to connect to the external alarm device.
- Step 2** Use a wire stripper to remove the casing from both ends of each wire to 0.25 inch (6.3 mm) ± 0.02 inch (0.5 mm). Do not strip more than 0.27 inch (6.8 mm) of insulation from the wires. Stripping more than the recommended amount of wire can leave exposed wire from the power and relay connector after installation.
- Step 3** Insert the exposed wires for the external alarm device into the two connections labeled A1, as shown in [Figure 3-23](#).

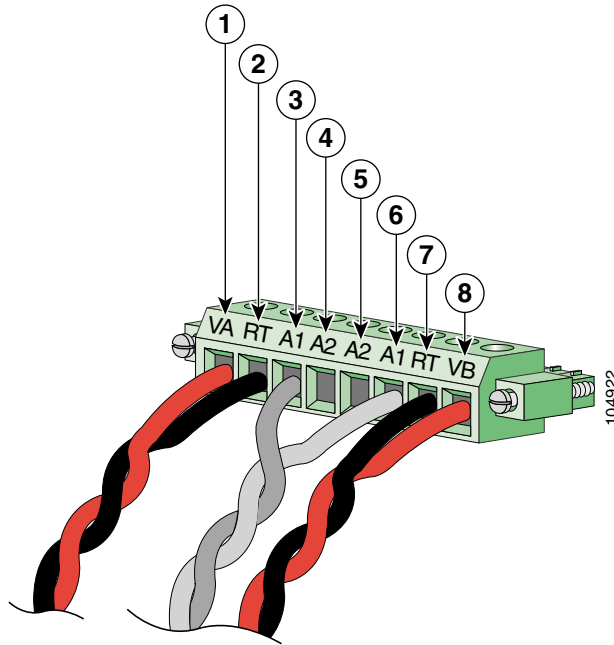
**Figure 3-23** Inserting Relay Wires into the Power and Relay Connector

<b>1</b>	Power supply A positive connection	<b>5</b>	External device 2, relay wire B connection
<b>2</b>	Power supply A return connection	<b>6</b>	External device 1, relay wire B connection
<b>3</b>	External device 1, relay wire A connection	<b>7</b>	Power supply B return connection
<b>4</b>	External device 2, relay wire A connection	<b>8</b>	Power supply B positive connection

- Step 4** Use a ratcheting torque flathead screwdriver to torque the power and relay connector captive screw (above the installed wire leads) to 4.5 in-lbs. (72 ozf-in.). (See [Figure 3-24](#) for details.)

**Caution**

Do not overtorque the power and relay connector captive screws. The recommended maximum torque is 4.5 in-lbs.

**Figure 3-24** Torquing the Power and Relay Connector Captive Screws

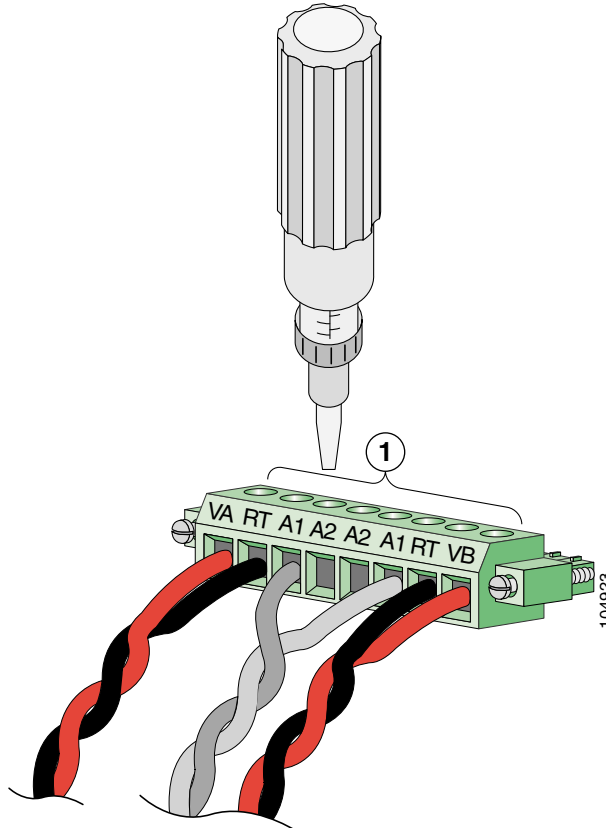

<b>1</b>	Power and relay connector captive screws
----------	--

**Step 5** Repeat [Step 1](#) through [Step 4](#) to insert the input and output wires of an additional external alarm device into the two connections labeled A2.



Figure 3-25 shows the completed wiring for two power supplies and two external alarm devices on a power and relay connector.

**Figure 3-25** Completed Connections for Two External Alarm Devices on the Power and Relay Connector

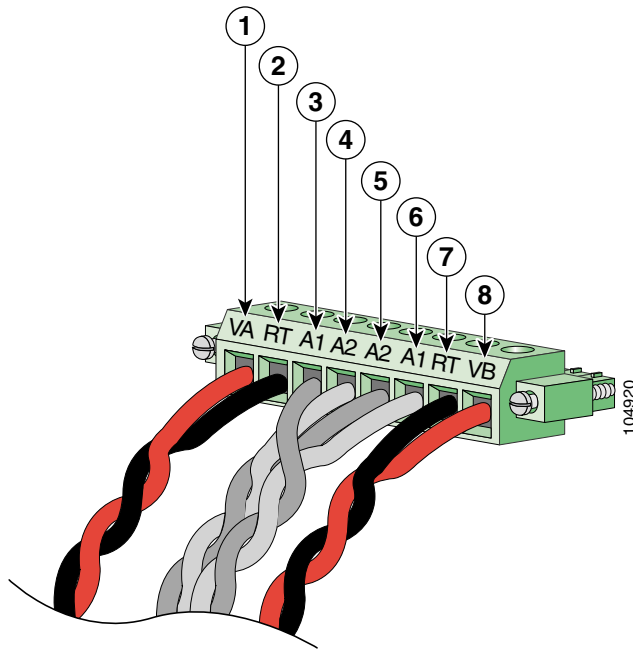

<b>1</b>	Power supply A positive connection	<b>5</b>	External device 2, relay wire B connection
<b>2</b>	Power supply A return connection	<b>6</b>	External device 1, relay wire B connection
<b>3</b>	External device 1, relay wire A connection	<b>7</b>	Power supply B return connection
<b>4</b>	External device 2, relay wire A connection	<b>8</b>	Power supply B positive connection

**Note**

---

See the “[Add the Ferrite to the Power and Relay Connector Wiring](#)” section on [page 3-24](#) for instructions on how to attach the ferrite to the power and relay connector wiring.

See the “[Attach the Power and Relay Connector to the Switch](#)” section on [page 3-25](#) for instructions on how to connect the power and relay connector to the front panel.

---

## Installing the Switch on a DIN Rail

You can mount the Catalyst 2955 switch on a DIN rail in a parallel or a face-down position.

**Warning**

---

**This equipment is supplied as “open type” equipment. It must be mounted within an enclosure that is suitably designed for those specific environmental conditions that will be present and appropriately designed to prevent personal injury resulting from accessibility to live parts. The interior of the enclosure must be accessible only by the use of a tool.**

**The enclosure must meet IP 54 or NEMA type 4 minimum enclosure rating standards.** Statement 1063

---

**Caution**

---

To prevent the switch from overheating, there must be a minimum of 3 inches between any other device and the top, bottom, or sides of the switch.

---

The switch ships with the clip assembly installed on the rear panel for a parallel mounting position, as shown in [Figure 3-26](#). To mount the switch in a face-down position, remove the clip assembly from the rear panel, and install it on the top of the switch, as shown in [Figure 3-27](#).

Figure 3-26 Catalyst 2955 Switch Rear Panel

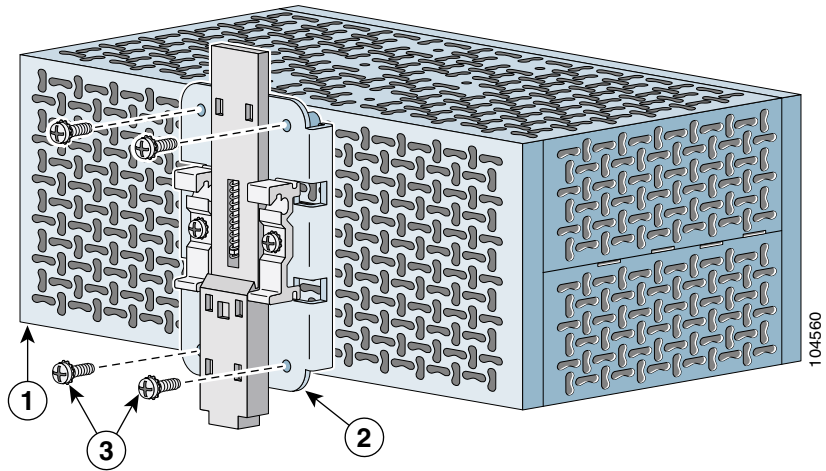

<b>1</b>	Catalyst 2955 switch rear panel	<b>3</b>	DIN rail clip mounting screws
<b>2</b>	DIN rail clip assembly		

**Figure 3-27 Catalyst 2955 Switch Top Panel**

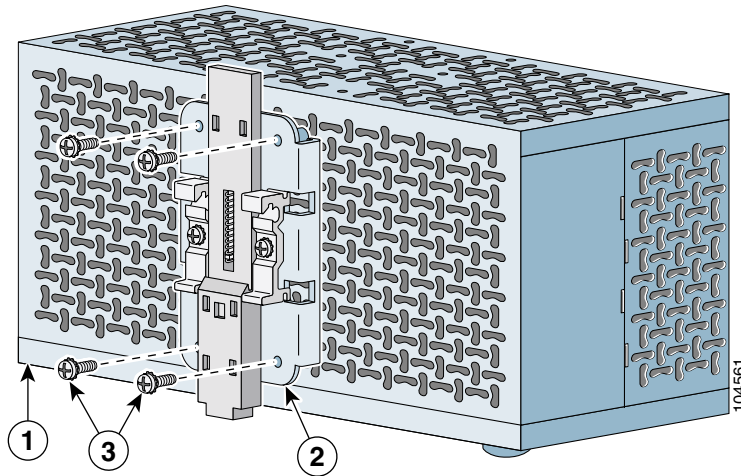

<b>1</b>	Catalyst 2955 switch top panel	<b>3</b>	DIN rail clip mounting screws
<b>2</b>	DIN rail clip assembly		

To attach the switch to a DIN rail, follow these steps.

- Step 1** Position the rear panel of the switch directly in front of the DIN rail, making sure that the top of the DIN rail clip hooks over the top of the DIN rail, as shown in [Figure 3-28](#) and [Figure 3-29](#).

**Figure 3-28** *Mounting the Switch on a DIN Rail in a Parallel Position*

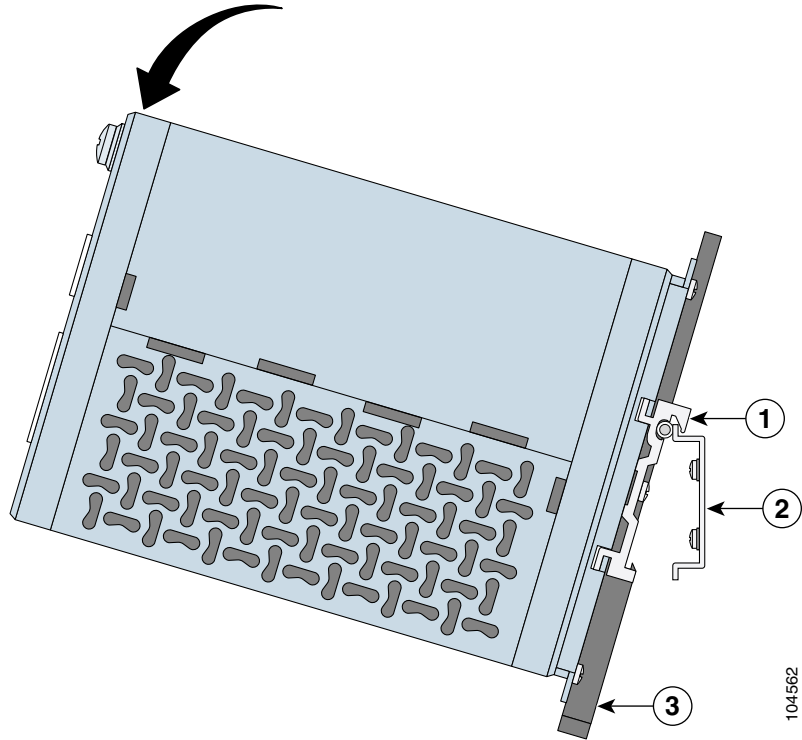

104562

<b>1</b>	DIN rail clip	<b>3</b>	DIN rail clip release tab
<b>2</b>	DIN rail		

**Figure 3-29** Mounting the Switch on a DIN Rail in a Face-Down Position

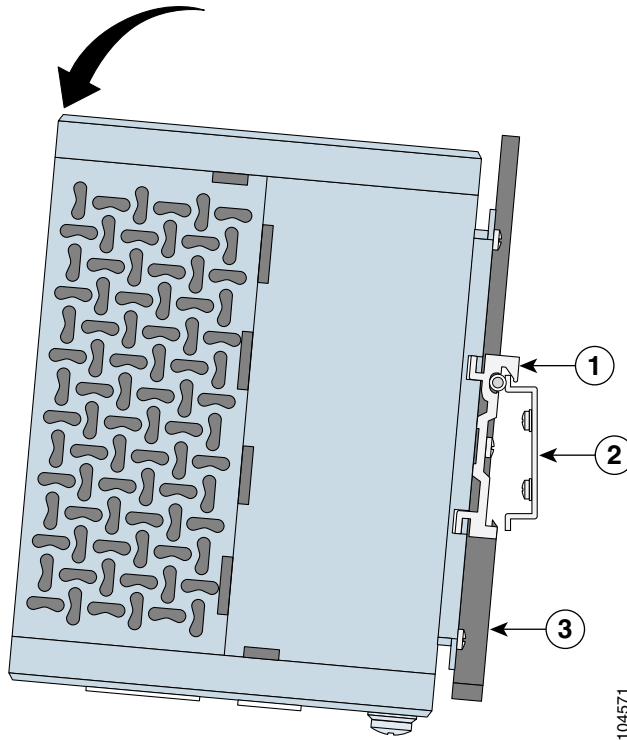

<b>1</b>	DIN rail clip	<b>3</b>	DIN rail clip release tab
<b>2</b>	DIN rail		

- Step 2** Rotate the switch down toward the DIN rail until the release tab on the rear panel clicks.
- Step 3** Lift lightly on the bottom of the switch to ensure that it is firmly locked in place.

After the switch is mounted on the DIN rail, power on the switch as described in [“Powering On the Switch and Running POST”](#) section on page 3-13.

**Note**

---

For instructions on how to remove the switch from a DIN rail, see the [“Removing the Switch from a DIN Rail or a Rack”](#) section on page 3-59.

---

## Installing the Switch in a Rack

You can use an optional DIN rail adapter kit (available through Cisco, part number STK-RACKMNT-2955=) to mount the Catalyst 2955 switch in a 19-inch rack. The rack mounting kit comes with a DIN rail adapter and screws to attach the adapter to the rack. Ask your Cisco representative for details.

**Warning**

---

**To prevent bodily injury when mounting or servicing this unit in a rack, you must take special precautions to ensure that the system remains stable. The following guidelines are provided to ensure your safety:**

- **This unit should be mounted at the bottom of the rack if it is the only unit in the rack.**
  - **When mounting this unit in a partially filled rack, load the rack from the bottom to the top with the heaviest component at the bottom of the rack.**
  - **If the rack is provided with stabilizing devices, install the stabilizers before mounting or servicing the unit in the rack.** Statement 1006
- 

**Caution**

---

To prevent the switch from overheating, there must be a minimum of 3 inches between any other device and the top, bottom, or sides of the switch.

---

To install the switch in a rack, follow these steps:

- Step 1** Use the four Phillips machine screws to securely attach the brackets to the rack, as shown in [Figure 3-30](#).

**Figure 3-30** *Installing the DIN Rail Adapter*

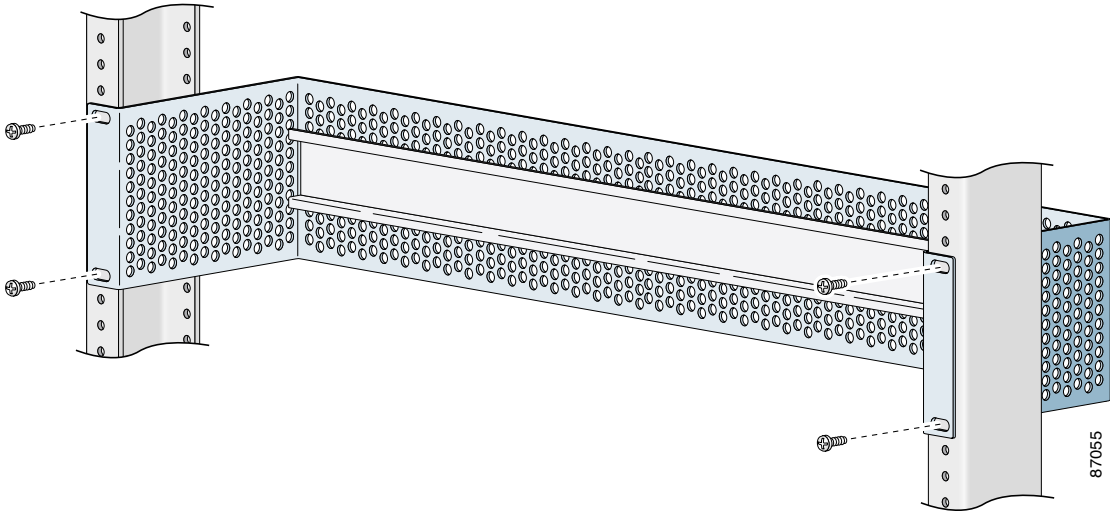

- Step 2** Position the rear panel of the switch directly in front of the DIN rail, making sure that the top of the DIN rail clip hooks over the top of the DIN rail, as shown in [Figure 3-28](#) and [Figure 3-29](#).
- Step 3** Rotate the switch down toward the DIN rail until the release tab on the rear panel clicks.
- Step 4** Lift lightly on the bottom of the switch to ensure that it is firmly locked in place. See [Figure 3-28](#) for details.

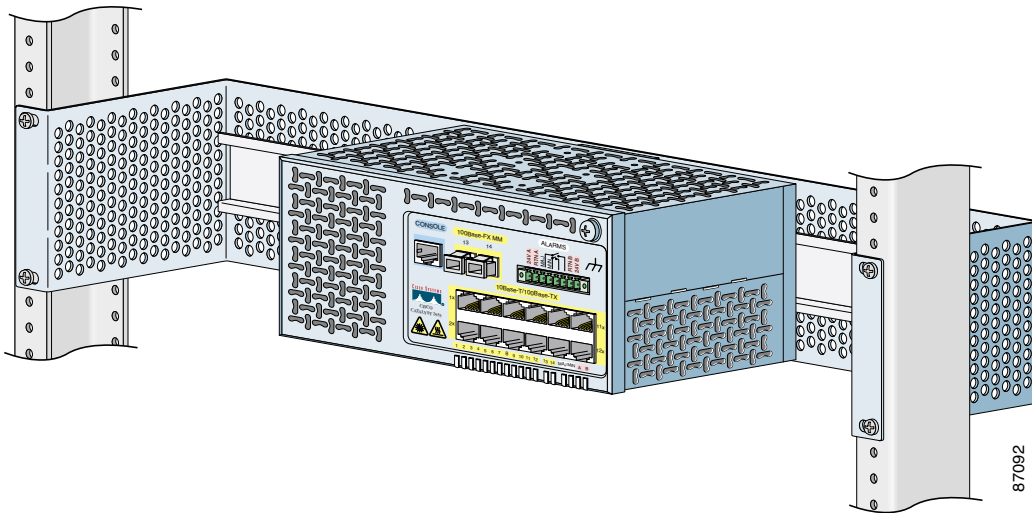

**Figure 3-31** Installing the Switch in a Rack

After mounting the switch in the rack, start the terminal-emulation software, and provide power to the switch. See the [“Powering On the Switch and Running POST”](#) section on page 3-13 for instructions.

**Note**

For instructions on how to remove the switch from a rack, see the [“Removing the Switch from a DIN Rail or a Rack”](#) section on page 3-59.

## Removing the Switch from a DIN Rail or a Rack

To remove the switch from a DIN rail or a rack, follow these steps:

- Step 1** Ensure that power is removed from the switch, and disconnect all cables and connectors from the front panel of the switch.
- Step 2** Push down on the top of the DIN rail clip release tab with your finger. As the clip releases, lift the bottom of the switch, as shown in [Figure 3-32](#) and [Figure 3-33](#).

Figure 3-32 Removing the Switch from a Parallel Mounting Position

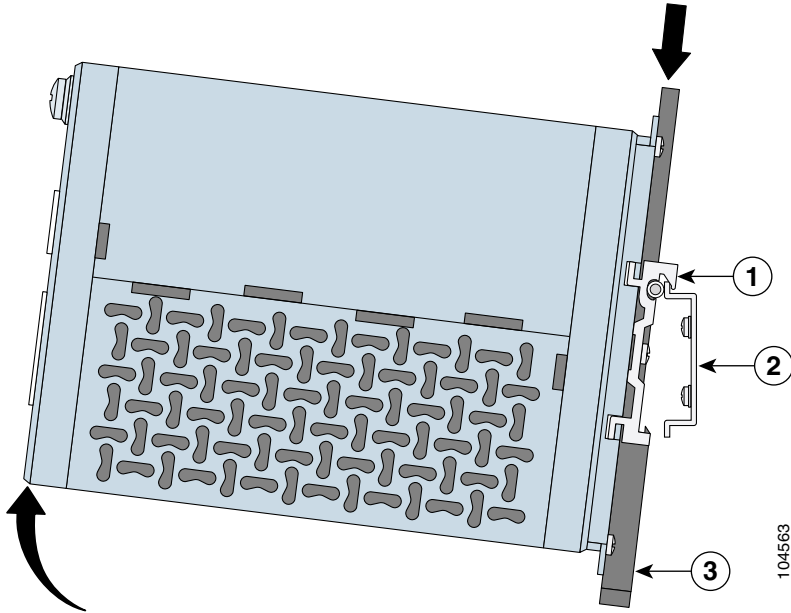

<b>1</b>	DIN rail clip	<b>3</b>	DIN rail clip release tab
<b>2</b>	DIN rail		

104563

**Figure 3-33** Removing the Switch from a Face-Down Mounting Position

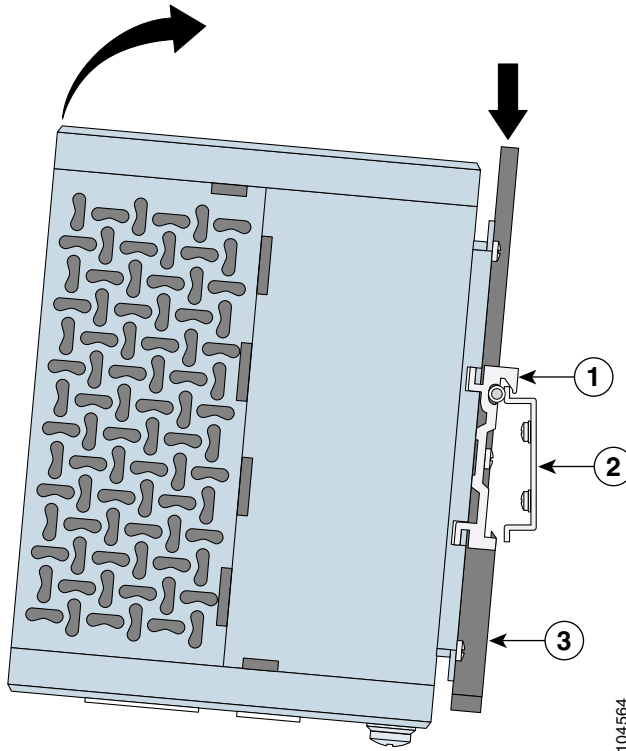

104564

<b>1</b>	DIN rail clip	<b>3</b>	DIN rail clip release tab
<b>2</b>	DIN rail		

## Connecting to 10/100 and 10/100/1000 Ports

The 10/100 ports on the Catalyst 2955 configure themselves to operate at the speed and duplex settings of attached devices. They operate at 10 or 100 Mbps in half- or full-duplex mode. If the attached devices do not support autonegotiation, you can set the speed and duplex parameters.

The 10/100/1000 ports configure themselves to operate at the speed setting of attached devices. These ports on the Catalyst 2955T-12 operate at either 10 or 100 Mbps in either full- or half-duplex mode or at 1000 Mbps in full-duplex mode. If the attached devices do not support autonegotiation, you can set the speed parameter.

Connecting devices that do not autonegotiate or devices with manually set speed and duplex parameters can reduce performance or result in link failures between the devices. To maximize performance, choose one of these methods for configuring the ports:

- Let the ports autonegotiate both speed and duplex for 10/100 ports and speed for 10/100/1000 ports.
- Set the speed and duplex parameters on both ends of the connection.



---

**Caution**

Proper ESD protection is required whenever you handle Cisco equipment. Installation and maintenance personnel should be properly grounded using ground straps to eliminate the risk of ESD damage to the switch.

Do not touch connectors or pins on component boards. Do not touch circuit components inside the switch. When not in use, store the equipment in appropriate static-safe packaging.

---

Follow these steps to connect the switch to 10BASE-T, 100BASE-TX, or 1000BASE-T devices:

- Step 1** When connecting to servers, workstations, and routers, insert a twisted-pair straight-through cable in a front-panel RJ-45 connector, as shown in [Figure 3-34](#) and [Figure 3-35](#). When connecting to switches or repeaters, insert a twisted-pair crossover cable. (See the “[Cable and Adapter Specifications](#)” section on [page B-5](#) for cable-pinout descriptions.)



**Note** When connecting to 1000BASE-T devices, be sure to use a four twisted-pair, Category 5 cable.

**Figure 3-34** Connecting to a 10/100 Port on the Catalyst 2955 Switch

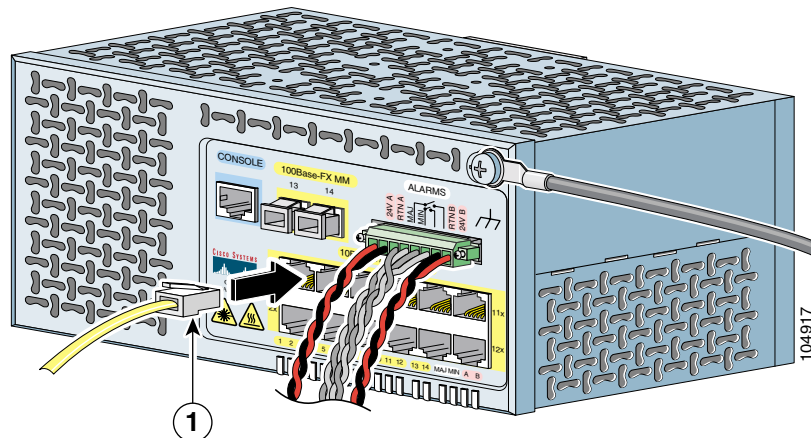

**1** Ethernet cable



# Connecting to 100BASE-FX MM Ports

**Warning**

**Class 1 LED product.** Statement 1027

The 100BASE-FX MM fiber-optic uplink ports operate in full-duplex mode.

You can connect a 100BASE-FX port to a port on a target device by using one of the MT-RJ fiber-optic patch cables listed in [Table B-1 on page B-3](#). Use the Cisco part numbers in [Table B-1](#) to order the patch cables that you need.

**Caution**

Do not remove the dust plugs from the fiber-optic ports or the rubber caps from the MT-RJ patch cable. The plugs and caps protect the fiber-optic ports and cables from contamination and ambient light.

Follow these steps to connect the switch to a MM 100BASE-FX device:

- Step 1** Remove the dust plugs from the 100BASE-FX port, as shown in [Figure 3-36](#), and store them for future use. Remove the rubber caps from the MT-RJ patch cable. Store them for future use.

**Figure 3-36** Removing Dust Plugs from 100BASE-FX Ports

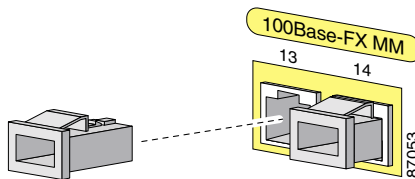





# Connecting to 100BASE-LX SM Ports

**Warning**

**Invisible laser radiation may be emitted from disconnected fibers or connectors. Do not stare into beams or view directly with optical instruments.**  
Statement 1051

**Warning**

**Avoid direct exposure to the laser beam.** Statement 1012

You can connect a 100BASE-LX port to a port on a target device by using one of the LC fiber-optic patch cables listed in [Table B-2 on page B-4](#). Use the Cisco part numbers in [Table B-2](#) to order the patch cables that you need.

Follow these steps to connect the switch to a 100BASE-LX SM device:

**Caution**

Do not remove the dust plugs from the fiber-optic ports or the rubber caps from the fiber-optic cable until you are ready to connect the cable. The plugs and caps protect the fiber-optic ports and cables from contamination and ambient light.

**Step 1**

Remove the dust plugs from the 100BASE-LX port, as shown in [Figure 3-38](#), and store them for future use. Remove the rubber caps from the LC on the fiber-optic cable. Store them for future use.

**Figure 3-38**      **Removing Dust Plugs from 100BASE-LX Ports**

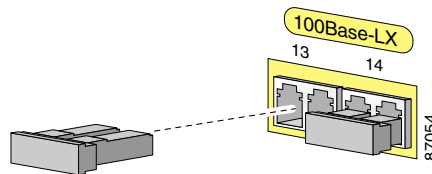

**Step 2** Insert the cable in a 100BASE-LX port. (See [Figure 3-39](#).)

**Figure 3-39** Connecting to a 100BASE-LX SM Port

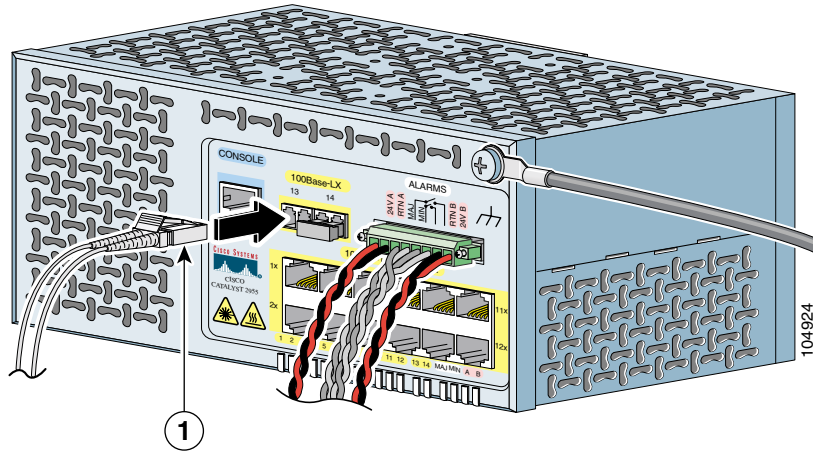

<b>1</b>	Fiber-optic uplink cable
----------	--------------------------

**Step 3** Insert the other cable end in an LC port on the target device.

**Step 4** Observe the port status LED.

The LED turns green when the switch and the target device have an established link.

The LED turns amber while STP discovers the network topology and searches for loops. This process can take about 30 seconds, and then the port LED turns green.

If the LED is off, the target device might not be turned on, there might be a cable problem, or there might be a problem with the adapter installed in the target device. See [Chapter 5, “Troubleshooting,”](#) for solutions to cabling problems.

**Step 5** Reconfigure and restart the target device, if necessary.

**Step 6** Repeat Steps 1 through 5 to connect each port.

## Where to Go Next

If the default configuration is satisfactory, the switch does not need further configuration. You can use any of these management options to change the default configuration:

- Start the device manager, which is in the switch memory, to manage individual and standalone switches. The device manager is an easy-to-use web interface that offers quick configuration and monitoring. You can access the device manager from anywhere in your network through a web browser. For more information, see the device manager online help.
- Start the Network Assistant application, which is described in the *Getting Started with Cisco Network Assistant* guide on Cisco.com. Through this GUI, you can configure and monitor a switch cluster or an individual switch.
- Use the CLI from the console to configure the switch as a member of a cluster or as an individual switch. See the *Catalyst 2950 and Catalyst 2955 Switch Software Configuration Guide* and the *Catalyst 2950 and Catalyst 2955 Switch Command Reference* on Cisco.com for information on using the CLI with a Catalyst 2955 switch.
- Start an SNMP application such as the CiscoView application.





# Installation in a Hazardous Environment

---

This chapter describes how to install your switch in a hazardous environment, to interpret the power-on self-test (POST), and to connect the switch to other devices. Read these topics, and perform the procedures in this order:

- [Preparing for Installation, page 4-2](#)
- [Applying the Switch Protective Liner, page 4-13](#)
- [Verifying Switch Operation, page 4-14](#)
- [Wiring the External Alarm Device Relays, page 4-32](#)
- [Installing the Switch on a DIN Rail, page 4-37](#)
- [Installing the Switch in a Rack, page 4-42](#)
- [Removing the Switch from a DIN Rail or a Rack, page 4-45](#)
- [Connecting to 10/100 and 10/100/1000 Ports, page 4-47](#)
- [Connecting to 100BASE-FX MM Ports, page 4-50](#)
- [Connecting to 100BASE-LX SM Ports, page 4-52](#)
- [Where to Go Next, page 4-54](#)

# Preparing for Installation

This section provides information about these topics:

- [Warnings, page 4-2](#)
- [EMC Regulatory Statements, page 4-8](#)
- [Installation Guidelines, page 4-11](#)
- [Verifying Package Contents, page 4-12](#)

## Warnings

These warnings are translated into several languages in [Appendix C, “Translated Safety Warnings.”](#)



**Warning**

---

**This equipment is to be installed and maintained by service personnel only as defined by AS/NZS 3260 Clause 1.2.14.3 Service Personnel.** Statement 88

---



**Warning**

---

**Only trained and qualified personnel should be allowed to install or replace this equipment.** Statement 49

---



**Warning**

---

**This unit is intended for installation in restricted access areas. A restricted access area can be accessed only through the use of a special tool, lock and key, or other means of security.** Statement 1017

---



**Warning**

---

**Read the installation instructions before you connect the system to its power source.** Statement 1004

---



**Warning**

---

**Do not stack the chassis on any other equipment. If the chassis falls, it can cause severe bodily injury and equipment damage.** Statement 48

---

**Warning**

---

**Do not disconnect connections to this equipment unless power has been removed or you have verified that the area is nonhazardous. Secure any external connections that mate to this equipment by using screws, sliding latches, threaded connectors, or other means provided with this product.**

**Substitution of components may impair suitability for Class I, Division 2.**

Statement 1062

---

**Warning**

---

**When you connect or disconnect the power and relay connector with power applied, an electrical arc can occur. This could cause an explosion in hazardous area installations. Be sure that power is removed from the switch and alarm circuit. Be sure that power cannot be accidentally turned on or verify that the area is nonhazardous before proceeding.**

**Failure to securely tighten the power and relay connector captive screws can result in an electrical arc if the connector is accidentally removed.** Statement 1058

---

**Warning**

---

**Connect the unit only to DC power source that complies with the safety extra-low voltage (SELV) requirements in IEC 60950 based safety standards.**

Statement 1033

---

**Warning**

---

**The nominal voltage for this product is 24 V. When the switch is installed in hazardous locations, the safe operating range of 18 to 30 VDC must be maintained.** Statement 1060

---

**Warning**

---

The switch relays are rated at 1 Amp and have a voltage limit of 30 VDC and 0.3 Amp at a voltage limit of 125 VAC. It is dangerous to exceed these limitations in a hazardous environment.

An electrical arc can occur when you connect or disconnect the relay wires with field side power applied. This could cause an explosion in switch installations in a hazardous location. Before proceeding, be sure that power is removed or the area is not hazardous. Statement 1061.

---

**Warning**

---

This equipment is intended for use in a Pollution Degree 2 industrial environment, in overvoltage Category II applications (as defined in IEC publication 60664-1), and at altitudes up to 2000 meters without derating. Statement 1068

---

**Warning**

---

This equipment is supplied as “open type” equipment. It must be mounted within an enclosure that is suitably designed for those specific environmental conditions that will be present and appropriately designed to prevent personal injury resulting from accessibility to live parts. The interior of the enclosure must be accessible only by the use of a tool.

The enclosure must meet IP 54 or NEMA type 4 minimum enclosure rating standards. Statement 1063

---

**Warning**

---

Use twisted-pair supply wires suitable for 86°F (30°C) above surrounding ambient temperature outside the enclosure. Statement 1067

---

**Warning**

---

An exposed wire lead from a DC-input power source can conduct harmful levels of electricity. Be sure that no exposed portion of the DC-input power source wire extends from the power and relay connector. Statement 122

---



**Warning**

**In switch installations in a hazardous location, the DC power source could be located away from the vicinity of the switch. Be sure that power is removed and power cannot be accidentally be turned on or the area is nonhazardous before proceeding.** Statement 1059

**Warning**

**If you connect or disconnect the console cable with power applied to the switch or any device on the network, an electrical arc can occur. This could cause an explosion in hazardous location installations. Be sure that power is removed or the area is nonhazardous before proceeding.**

**To verify switch operation, perform POST on the switch in a nonhazardous location before installation.** Statement 1065

**Warning**

**Do not connect or disconnect cables to the ports while power is applied to the switch or any device on the network because an electrical arc can occur. This could cause an explosion in hazardous location installations. Be sure that power is removed from the switch and cannot be accidentally be turned on, or verify that the area is nonhazardous before proceeding.** Statement 1070

**Warning**

**To prevent the switch from overheating, do not operate it in an area that exceeds the maximum recommended ambient temperature of 140°F (60°C). To prevent airflow restriction, allow at least 3 inches (7.6 cm) of clearance around the ventilation openings.** Statement 17C

**Warning**

**When used in a Class I, Division 2, hazardous location, this equipment must be mounted in a suitable enclosure with proper wiring method, for all power, input and output wiring, that complies with the governing electrical codes and in accordance with the authority having jurisdiction over Class I, Division 2 installations.** Statement 1066

**Warning**

**When installing the unit, always make the ground connection first and disconnect it last.** Statement 42

**Warning**

---

**This equipment is intended to be grounded. Ensure that the host is connected to earth ground during normal use.** Statement 39

---

**Warning**

---

**This equipment is intended to be grounded to comply with emission and immunity requirements. Ensure that the switch functional ground lug is connected to earth ground during normal use.** Statement 1064

---

**Warning**

---

**Before working on equipment that is connected to power lines, remove jewelry (including rings, necklaces, and watches). Metal objects will heat up when connected to power and ground and can cause serious burns or weld the metal object to the terminals.** Statement 43

---

**Warning**

---

**To prevent bodily injury when mounting or servicing this unit in a rack, you must take special precautions to ensure that the system remains stable. The following guidelines are provided to ensure your safety:**

- **This unit should be mounted at the bottom of the rack if it is the only unit in the rack.**
  - **When mounting this unit in a partially filled rack, load the rack from the bottom to the top with the heaviest component at the bottom of the rack.**
  - **If the rack is provided with stabilizing devices, install the stabilizers before mounting or servicing the unit in the rack.** Statement 1006
- 

**Warning**

---

**Before performing any of the following procedures, ensure that power is removed from the DC circuit. To ensure that all power is OFF, locate the circuit breaker on the panel board that services the DC circuit, switch the circuit breaker to the OFF position, and tape the switch handle of the circuit breaker in the OFF position.** Statement 140

---

**Warning**

**Do not work on the system or connect or disconnect cables during periods of lightning activity.** Statement 1001

**Warning**

**Ultimate disposal of this product should be handled according to all national laws and regulations.** Statement 180

**Warning**

**Class 1 laser product.** Statement 1008

**Warning**

**Class 1 LED product.** Statement 1027

**Warning**

**Invisible laser radiation may be emitted from disconnected fibers or connectors. Do not stare into beams or view directly with optical instruments.** Statement 1051

**Warning**

**For diverging beams, viewing the laser output with certain optical instruments within a distance of 100 mm may harm your eyes. For collimated beams, viewing the laser output with certain optical instruments designed for use at a distance may harm your eyes.** Statement 282

**Warning**

**Avoid direct exposure to the laser beam.** Statement 1012

**Caution**

This equipment is suitable for use in Class I, Division 2, Groups A, B, C, D, or non-hazardous locations only.

## EMC Regulatory Statements

This section includes specific regulatory statements about the Catalyst 2955 family of switches.

### U.S.A.

U.S. regulatory information for this product is in the front matter of this manual.

### Class A Notice for Taiwan and Other Traditional Chinese Markets



#### Warning

---

**This is a Class A Information Product, when used in residential environment, it may cause radio frequency interference, under such circumstances, the user may be requested to take appropriate countermeasures.** Statement 257

#### 警告

這是甲類資訊產品，在居住環境中使用時，可能會造成射頻干擾，在這種情況下，使用者會被要求採取某些適當的對策。

---

## VCCI Class A Notice for Japan



### Warning

**This is a Class A product based on the standard of the Voluntary Control Council for Interference by Information Technology Equipment (VCCI). If this equipment is used in a domestic environment, radio disturbance may arise. When such trouble occurs, the user may be required to take corrective actions.** Statement 191

### 警告

これは、情報処理装置等電波障害自主規制協議会（VCCI）の規定に基づくクラスA装置です。この装置を家庭環境で使用すると、電波妨害を引き起こすことがあります。この場合には、使用者が適切な対策を取るよう要求されることがあります。

## Class A Warning for Korea



### Warning

**This is a Class A Device and is registered for EMC requirements for industrial use. The seller or buyer should be aware of this. If this type was sold or purchased by mistake, it should be replaced with a residential-use type.** Statement 294

### 주의

A급 기기 이 기기는 업무용으로 전자파 적합 등록을 한 기기이오니 판매자 또는 사용자는 이 점을 주의하시기 바라며 만약 잘못 판매 또는 구입하였을 때에는 가정용으로 교환하시기 바랍니다.

## Class A Warning for Hungary



### Warning

**This equipment is a class A product and should be used and installed properly according to the Hungarian EMC Class A requirements (MSZEN55022). Class A equipment is designed for typical commercial establishments for which special conditions of installation and protection distance are used.** Statement

256

### Figyelem

**Figyelmeztetés a felhasználói kézikönyv számára: Ez a berendezés "A" osztályú termék, felhasználására és üzembe helyezésére a magyar EMC "A" osztályú követelményeknek (MSZ EN 55022) megfelelően kerülhet sor, illetve ezen "A" osztályú berendezések csak megfelelő kereskedelmi forrásból származhatnak, amelyek biztosítják a megfelelő speciális üzembe helyezési körülményeket és biztonságos üzemelési távolságok alkalmazását.**

## European Zone 2 Certification

This equipment is intended for use in potentially explosive atmospheres as defined by European Union Directive 94/9/EC. Underwriters Laboratory International DEMKO certifies that this equipment has been found to comply with the Essential Health and Safety Requirements relating to the design and construction of Category 3 equipment intended for use in potentially explosive atmospheres, given in Annex II to this Directive. Compliance with the Essential Health and Safety Requirements has been assured by compliance with EN 50021 (1999).

## Installation Guidelines

When determining where to place the switch, observe these guidelines.

- Before installing the switch, first verify that the switch is operational by powering it on and running POST. Follow the procedures in the [“Powering On the Switch and Running POST”](#) section on page 4-16.
- For 10/100 ports and 10/100/1000 ports, the cable length from a switch to an attached device cannot exceed 328 feet (100 meters).
- For 100BASE-FX multimode fiber-optic (MM) ports, the cable length from a switch to an attached device cannot exceed 6562 feet (2 kilometers).
- For 100BASE-LX single-mode fiber-optic (SM) ports, the cable length from a switch to an attached device cannot exceed 9.375 miles (15 kilometers).
- Operating environment is within the ranges listed in [Appendix A, “Technical Specifications.”](#)
- Clearance to front and rear panels meet these conditions:
  - Front-panel LEDs can be easily read.
  - Access to ports is sufficient for unrestricted cabling.
  - Front-panel direct current (DC) power and relay connector is within reach of the connection to the DC circuit breaker.
- Airflow around the switch and through the vents is unrestricted. To prevent the switch from overheating, there must be a minimum of 3 inches between any other device and the top, bottom, or sides of the switch.
- Temperature surrounding the unit does not exceed 140°F (60°C).



---

**Note** When the switch is installed in an industrial enclosure, the temperature within the enclosure is greater than normal room temperature outside the enclosure.

The temperature inside the enclosure cannot exceed 140°F (60°C), the maximum ambient enclosure temperature of the switch.

---

- Cabling is away from sources of electrical noise, such as radios, power lines, and fluorescent lighting fixtures.

## Verifying Package Contents

**Note**

---

Carefully remove the contents from the shipping container, and check each item for damage. If any item is missing or damaged, contact your Cisco representative or reseller for support. Return all packing materials to the shipping container and save them.

---

The switch is shipped with these items:

- *Catalyst 2955 Hardware Installation Guide* (Cisco part number DOC-7814944=)
- Power and relay connector
- Switch installation protective liner
- One ferrite
- One RJ-45-to-DB-9 console port adapter cable

**Note**

---

To connect the switch functional ground, you need a ring terminal lug (such as Thomas & Bett part number RC10-14 or equivalent).

---

If you want to connect a terminal to the switch console port, you need to provide an RJ-45-to-DB-25 female DTE adapter. You can order a kit (part number ACS-DSBUASYN=) with that adapter from Cisco.



For multimode (MM) connections, you can connect a 100BASE-FX port to a port on a target device by using one of the MT-RJ fiber-optic patch cables listed in [Table B-1 on page B-3](#). Use the Cisco part numbers in [Table B-1](#) to order the patch cables that you need.

For single-mode (SM) connections, you can connect a 100BASE-LX port to a port on a target device by using one of the connectors listed in [Table B-2 on page B-4](#). Use the Cisco part numbers in [Table B-2](#) to order the patch cables that you need.

## Applying the Switch Protective Liner

The switch ships with a protective liner that prevents debris from falling into the switch ventilation holes during installation. Before installing the switch on a DIN rail or in a 19-inch rack, connecting the switch to a power source, or wiring the external alarm device relays, you must first apply the protective liner.

Because the protective liner covers ventilation holes on the switch, the liner must be removed from the switch before power is applied to allow proper airflow through the switch chassis.

Follow these steps to apply the protective liner:

- 
- Step 1** Peel the protective liner from the backing.
- Step 2** Apply the protective liner to the switch:
- If you are installing the switch in a parallel mounting position, apply the protective liner to the switch top panel.
  - If you are installing the switch in a face-down mounting position, apply the protective liner to the switch rear panel.
-

**Caution**

Remove the protective liner before applying power to the switch.

Failure to remove the protective liner could result in thermal damage to the switch.

## Verifying Switch Operation

**Warning**

**If you connect or disconnect the console cable with power applied to the switch or any device on the network, an electrical arc can occur. This could cause an explosion in hazardous location installations. Be sure that power is removed or the area is nonhazardous before proceeding.**

**To verify switch operation, perform POST on the switch in a nonhazardous location before installation.** Statement 1065

Before installing the switch on a DIN rail or in a 19-inch rack, you should power on the switch and verify that the switch passes power-on self-test (POST). These sections describe the steps required to connect a PC to the switch console port, to power on the switch, and to observe POST:

[Connecting a PC or a Terminal to the Console Port, page 4-14](#)

[Powering On the Switch and Running POST, page 4-16](#)

## Connecting a PC or a Terminal to the Console Port

To connect a PC to the console port, use the supplied RJ-45-to-DB-9 adapter cable. To connect a terminal to the console port, you need to provide an RJ-45-to-DB-25 female DTE adapter. You can order a kit (part number ACS-DSBUASYN=) with that adapter from Cisco. For console-port and adapter-pinout information, see the [“Cable and Adapter Specifications” section on page B-5](#).

The PC or terminal must support VT100 terminal emulation. The terminal-emulation software—frequently a PC application such as HyperTerminal or Procomm Plus—makes communication between the switch and your PC or terminal possible during the setup program.

Follow these steps to connect the PC or terminal to the switch:

- 
- Step 1** Make sure that your terminal-emulation software is configured to communicate with the switch through hardware flow control.
- Step 2** Configure the baud rate and data format of the PC or terminal to match these console-port default characteristics:
- 9600 baud
  - Eight data bits
  - One stop bit
  - No parity

After gaining access to the switch, you can change the port baud rate. See the switch software configuration guide for instructions.

- Step 3** Insert the adapter cable in the console port, as shown in [Figure 4-1](#). (See the “[Cable and Adapter Pinouts](#)” section on [page B-9](#) for pinout descriptions.)

Figure 4-1 Connecting to the Console Port

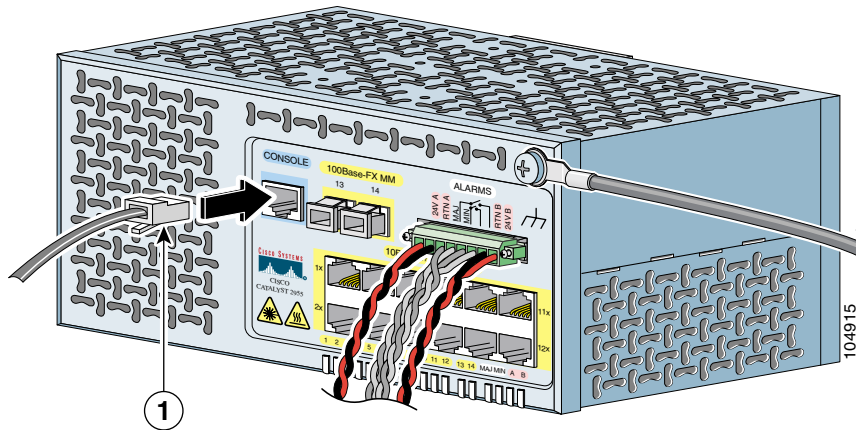

1	Console cable
---	---------------

- Step 4** Attach the appropriate adapter to the terminal, if needed.
- Step 5** Insert the other adapter cable end in the PC or terminal adapter.
- Step 6** Start the terminal-emulation software.

## Powering On the Switch and Running POST



### Warning

If you connect or disconnect the console cable with power applied to the switch or any device on the network, an electrical arc can occur. This could cause an explosion in hazardous location installations. Be sure that power is removed or the area is nonhazardous before proceeding.

To verify switch operation, perform POST on the switch in a nonhazardous location before installation. Statement 1065

**Caution**

---

The AC/DC power converter (PWR-2955-AC=) can only be used in a nonhazardous location installation.

---

These sections describe the steps required to power on the switch and to observe POST:

[Grounding the Switch, page 4-18](#)

[Wiring the DC Power Source, page 4-21](#)

[Add the Ferrite to the Power and Relay Connector Wiring, page 4-27](#)

[Attach the Power and Relay Connector to the Switch, page 4-28](#)

[Power On the Switch, page 4-30](#)

[Running POST, page 4-30](#)

Locate the power and relay connector, the ferrite, and the switch installation protective liner in the switch kit.

**Note**

---

You can get replacement power and relay connectors (PWR-2955-CONNECT=) by calling Cisco Technical Support. See the [“Obtaining Technical Assistance” section on page xxviii](#).

---

Obtain these necessary tools and equipment:

- Ratcheting torque flathead screwdriver that exerts up to 15 inch pounds (in-lbs.) of pressure
- Ring terminal lug (such as Thomas & Bett part number RC10-14 or equivalent)
- Crimping tool (such as Thomas & Bett part number WT2000 , ERG-2001, or equivalent)
- 10- to 12-gauge copper ground wire (such as Belden part number 9912 or equivalent)

- Four leads of 18-gauge copper wire, UL and CSA rated, style 1007 or 1569 twisted-pair copper appliance wiring material (AWM) wire (such as Belden part number 9318)
- Wire-stripping tools for stripping 10-to-12- and 18-gauge wires

## Grounding the Switch



### Warning

**This equipment is intended to be grounded to comply with emission and immunity requirements. Ensure that the switch functional ground lug is connected to earth ground during normal use.** Statement 1064



### Warning

**When installing the unit, always make the ground connection first and disconnect it last.** Statement 42



### Caution

To make sure that the equipment is reliably connected to earth ground, follow the grounding procedure instructions, and use a UL-listed ring terminal lug suitable for number-10 to 12 AWG wire, such as Thomas & Bett part number RC10-14 or equivalent.

To ground the switch to earth ground by using the functional ground screw, follow these steps. Make sure to follow any grounding requirements at your site.

- Step 1** Use a standard Phillips screwdriver or a ratcheting torque screwdriver with a Phillips head to remove the ground screw from the front panel of the switch. Store the ground screw for later use.
- Step 2** If your ground wire is insulated, use a wire stripping tool to strip the 10- to 12-gauge ground wire to 0.5 inch (12.7 millimeter [mm])  $\pm$  0.02 inch (0.5 mm) as shown in [Figure 4-2](#).

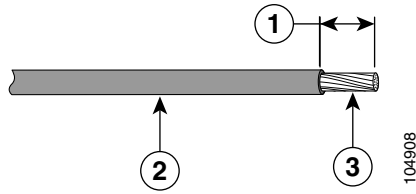
**Figure 4-2** Stripping the Ground Wire

<b>1</b>	0.5 inch (12.7 mm) ± 0.02 inch (0.5 mm)	<b>3</b>	Wire lead
<b>2</b>	Insulation		

- Step 3** Insert the ground wire into the ring terminal lug, and using a crimping tool, crimp the ring terminal to the wire.

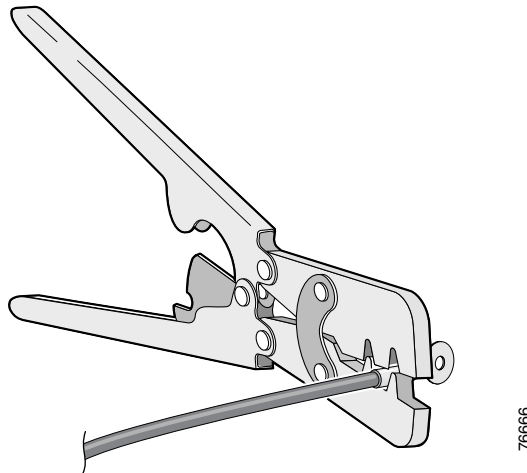
**Figure 4-3** Crimping the Ring Terminal

- Step 4** Slide the ground screw through the ring terminal.
- Step 5** Insert the ground screw into the functional ground screw opening on the front panel.

- Step 6** Using a ratcheting torque screwdriver, tighten the ground screw and ring terminal lug to the switch front panel to 15 in.-lbs. (240 ounce-force inches [ozf-in.]), as shown in [Figure 4-4](#).

**Figure 4-4** Torquing Ground-Lug Screws

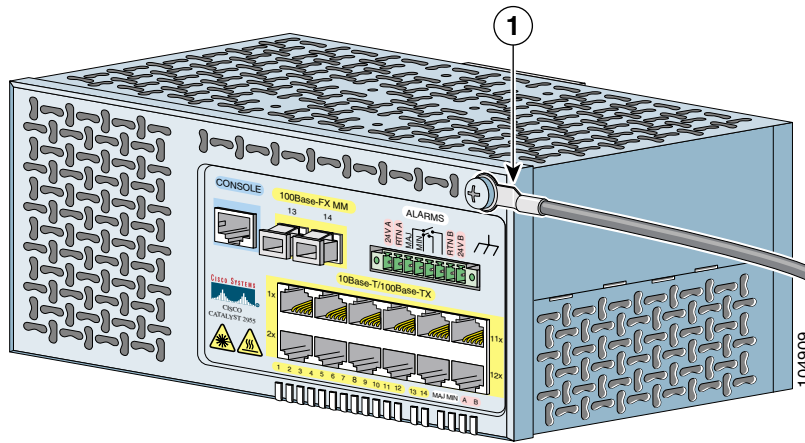

<b>1</b>	Grounding cable
----------	-----------------

- Step 7** Attach the other end of the ground wire to a grounded bare metal surface, such as a ground bus, a grounded DIN rail, or a grounded bare rack.



## Wiring the DC Power Source



Warning

---

**Only trained and qualified personnel should be allowed to install or replace this equipment.** Statement 49

---



Warning

---

**In switch installations in a hazardous location, the DC power source could be located away from the vicinity of the switch. Be sure that power is removed and power cannot be accidentally be turned on or the area is nonhazardous before proceeding.** Statement 1059

---



Warning

---

**When you disconnect the power and relay connector with power applied to the switch, an electrical arc can occur. This could cause an explosion in hazardous area installations. Be sure that power is removed from the switch and cannot be accidentally be turned on, or verify that the area is nonhazardous before proceeding.**

**Failure to securely tighten the power and relay connector captive screws can result in an electrical arc if the connector is accidentally removed.** Statement 1058

---



Warning

---

**Connect the unit only to DC power source that complies with the safety extra-low voltage (SELV) requirements in IEC 60950 based safety standards.**

Statement 1033

---



Caution

---

The AC/DC power converter (PWR-2955-AC=) can only be used in a nonhazardous location installation.

---



Caution

---

You must connect the Catalyst 2955 switch only to a DC-input power source that has an input supply voltage from 18 to 32 VDC. If the supply voltage is not in this range, the switch might not operate properly or might be damaged.

---

**Caution**

The switch must be installed with 2 A-branch-circuit protection.

**Caution**

This installation must comply with all applicable codes.

**Note**

For wire connections to the power and relay connector, you must use UL and CSA rated, style 1007 or 1569 twisted-pair copper appliance wiring material (AWM) wire (such as Belden part number 9318).

You must also use the ferrite that ships with the switch.

To wire the switch to a DC-input power source, follow these steps:

- Step 1** Locate the power and relay connector (see [Figure 4-5](#)).

**Figure 4-5** Power and Relay Connector

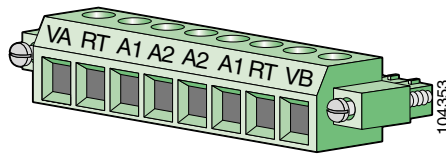

- Step 2** Identify the positive and return feed positions for the power and relay connector. The positive DC power connection from power supply A is labeled VA, and the return is the adjacent connection labeled RT. The positive DC power connection from power supply B (the redundant power supply) is labeled VB, and the return is the adjacent connection labeled RT.
- Step 3** Measure two strands of twisted-pair copper wire (18 to 20 AWG) long enough to connect to the DC power source.
- Step 4** Using an 18-gauge wire-stripping tool, strip each of the two wires coming from each DC-input power source to 0.25 inch (6.3 mm)  $\pm$  0.02 inch (0.5 mm). Do not strip more than 0.27 inch (6.8 mm) of insulation from the wire. Stripping more than the recommended amount of wire can leave exposed wire from the power and relay connector after installation.

**Figure 4-6** Stripping the Power Connection Wire

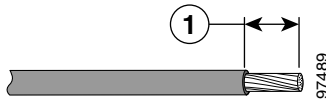

---

<b>1</b>	0.25 in. (6.3 mm) ± 0.02 in. (0.5 mm)
----------	---------------------------------------

---

- Step 5** Insert the exposed DC-input power source wires into the power and relay connector, as shown in [Figure 4-7](#). Make sure that you cannot see any wire lead. Only wire *with insulation* should extend from the connector.



**Warning**

---

**An exposed wire lead from a DC-input power source can conduct harmful levels of electricity. Be sure that no exposed portion of the DC-input power source wire extends from the power and relay connector.** Statement 122

---

**Figure 4-7** Inserting Wires in the Power and Relay Connector

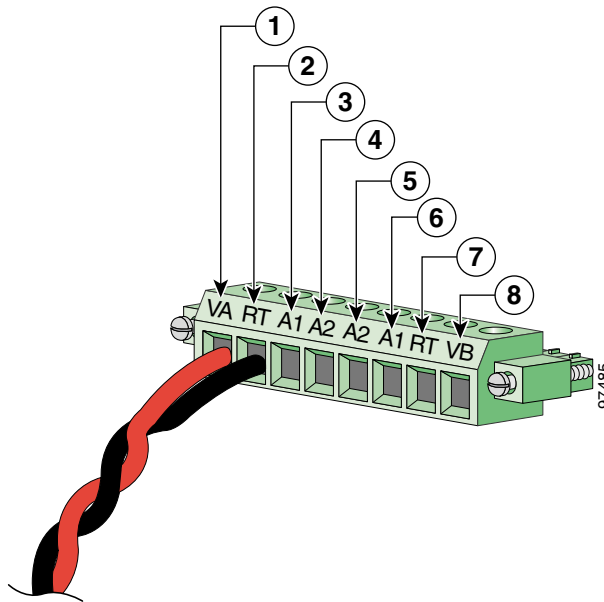

<b>1</b>	Power supply A positive connection	<b>5</b>	External device 2, relay wire B connection
<b>2</b>	Power supply A return connection	<b>6</b>	External device 1, relay wire B connection
<b>3</b>	External device 1, relay wire A connection	<b>7</b>	Power supply B return connection
<b>4</b>	External device 2, relay wire A connection	<b>8</b>	Power supply B positive connection

**Step 6** Use a ratcheting torque flathead screwdriver to torque the power and relay connector captive screws (above the installed wire leads) to 4.5 in-lbs. (72 ozf-in.). (See [Figure 4-8](#).)



**Caution**

Do not overtorque the power and relay connector captive screws. The recommended maximum torque is 4.5 in-lbs.

**Figure 4-8** Torquing the Power and Relay Connector Captive Screws

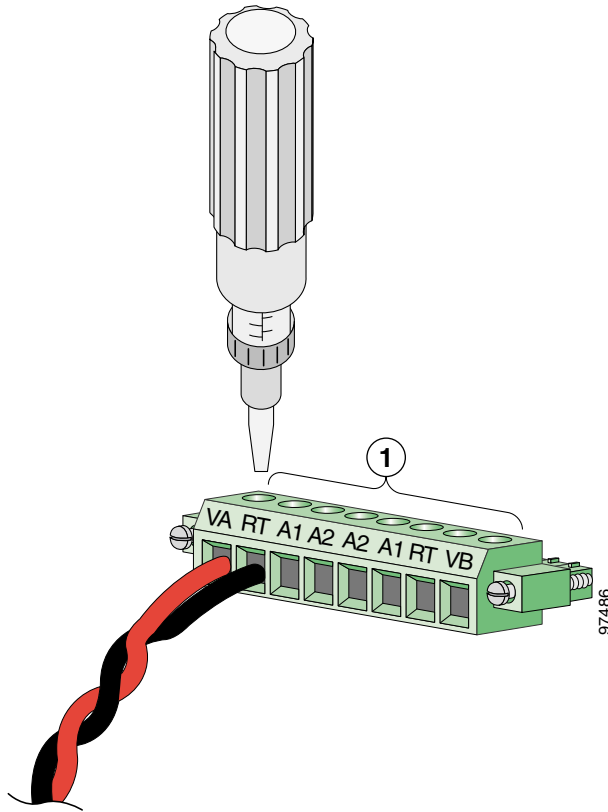

---

**1** Power and relay connector captive screws

---

**Step 7** Connect the other end of the wire connected to VA to the positive pole on the DC power source, and connect the other end of the wire connected to RT to the return pole on the DC power source.



**Note** If you are connecting a second power supply, repeat [Step 4](#) through [Step 7](#) for the DC-input (VB) and return (RT) for power supply B.

---

Figure 4-9 shows the completed DC-input wiring on a power and relay connector for a primary power supply and an optional secondary power supply.

**Figure 4-9** Completed DC Power Connections on the Power and Relay Connector

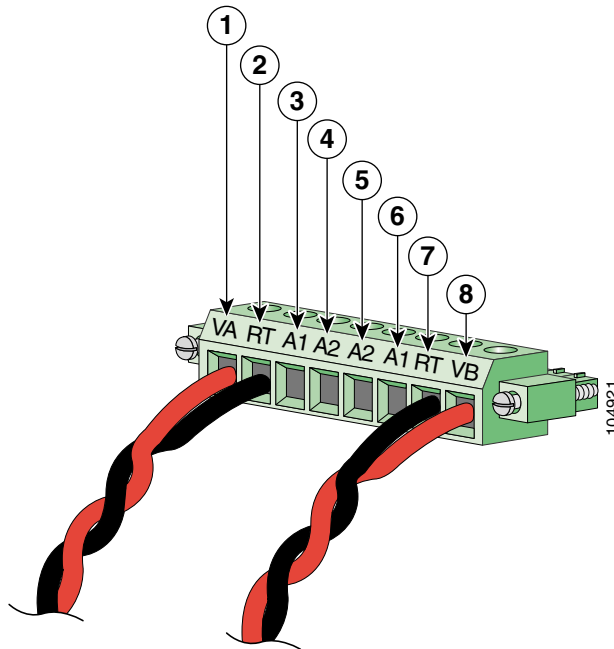

1	Power supply A positive connection	5	External device 2, relay wire B connection
2	Power supply A return connection	6	External device 1, relay wire B connection
3	External device 1, relay wire A connection	7	Power supply B return connection
4	External device 2, relay wire A connection	8	Power supply B positive connection

**Note**

If you plan to connect external alarm devices to the alarm relays, go to the [“Wiring the External Alarm Device Relays”](#) section on page 4-32. Otherwise, go to the next sections.

## Add the Ferrite to the Power and Relay Connector Wiring

Before you connect the power and relay connector to the front panel, follow these steps to add a ferrite to the power and relay connector wiring.

- Step 1** Position the opened ferrite around the wiring within 3 inches of the power and relay connector.
- Step 2** Loop the wiring around the ferrite (see [Figure 4-10](#)).

**Figure 4-10** Wire Looped Through the Ferrite

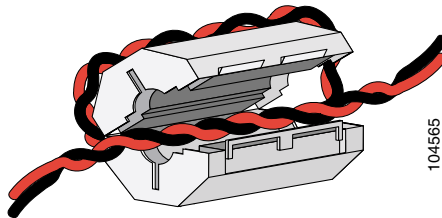

- Step 3** Press the ferrite closed until the clasp snaps shut (see [Figure 4-11](#)).

**Figure 4-11**      *Clasping the Ferrite*

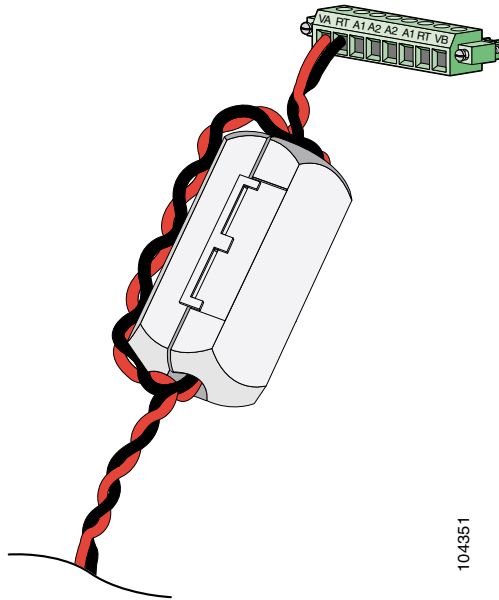

## Attach the Power and Relay Connector to the Switch

Follow these steps to attach the power and relay connector to the front panel of the switch.



### Warning

**When you connect or disconnect the power and relay connector with power applied, an electrical arc can occur. This could cause an explosion in hazardous area installations. Be sure that power is removed from the switch and alarm circuit. Be sure that power cannot be accidentally turned on or verify that the area is nonhazardous before proceeding.**

**Failure to securely tighten the power and relay connector captive screws can result in an electrical arc if the connector is accidentally removed.** Statement 1058



- Step 1** Insert the power and relay connector into the power and relay connector receptacle on the switch front panel (see [Figure 4-11](#)).
- Step 2** Use a flathead screwdriver to tighten the captive screws on the sides of the power and relay connector.

**Caution**

Secure the wires coming from the power and relay connector so that they cannot be disturbed by casual contact. For example, use tie wraps to secure the wires to the rack.

**Figure 4-12** Connecting the Power and Relay Connector to the Switch

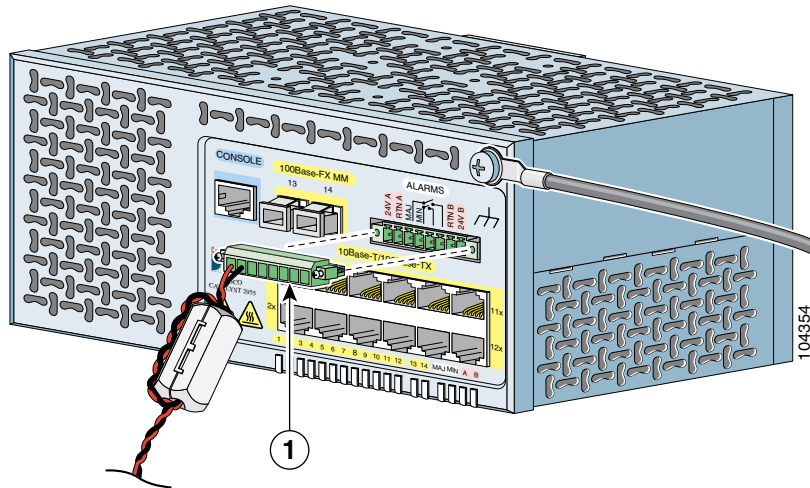

<b>1</b>	Power and relay connector
----------	---------------------------

## Power On the Switch



### Caution

Remove the protective liner before applying power to the switch.

Failure to remove the protective liner could result in thermal damage to the switch.

Locate the circuit breaker on the panel board that services the DC circuit, and switch the circuit breaker to the ON position.

## Running POST

After the power is connected, the switch automatically begins POST, a series of tests that verifies that the switch functions properly.



### Note

The uplink port status LEDs provide system and status information during POST. On the Catalyst 2955C-12 and 2955S-12, the uplink ports are labeled 13 and 14. On the Catalyst 2955T-12, the uplink ports are labeled 1 and 2.



### Warning

**If you connect or disconnect the console cable with power applied to the switch or any device on the network, an electrical arc can occur. This could cause an explosion in hazardous location installations. Be sure that power is removed or the area is nonhazardous before proceeding.**

**To verify switch operation, perform POST on the switch in a nonhazardous location before installation.** Statement 1065

When the Catalyst 2955C-12 and 2955S-12 begin POST:

- Uplink port 13 LED is amber.
- Uplink port 14 LED blinks green.

When the Catalyst 2955T-12 begins POST:

- Uplink port 1 LED is amber.
- Uplink port 2 LED blinks green.

If POST completes successfully on the Catalyst 2955C-12 and 2955S-12:

- Uplink port 13 LED turns green.
- Uplink port 14 LED goes off during the flash file system initialization.

If POST completes successfully on the Catalyst 2955T-12:

- Uplink port 1 LED turns green.
- Uplink port 2 LED goes off during the flash file system initialization.

If POST fails on the Catalyst 2955C-12 and 2955S-12:

- Uplink port 13 LED blinks amber.
- Uplink port 14 LED turns green.

If POST fails on the Catalyst 2955T-12:

- Uplink port 1 LED blinks amber.
- Uplink port 2 LED turns green.

While the switch powers on, the power status LEDs are green or red, showing the presence or absence of power supplies (see [Table 2-1 on page 2-13](#) for details). During POST, the power status LEDs are green. After POST completes successfully, the power status LEDs are green if both power supplies are functioning normally and the switch has been configured to operate in dual-power mode.

If the switch is in single-power mode and only power supply A is present and functioning, the LED for power supply B is green, and the LED for power supply A shows its status. If the switch is in single-power mode and only power supply B is present and functioning, the LED for power supply A is green, and the LED for power supply B shows its status.

See the switch configuration guide for details on single- and dual-power mode operation.

On a Catalyst 2950 switch, you can use the MODE button to recover the switch password. The Catalyst 2955 switch has no MODE button, so the boot loader compensates by using break key detection to stop the automatic boot sequence for password recovery.

On the Catalyst 2955C-12 and 2955S-12 switches, during the initial appearance of the boot loader prompt on the console after POST, uplink port 13 LED blinks green, and uplink port 14 LED is off. On the Catalyst 2955T-12 switch, during the initial appearance of the boot loader prompt on the console after POST, uplink port 1 LED blinks green, and uplink port 2 LED is off.

**Note**

POST failures are usually fatal. Call Cisco Systems immediately if your switch does not pass POST. See the [“Obtaining Technical Assistance”](#) section on page xxviii.

**Note**

See the switch software configuration guide for details on the Catalyst 2955 switch password recovery process.

After successfully running POST, follow these steps.

- Step 1** Turn off power to the switch.
- Step 2** Disconnect the cables.
- Step 3** Decide where you want to install the switch.

## Wiring the External Alarm Device Relays

The alarm relays on the Catalyst 2955 switch are normally open (NO). To connect an external alarm device to the relays, you must connect two relay contact wires to complete an electrical circuit. Because each external alarm device requires two connections to a relay, the Catalyst 2955 switch supports a maximum of two external alarm devices.

**Warning**

The switch relays are rated at 1 Amp and have a voltage limit of 30 VDC and 0.3 Amp at a voltage limit of 125 VAC. It is dangerous to exceed these limitations in a hazardous environment.

**An electrical arc can occur when you connect or disconnect the relay wires with field side power applied. This could cause an explosion in switch installations in a hazardous location. Before proceeding, be sure that power is removed or the area is not hazardous.** Statement 1061.

**Note**

For wire connections to the power and relay connector, you must use UL and CSA rated, style 1007 or 1569 twisted-pair copper appliance wiring material (AWM) wire (such as Belden part number 9318).

You must also use the ferrite that ships with the switch.

After you have completed the wiring for the DC power connections, follow these steps to wire the switch to an external alarm device:

**Note**

This procedure is optional.

- Step 1** Measure one strand of twisted-pair wire (18 to 20 AWG) long enough to connect to the external alarm device.
- Step 2** Use a wire stripper to remove the casing from both ends of the wire to 0.25 inch (6.3 mm)  $\pm$  0.02 inch (0.5 mm). Do not strip more than 0.27 inch (6.8 mm) of insulation from the wire. Stripping more than the recommended amount of wire can leave exposed wire from the power and relay connector after installation.
- Step 3** Insert the exposed wires for the external alarm device into the two connections labeled A1, as shown in [Figure 4-13](#).

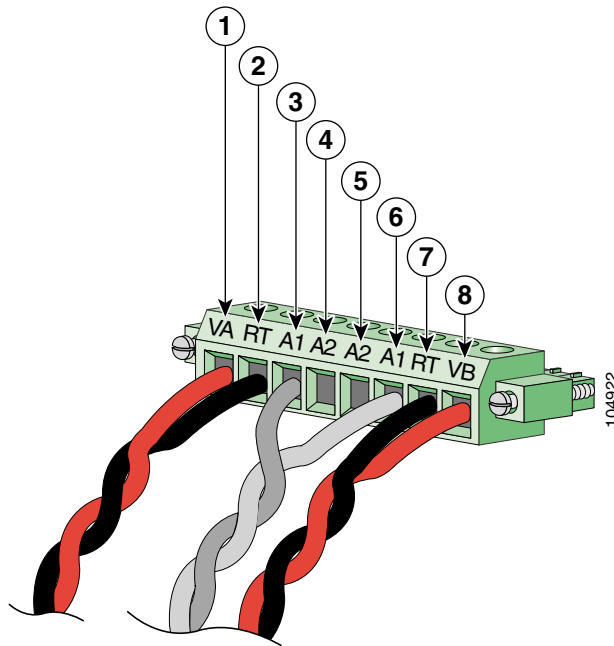
**Figure 4-13** Inserting Relay Wires into the Power and Relay Connector

<b>1</b>	Power supply A positive connection	<b>5</b>	External device 2, relay wire B connection
<b>2</b>	Power supply A return connection	<b>6</b>	External device 1, relay wire B connection
<b>3</b>	External device 1, relay wire A connection	<b>7</b>	Power supply B return connection
<b>4</b>	External device 2, relay wire A connection	<b>8</b>	Power supply B positive connection

**Step 4** Use a ratcheting torque flathead screwdriver to torque the power and relay connector captive screw (above the installed wire lead) to 4.5 in-lbs. (72 ozf-in.). (See [Figure 4-14](#) for details.)

**Caution**

Do not overtorque the power and relay connector captive screws. The recommended maximum torque is 4.5 in-lbs.

**Figure 4-14** Torquing the Power and Relay Connector Captive Screws

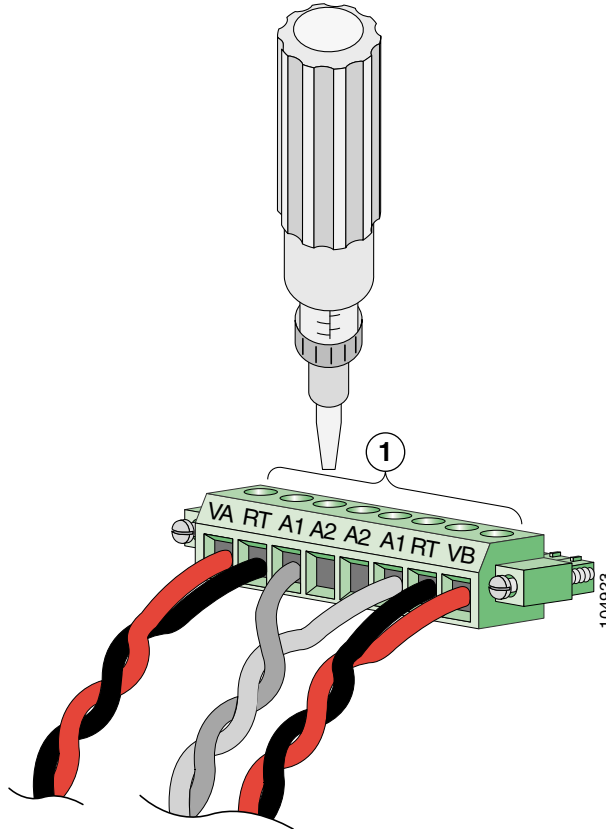

**1** Power and relay connector captive screws

**Step 5** Repeat [Step 1](#) through [Step 4](#) to insert the input and output wires of an additional external alarm device into the two connections labeled A2.

Figure 4-15 shows the completed wiring for two external alarm devices on a power and relay connector.

**Figure 4-15** Completed Connections for Two External Alarm Devices on the Power and Relay Connector

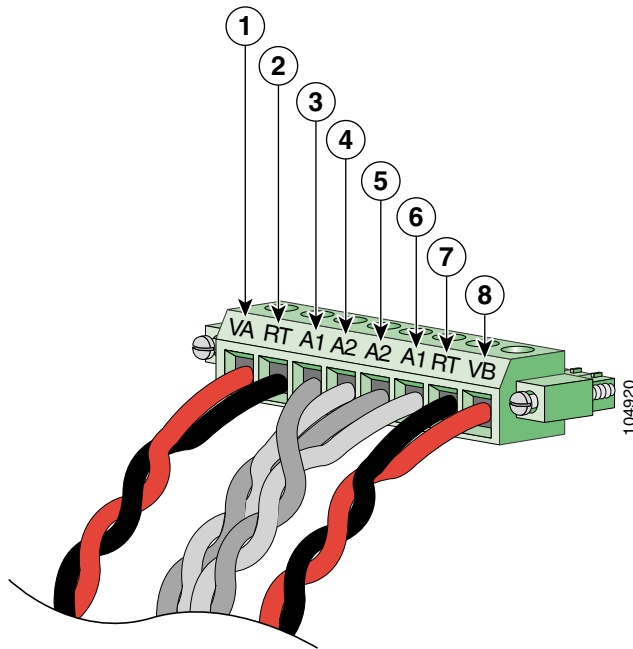

1	Power supply A positive connection	5	External device 2, relay wire B connection
2	Power supply A return connection	6	External device 1, relay wire B connection
3	External device 1, relay wire A connection	7	Power supply B return connection
4	External device 2, relay wire A connection	8	Power supply B positive connection



**Note**

See the “[Add the Ferrite to the Power and Relay Connector Wiring](#)” section on [page 4-27](#) for instructions on how to attach the ferrite to the power and relay connector wiring.

See the “[Attach the Power and Relay Connector to the Switch](#)” section on [page 4-28](#) for instructions on how to connect the power and relay connector to the front panel.

## Installing the Switch on a DIN Rail

You can mount the Catalyst 2955 switch on a DIN rail in a parallel or a face-down position.

**Warning**

**This equipment is supplied as “open type” equipment. It must be mounted within an enclosure that is suitably designed for those specific environmental conditions that will be present and appropriately designed to prevent personal injury resulting from accessibility to live parts. The interior of the enclosure must be accessible only by the use of a tool.**

**The enclosure must meet IP 54 or NEMA type 4 minimum enclosure rating standards.** Statement 1063

**Warning**

**When used in a Class I, Division 2, hazardous location, this equipment must be mounted in a suitable enclosure with proper wiring method, for all power, input and output wiring, that complies with the governing electrical codes and in accordance with the authority having jurisdiction over Class I, Division 2 installations.** Statement 1066

**Caution**

To prevent the switch from overheating, there must be a minimum of 3 inches between any other device and the top, bottom, or sides of the switch.

The switch ships with the clip assembly installed on the rear panel for a parallel mounting position, as shown in [Figure 4-16](#). To mount the switch in a face-down position, remove the clip assembly from the rear panel, and install it on the top of the switch, as shown in [Figure 4-17](#).

**Figure 4-16** Catalyst 2955 Switch Rear Panel Clip Mounting

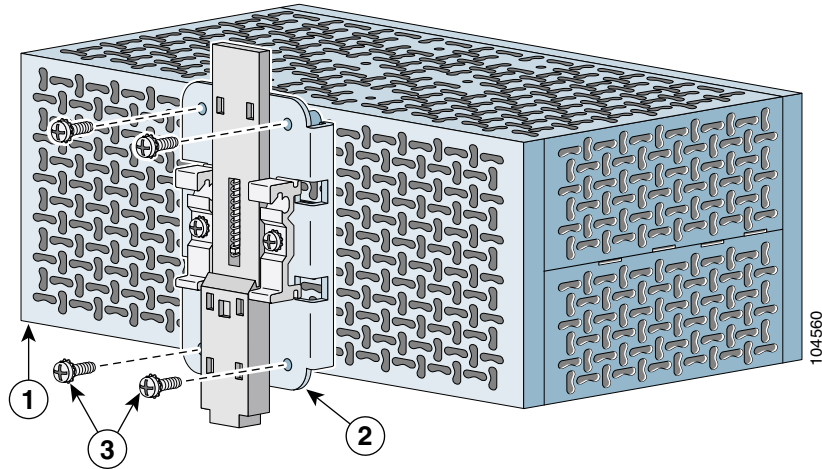

<b>1</b>	Catalyst 2955 switch rear panel	<b>3</b>	DIN rail clip mounting screws
<b>2</b>	DIN rail clip assembly		

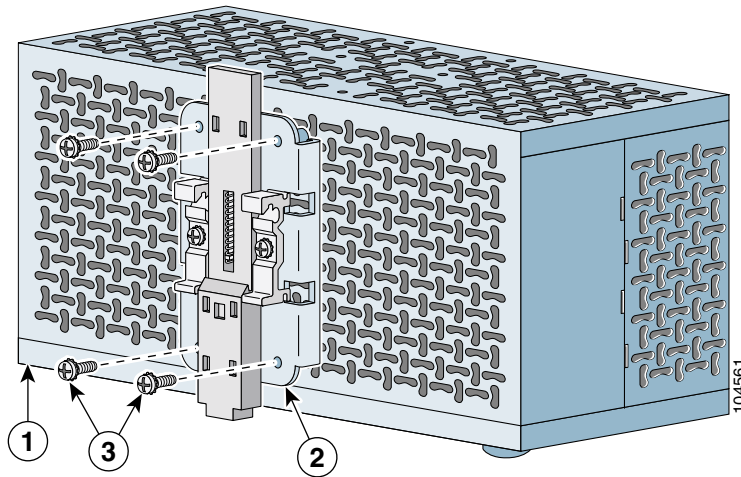
**Figure 4-17 Catalyst 2955 Switch Top Panel Clip Mounting**

<b>1</b>	Catalyst 2955 switch top panel	<b>3</b>	DIN rail clip mounting screws
<b>2</b>	DIN rail clip assembly		

To attach the switch to a DIN rail, follow these steps.

- Step 1** Position the rear panel of the switch directly in front of the DIN rail, making sure that the top of the DIN rail clip hooks over the top of the DIN rail, as shown in [Figure 4-18](#) and [Figure 4-19](#).

**Figure 4-18** *Mounting the Switch on a DIN Rail in a Parallel Position*

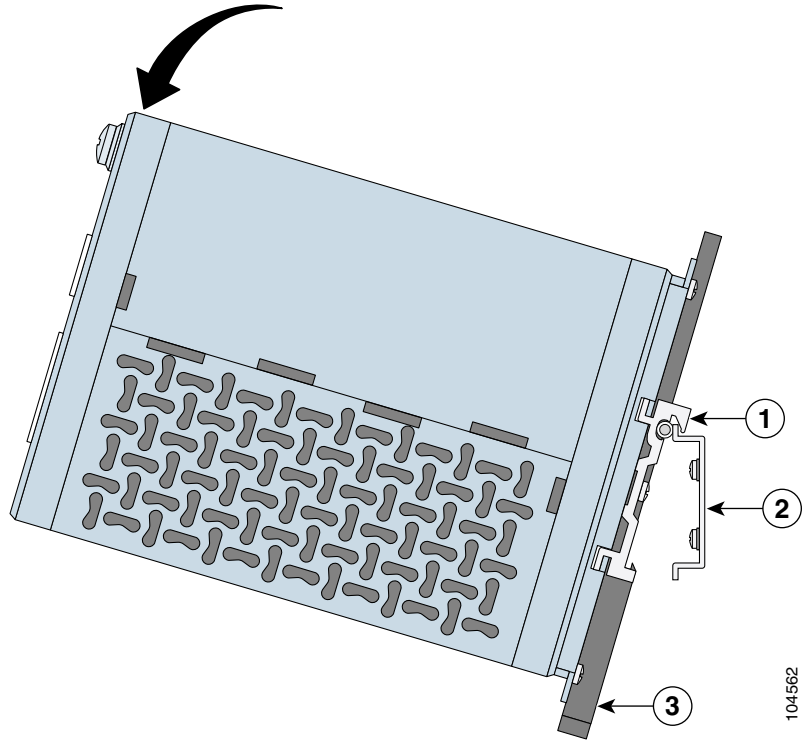

<b>1</b>	DIN rail clip	<b>3</b>	DIN rail clip release tab
<b>2</b>	DIN rail		

104562

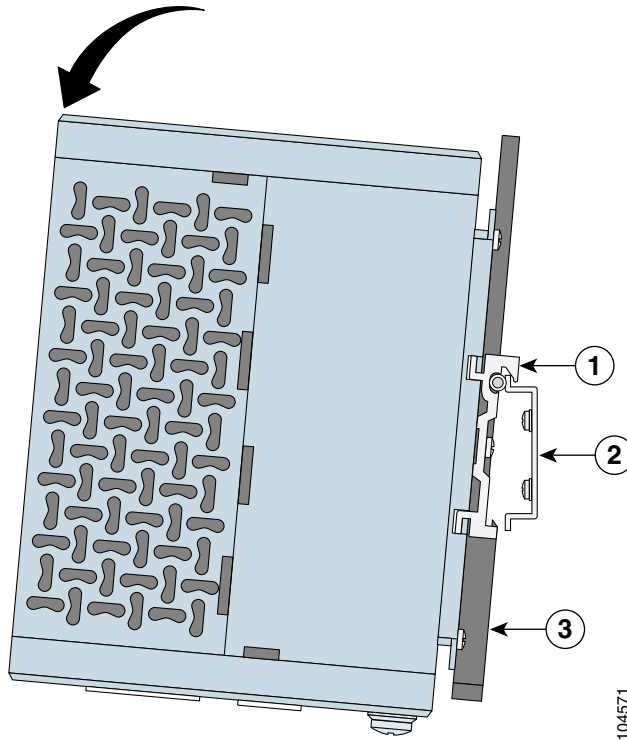
**Figure 4-19** *Mounting the Switch on a DIN Rail in a Face-Down Position*

<b>1</b>	DIN rail clip	<b>3</b>	DIN rail clip release tab
<b>2</b>	DIN rail		

- Step 2** Rotate the switch down toward the DIN rail until the release tab on the rear panel clicks.
- Step 3** Lift lightly on the bottom of the switch to ensure that it is firmly locked in place.

After the switch is mounted on the DIN rail, power on the switch as described in the “Powering On the Switch and Running POST” section on page 4-16.

**Note**

---

For instructions on how to remove the switch from a DIN rail, see the [“Removing the Switch from a DIN Rail or a Rack”](#) section on page 4-45.

---

## Installing the Switch in a Rack

You can use an optional DIN rail adapter kit (available through Cisco, part number STK-RACKMNT-2955=) to mount the Catalyst 2955 switch in a 19-inch rack. The rack mounting kit comes with a DIN rail adapter and screws to attach the adapter to the rack. Ask your Cisco representative for details.

**Warning**

---

**To prevent bodily injury when mounting or servicing this unit in a rack, you must take special precautions to ensure that the system remains stable. The following guidelines are provided to ensure your safety:**

- **This unit should be mounted at the bottom of the rack if it is the only unit in the rack.**
  - **When mounting this unit in a partially filled rack, load the rack from the bottom to the top with the heaviest component at the bottom of the rack.**
  - **If the rack is provided with stabilizing devices, install the stabilizers before mounting or servicing the unit in the rack.** Statement 1006
- 

**Caution**

---

To prevent the switch from overheating, there must be a minimum of 3 inches between any other device and the top, bottom, or sides of the switch.

---

To install the switch in a rack, follow these steps:

- Step 1** Use the four Phillips machine screws to securely attach the brackets to the rack, as shown in [Figure 4-20](#).

**Figure 4-20** *Installing the DIN Rail Adapter*

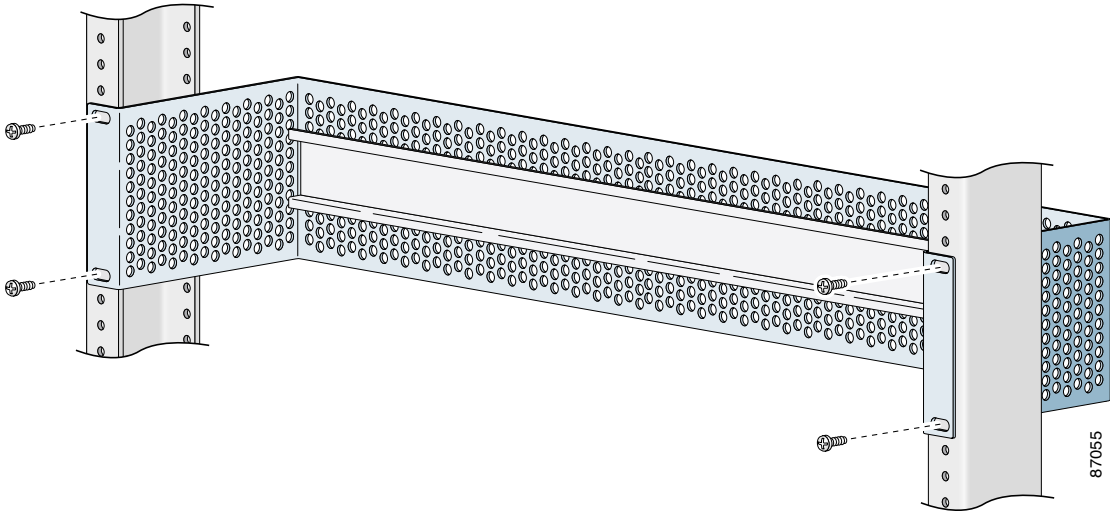

- Step 2** Position the rear panel of the switch directly in front of the DIN rail, making sure that the top of the DIN rail clip hooks over the top of the DIN rail, as shown in [Figure 4-18](#) and [Figure 4-19](#).
- Step 3** Rotate the switch down toward the DIN rail until the release tab on the rear panel clicks.
- Step 4** Lift lightly on the bottom of the switch to ensure that it is firmly locked in place. See [Figure 4-21](#) for details.

Figure 4-21 Installing the Switch in a Rack

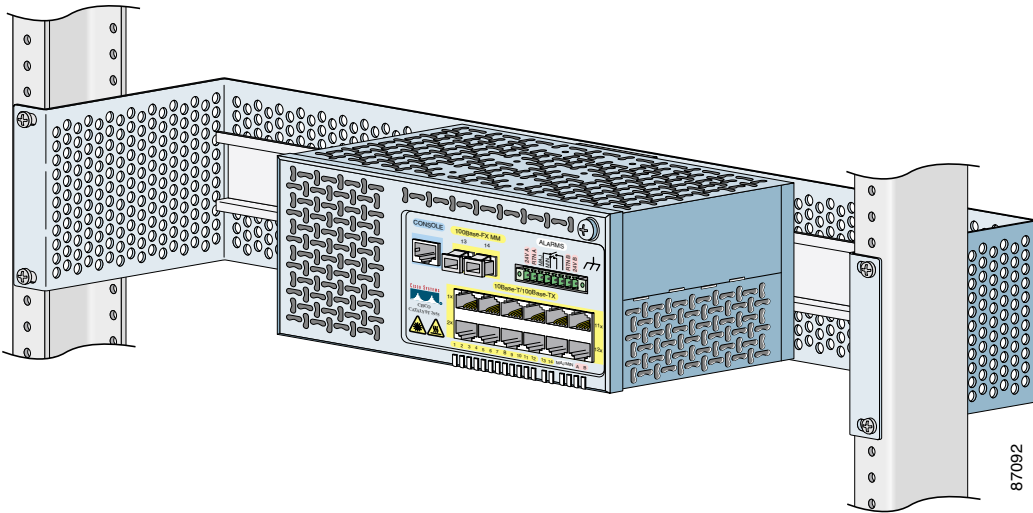

After mounting the switch in the rack, start the terminal-emulation software, and provide power to the switch. See the [“Powering On the Switch and Running POST”](#) section on page 4-16 for instructions.

**Note**

For instructions on how to remove the switch from a rack, see the [“Removing the Switch from a DIN Rail or a Rack”](#) section on page 4-45.



# Removing the Switch from a DIN Rail or a Rack

To remove the switch from a DIN rail or a rack, follow these steps:

- Step 1** Ensure that power is removed from the switch, and disconnect all cables and connectors from the front panel of the switch.
- Step 2** Push down on the top of the DIN rail clip release tab with your finger. As the clip releases, lift the bottom of the switch, as shown in [Figure 4-22](#) and [Figure 4-23](#).

**Figure 4-22** Removing the Switch from a Parallel Mounting Position

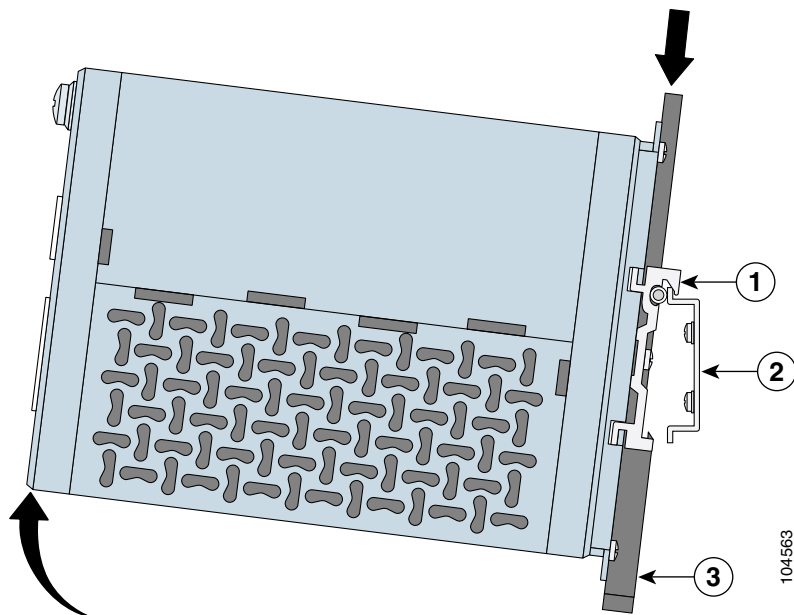

1	DIN rail clip	3	DIN rail clip release tab
2	DIN rail		

104563

Figure 4-23 Removing the Switch from a Face-Down Mounting Position

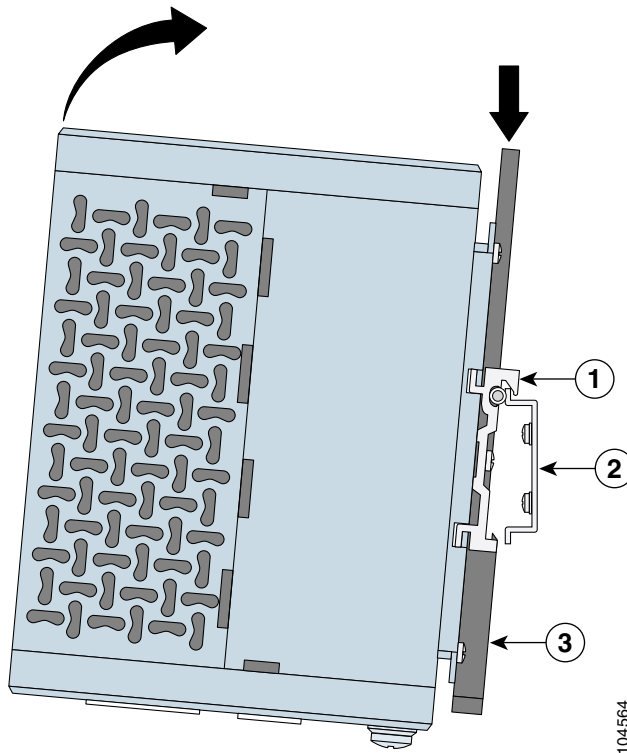

<b>1</b>	DIN rail clip	<b>3</b>	DIN rail clip release tab
<b>2</b>	DIN rail		

## Connecting to 10/100 and 10/100/1000 Ports

The 10/100 ports on the Catalyst 2955 configure themselves to operate at the speed and duplex settings of attached devices. They operate at 10 or 100 Mbps in half- or full-duplex mode. If the attached devices do not support autonegotiation, you can set the speed and duplex parameters.

The 10/100/1000 ports configure themselves to operate at the speed setting of attached devices. These ports on the Catalyst 2955T-12 operate at either 10 or 100 Mbps in either full- or half-duplex mode or at 1000 Mbps in full-duplex mode. If the attached devices do not support autonegotiation, you can set the speed parameter.

Connecting devices that do not autonegotiate or devices with manually set speed and duplex parameters can reduce performance or result in link failures between the devices. To maximize performance, choose one of these methods for configuring the ports:

- Let the ports autonegotiate both speed and duplex for 10/100 ports and speed for 10/100/1000 ports.
- Set the speed and duplex parameters on both ends of the connection.



### Warning

---

**Do not connect or disconnect cables to the ports while power is applied to the switch or any device on the network because an electrical arc can occur. This could cause an explosion in hazardous location installations. Be sure that power is removed from the switch and cannot be accidentally be turned on, or verify that the area is nonhazardous before proceeding.** Statement 1070

---



### Caution

---

Proper ESD protection is required whenever you handle Cisco equipment. Installation and maintenance personnel should be properly grounded using ground straps to eliminate the risk of ESD damage to the switch.

Do not touch connectors or pins on component boards. Do not touch circuit components inside the switch. When not in use, store the equipment in appropriate static-safe packaging.

---

Follow these steps to connect the switch to 10BASE-T, 100BASE-TX, or 1000BASE-T devices:

- Step 1** When connecting to servers, workstations, and routers, insert a twisted-pair straight-through cable in a front-panel RJ-45 connector, as shown in [Figure 4-24](#) and [Figure 4-25](#). When connecting to switches or repeaters, insert a twisted-pair crossover cable. (See the “Cable and Adapter Specifications” section on page B-5 for cable-pinout descriptions.)



**Note** When connecting to 1000BASE-T devices, be sure to use a four twisted-pair, Category 5 cable.

**Figure 4-24** Connecting to a 10/100 Port on the Catalyst 2955 Switch

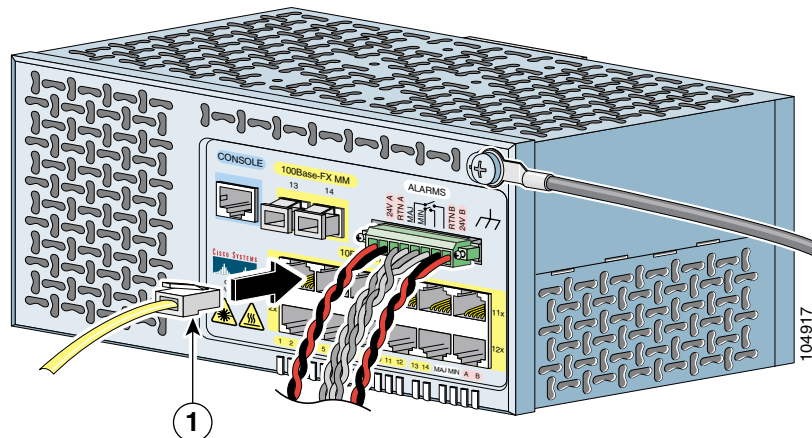

**1** Ethernet cable

**Figure 4-25** Connecting to a 10/100/1000 Port on the Catalyst 2955T-12 Switch

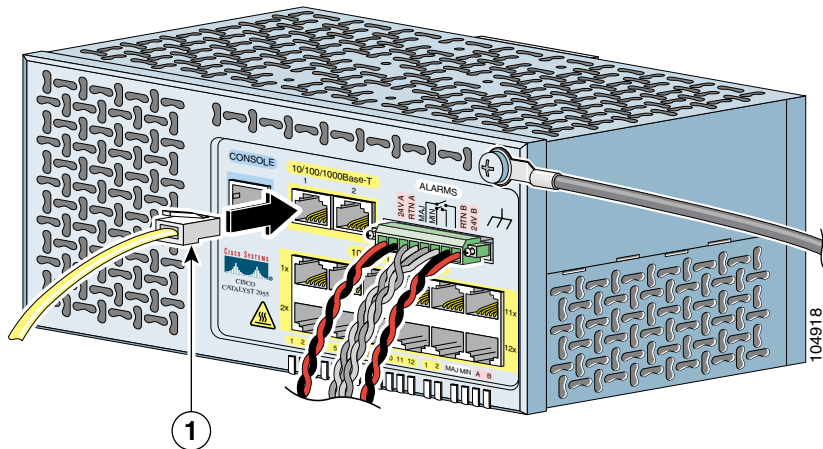

<b>1</b>	10/100/1000 Ethernet cable
----------	----------------------------

**Step 2** Insert the other cable end in an RJ-45 connector on the target device.

**Step 3** Observe the port status LED.

The LED turns green when the switch and the target device have an established link.

The LED turns amber while Spanning Tree Protocol (STP) discovers the network topology and searches for loops. This process can take about 30 seconds, and then the LED turns green.

If the LED is off, the target device might not be turned on, there might be a cable problem, or there might be a problem with the adapter installed in the target device. See [Chapter 5, “Troubleshooting,”](#) for solutions to cabling problems.

**Step 4** Reconfigure and restart the target device if necessary.

**Step 5** Repeat Steps 1 through 4 to connect each port.

# Connecting to 100BASE-FX MM Ports

The 100BASE-FX MM fiber-optic uplink ports operate in full-duplex mode.

You can connect a 100BASE-FX port to a port on a target device by using one of the MT-RJ fiber-optic patch cables listed in [Table B-1 on page B-3](#). Use the Cisco part numbers in [Table B-1](#) to order the patch cables that you need.



## Warning

**Do not connect or disconnect cables to the ports while power is applied to the switch or any device on the network because an electrical arc can occur. This could cause an explosion in hazardous location installations. Be sure that power is removed from the switch and cannot be accidentally be turned on, or verify that the area is nonhazardous before proceeding.** Statement 1070



## Warning

**Class 1 LED product.** Statement 1027



## Caution

Do not remove the dust plugs from the fiber-optic ports or the rubber caps from the fiber-optic cable until you are ready to connect the cable. The plugs and caps protect the fiber-optic ports and cables from contamination and ambient light.

Follow these steps to connect the switch to a MM 100BASE-FX device:

- Step 1** Remove the dust plugs from the 100BASE-FX port, as shown in [Figure 4-26](#), and store them for future use. Remove the rubber caps from the MT-RJ patch cable. Store them for future use.

**Figure 4-26** Removing Dust Plugs from 100BASE-FX Ports

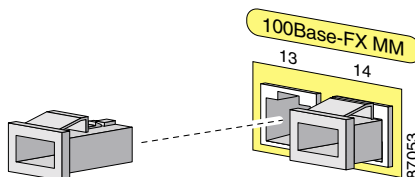



# Connecting to 100BASE-LX SM Ports

You can connect a 100BASE-LX port to a port on a target device by using one of the LC fiber-optic patch cables listed in [Table B-2 on page B-4](#). Use the Cisco part numbers in [Table B-2](#) to order the patch cables that you need.

Follow these steps to connect the switch to a 100BASE-LX SM device:



**Warning**

---

**Do not connect or disconnect cables to the ports while power is applied to the switch or any device on the network because an electrical arc can occur. This could cause an explosion in hazardous location installations. Be sure that power is removed from the switch and cannot be accidentally be turned on, or verify that the area is nonhazardous before proceeding.** Statement 1070

---



**Warning**

---

**Invisible laser radiation may be emitted from disconnected fibers or connectors. Do not stare into beams or view directly with optical instruments.** Statement 1051

---



**Warning**

---

**Avoid direct exposure to the laser beam.** Statement 1012

---



**Caution**

Do not remove the dust plugs from the fiber-optic ports or the rubber caps from the fiber-optic cable until you are ready to connect the cable. The plugs and caps protect the fiber-optic ports and cables from contamination and ambient light.

- Step 1** Remove the dust plugs from the 100BASE-LX port, as shown in [Figure 4-28](#), and store them for future use. Remove the rubber caps from the LC on the fiber-optic cable. Store them for future use.

**Figure 4-28** Removing Dust Plugs from 100BASE-LX Ports

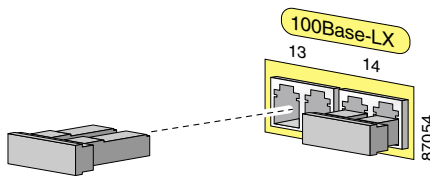

- Step 2** Insert the cable in a 100BASE-LX port. (See [Figure 4-29](#).)

**Figure 4-29** Connecting to a 100BASE-LX SM Port

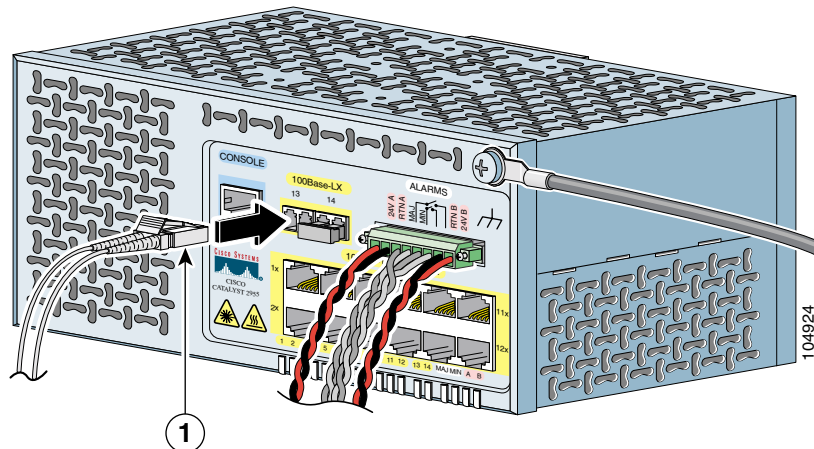

**1** Fiber-optic uplink cable

**Step 3** Insert the other cable end in an LC port on the target device.

**Step 4** Observe the port status LED.

The LED turns green when the switch and the target device have an established link.

The LED turns amber while STP discovers the network topology and searches for loops. This process can take about 30 seconds, and then the port LED turns green.

If the LED is off, the target device might not be turned on, there might be a cable problem, or there might be a problem with the adapter installed in the target device. See [Chapter 5, “Troubleshooting,”](#) for solutions to cabling problems.

**Step 5** Reconfigure and restart the target device, if necessary.

**Step 6** Repeat Steps 1 through 5 to connect each port.

---

## Where to Go Next

If the default configuration is satisfactory, the switch does not need further configuration. You can use any of these management options to change the default configuration:

- Start the device manager, which is in the switch memory, to manage individual and standalone switches. The device manager is an easy-to-use web interface that offers quick configuration and monitoring. You can access the device manager from anywhere in your network through a web browser. For more information, see the device manager online help.
- Start the Network Assistant application, which is described in the *Getting Started with Cisco Network Assistant* guide on Cisco.com. Through this GUI, you can configure and monitor a switch cluster or an individual switch.
- Use the CLI from the console to configure the switch as a member of a cluster or as an individual switch. See the *Catalyst 2950 and Catalyst 2955 Switch Software Configuration Guide* and the *Catalyst 2950 and Catalyst 2955 Switch Command Reference* on Cisco.com for information on using the CLI with a Catalyst 2955 switch.
- Start an SNMP application such as the CiscoView application.



# Troubleshooting

---

The front-panel LEDs provide troubleshooting information about the switch. They show power-on self-test (POST) failures, port-connectivity problems, and overall switch performance. For a full description of the LEDs, see the [“LEDs” section on page 2-10](#).

You can also get statistics from the browser interface, the command-line interface (CLI), the Cisco Intelligence Engine 2100 (IE2100) Series Configuration Registrar, or a Simple Network Management Protocol (SNMP) workstation. See the switch software configuration guide, the switch command reference, or the documentation that came with your IE2100 or SNMP application for details.

This chapter provides these topics for troubleshooting problems:

- [Understanding POST Results, page 5-2](#)
- [Diagnosing Problems, page 5-3](#)

# Understanding POST Results

After the power is connected, the switch automatically begins POST, a series of tests that verifies that the switch functions properly.

**Note**

---

The uplink port status LEDs provide system and status information during POST. On the Catalyst 2955C-12 and 2955S-12, the uplink ports are labeled 13 and 14. On the Catalyst 2955T-12, the uplink ports are labeled 1 and 2.

---

**Warning**

---

**If you connect or disconnect the console cable with power applied to the switch or any device on the network, an electrical arc can occur. This could cause an explosion in hazardous location installations. Be sure that power is removed or the area is nonhazardous before proceeding.**

---

**To verify switch operation, perform POST on the switch in a nonhazardous location before installation.** Statement 1065

---

When the Catalyst 2955C-12 and 2955S-12 begin POST:

- Uplink port 13 LED is amber.
- Uplink port 14 LED blinks green.

When the Catalyst 2955T-12 begins POST:

- Uplink port 1 LED is amber.
- Uplink port 2 LED blinks green.

If POST completes successfully on the Catalyst 2955C-12 and 2955S-12:

- Uplink port 13 LED turns green.
- Uplink port 14 LED goes off during the flash file system initialization.

If POST completes successfully on the Catalyst 2955T-12:

- Uplink port 1 LED turns green.
- Uplink port 2 LED goes off during the flash file system initialization.

If POST fails on the Catalyst 2955C-12 and 2955S-12:

- Uplink port 13 LED blinks amber.
- Uplink port 14 LED turns green.

If POST fails on the Catalyst 2955T-12:

- Uplink port 1 LED blinks amber.
- Uplink port 2 LED turns green.

**Note**

---

The uplink port status LEDs provide system and status information during POST. On the Catalyst 2955T-12, the uplink ports are labeled 1 and 2. On the Catalyst 2955C-12 and 2955S-12, the uplink ports are labeled 13 and 14.

POST failures are usually fatal. Call Cisco Systems immediately if your switch does not pass POST. See the [“Obtaining Technical Assistance”](#) section on page xxviii.

---

## Diagnosing Problems

Common switch problems fall into these categories:

- Poor performance
- No connectivity
- Corrupted software

Table 5-1 describes how to detect and solve these problems.

**Table 5-1 Common Problems and Solutions**

Symptom	Possible Cause	Resolution
<b>Poor performance or excessive errors.</b>	Duplex autonegotiation mismatch.	See the switch software configuration guide for information about identifying autonegotiation mismatches.
	<b>Cabling distance exceeded.</b> <ul style="list-style-type: none"> <li>• Port statistics show excessive frame check sequence (FCS), late-collision, or alignment errors.</li> <li>• For 10BASE-T, 100BASE-TX, and 1000BASE-T connections:               <ul style="list-style-type: none"> <li>– The distance between the port and the attached device exceeds 328 feet (100 meters).</li> </ul> </li> <li>• For 100 and 1000 speed connections:               <ul style="list-style-type: none"> <li>– Wrong cable type (not Cat 5) attached to device and switch</li> <li>– If the switch is attached to a repeater, the total distance between the two end stations exceeds the cabling guidelines.</li> </ul> </li> </ul> <b>Bad adapter in attached device.</b> <ul style="list-style-type: none"> <li>• Excessive errors found in port statistics.</li> </ul>	<ul style="list-style-type: none"> <li>• See the switch software configuration guide for information about displaying port statistics.</li> <li>• Reduce cable length to within the recommended distances.</li> <li>• Replace wrong cable type with Cat 5 cable.</li> <li>• See your repeater documentation for cabling guidelines.</li> <li>• Run adapter card diagnostic utility.</li> </ul>
	<b>Spanning Tree Protocol (STP) checking for possible loops.</b>	Wait 30 seconds for port status LED to turn green.

Table 5-1 Common Problems and Solutions (continued)

Symptom	Possible Cause	Resolution
No connectivity.	<p><b>Incorrect or bad cable.</b></p> <p>No link at both ends.</p> <ul style="list-style-type: none"> <li>• A crossover cable was used when a straight-through was required, or vice-versa.</li> <li>• The cable is wired incorrectly.</li> <li>• STP checking for possible loops.</li> </ul>	<ul style="list-style-type: none"> <li>• For the correct pinouts and the proper application of crossover vs. straight-through cables, see the “<a href="#">Cable and Adapter Specifications</a>” section on page B-5.</li> <li>• Replace it with a tested good cable.</li> <li>• Wait 30 seconds for port status LED to turn green.</li> </ul>
Unreadable characters on the management console.	Incorrect baud rate.	Reset the terminal-emulation software to 9600 baud.
System LED (Uplink port status 13 LED) is amber, and all port LEDs are off.	Corrupted software.	Attach a monitor to the serial port to display the switch boot loader. For more information, see the switch software configuration guide.
System LED (Uplink port 13 LED) is amber.	<ul style="list-style-type: none"> <li>• Fatal POST error detected.</li> </ul>	<ul style="list-style-type: none"> <li>• Contact Cisco Systems.</li> </ul>







## Technical Specifications

---

[Table A-1](#) lists the technical specifications for the Catalyst 2955 switches. [Table A-2](#) and [Table A-3](#) list the technical specifications for fiber-optic uplink ports. [Table A-4](#) lists the regulatory agency approvals. [Table A-5](#) lists the technical specifications for the Catalyst 2955 switch power converter. [Table A-6](#) lists the regulatory agency approvals for the Catalyst 2955 switch power converter.

**Table A-1**      **Technical Specifications for Catalyst 2955T-12, 2955C-12, and Catalyst 2955S-12 Switches**

<b>Environmental Ranges</b>	
Operating temperature	–40 to 140°F (–40 to 60°C)
Storage temperature	–40 to 185°F (–40 to 85°C)
Operating humidity	10 to 95% (noncondensing)
Shock	50 g at 11 ms
Operating altitude	Up to 10,000 ft (3000 m)
Storage altitude	Up to 30,000 ft (9000 m)
<b>Power Requirements</b>	
DC input voltages	24 V (18 minimum to 32 V maximum range)  <b>Note</b> The DC-input power supply is an SELV circuit, and it can only be connected to another SELV circuit.
Power consumption	23 W (maximum)  102 BTUs per hour
<b>Physical Dimensions</b>	
Weight	3.1 lbs (1.4 kg)
Dimensions (W x D x H)	8.07 x 5.03 x 3.75 in. (20.5 x 12.78 x 9.53 cm)

**Table A-2** *Fiber-Optic Port Specifications for the Catalyst 2955C-12 Switch*

<b>Fiber-Port Power Levels</b>	<b>Catalyst 2955C-12 (100BASE-FX MM)</b>
Optical transmitter wavelength	1300 nm <sup>1</sup>
Optical receiver sensitivity for 50/125-micron cabling	-33.5 to -11.8 dBm <sup>2</sup>
Optical receiver sensitivity for 62.5/125-micron cabling	-33.5 to -11.8 dBm
Optical transmitter power for 50/125-micron cabling	-23.5 to -14 dBm
Optical transmitter power for 62.5/125-micron cabling	-20 to -14 dBm

1. nm = nanometers
2. dBm = decibel milliwatt

**Table A-3** *Fiber-Optic Port Specifications for the Catalyst 2955S-12 Switch*

<b>Fiber-Port Power Levels</b>	<b>Catalyst 2955S-12 (100BASE-LX SM<sup>1</sup>)</b>
Optical transmitter wavelength	1300 nm <sup>2</sup>
Optical receiver sensitivity for 9/125-micron SM cabling	-38 to -31 dBm <sup>3</sup>
Optical transmitter power for 9/125-micron cabling	-15 to -8 dBm

1. SM = single-mode fiber
2. nm = nanometer
3. dBm = decibel milliwatt

**Table A-4** *Catalyst 2955 Switch Agency Approvals*

<b>Safety</b>	<b>EMC</b>	<b>Hazardous Locations</b>
UL 60950	FCC Part 15 Class A	UL 1604 – Class I, Div 2 Group A, B, C, D
CE	ICES-003 Class A	CSA 22.2/213 – Class I, Div 2 Group A, B, C, D
CAN 22.2 No. 60950	EN 55022: (CISPR22) Class A	EN 50021 – Class I, Zone 2
UL 508	EN 55024 (CISPR24)	
CB report to IEC 60950	AS/NZS CISPR 22 Class A	

**Table A-4** Catalyst 2955 Switch Agency Approvals (continued)

Safety	EMC	Hazardous Locations
TUV GS mark to EN60950	VCCI Class 1	
AS/NZS 3260	CE	
NOM	CNS 13438	
CSA 22.2/142	BSMI Class A	
	MIC Class A	
	EN 61131-2	
	EN 55011 (CISPR 11) Class A	

Table A-5 lists the technical specifications for the Catalyst 2955 switch power converter.

**Table A-5** Technical Specifications for the Power Converter

Environmental Ranges	
Operating temperature	14 to 140°F (–10 to 60°C)
Storage temperature	–13 to 185°F (–25 to 85°C)
Operating altitude	Up to 10,000 ft (3000 m)
Storage altitude	Up to 30,000 ft (9000 m)
Thermal spacing	0.39 in. (10 mm) sides 0.98 in. (25 mm) top and bottom

**Table A-5** *Technical Specifications for the Power Converter (continued)*

<b>Power Requirements</b>	
Input voltages	AC continuously 176-264 V (switch in 230 V position), 47-63 Hz  AC continuously 85-132 V (switch in 115 V position), 47-63 Hz  DC continuously 160-375 V (switch in 230 V position)
Maximum AC power input current	0.7 A @ 230 V 1.3 A @ 115 V
<b>Physical Dimensions</b>	
Weight	1.01 lbs (0.460 kg)
Dimensions (W x D x H)	1.97 x 4.05 x 4.92 in. (50 x 103 x 125 mm)

Table A-6 lists the regulatory agency approvals for the Catalyst 2955 switch power converter.

**Table A-6** *Power Converter Agency Approvals*

<b>Safety</b>	<b>EMC</b>
EN 60950	EN 50081-1 and -2 (Emissions)
EN 50178	EN 50082-1 and -2 (Immunity)
EN 55011	VDE 0160/W2 (Transient protection)
CB report to IEC 60950	CE
UL 60950 Recognition	
UL 508 Listing	
CSA 22.2 Number 950-M90	





## Connectors and Cables

---

This appendix describes the connectors, cables, and adapters that you use to connect the switch to other devices.

### Connector Specifications

These sections describe the connectors used with the Catalyst 2955 switches and contain this information:

- [10/100 and 10/100 /1000 Ports, page B-2](#)
- [100BASE-FX Ports, page B-3](#)
- [100BASE-LX Ports, page B-3](#)
- [Power and Relay Connector, page B-4](#)
- [Console Port, page B-5](#)

## 10/100 and 10/100 /1000 Ports

The 10/100 and 10/100/1000 Ethernet ports on Catalyst 2955 switches use standard RJ-45 connectors and Ethernet pinouts with internal crossovers.

[Figure B-1](#) and [Figure B-2](#) show the pinouts.

**Figure B-1** 10/100 Port Pinouts

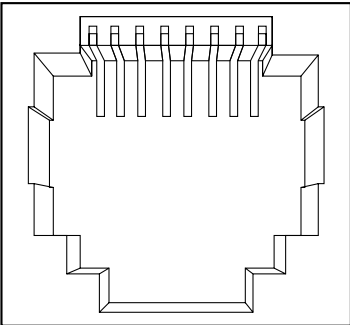
Pin	Label	1 2 3 4 5 6 7 8
1	RD+	
2	RD-	
3	TD+	
4	NC	
5	NC	
6	TD-	
7	NC	
8	NC	

H5318

**Figure B-2** 10/100/1000 Port Pinouts

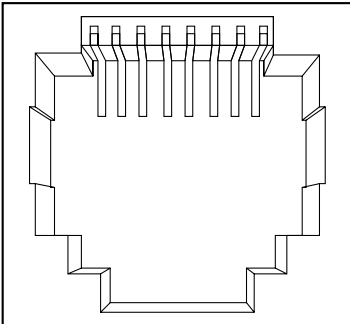
Pin	Label	1 2 3 4 5 6 7 8
1	TP0+	
2	TP0-	
3	TP1+	
4	TP2+	
5	TP2-	
6	TP1-	
7	TP3+	
8	TP3-	

60915



## 100BASE-FX Ports

The 100BASE-FX multimode (MM) fiber-optic ports use MT-RJ connectors, shown in [Figure B-3](#). These ports use 50/125- or 62.5/125-micron multimode fiber-optic cabling.

For MM connections, use one of the LCs listed in [Table B-1](#). Use the Cisco part numbers in [Table B-1](#) to order the patch cables that you need.

**Figure B-3** *MT-RJ Connector*

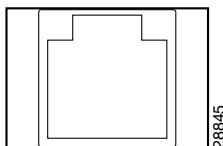

**Warning**

**Class 1 LED product.** Statement 1027

**Table B-1** *MT-RJ Patch Cables for 100BASE-FX Connections*

Type	Cisco Part Number
1-meter, MT-RJ-to-SC multimode cable	CAB-MTRJ-SC-MM-1M
3-meter, MT-RJ-to-SC multimode cable	CAB-MTRJ-SC-MM-3M
5-meter, MT-RJ-to-SC multimode cable	CAB-MTRJ-SC-MM-5M
1-meter, MT-RJ-to-ST multimode cable	CAB-MTRJ-ST-MM-1M
3-meter, MT-RJ-to-ST multimode cable	CAB-MTRJ-ST-MM-3M
5-meter, MT-RJ-to-ST multimode cable	CAB-MTRJ-ST-MM-5M

## 100BASE-LX Ports

The 100BASE-LX single-mode (SM) fiber-optic ports use LC-type connectors, shown in [Figure B-4](#). These ports use 9/125-micron single-mode fiber-optic cabling.

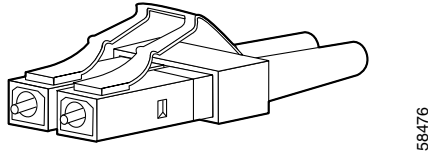
**Figure B-4** 100BASE-LX SM Port Connector**Warning**

**Invisible laser radiation may be emitted from disconnected fibers or connectors. Do not stare into beams or view directly with optical instruments.**  
Statement 1051

**Warning**

**Class 1 laser product.** Statement 1008

For SM connections, use one of the LCs listed in [Table B-2](#). Use the Cisco part numbers in [Table B-2](#) to order the connectors that you need.

**Table B-2** LC Patch Cables for 100BASE-LX Connections

Type	Cisco Part Number
2-meter, LC-to-SC single-mode cable	CAB-CP-LCSC-2M
8-inch, SC-to-LC single-mode cable	CAB-CP-SCLC-8IN
10-foot, LC-to-SC single-mode cable	CAB-SMF-SC-10
100-foot, LC-to-SC single-mode cable	CAB-SMF-SC-100
25-foot, LC-to-SC single-mode cable	CAB-SMF-SC-25
50-foot, LC-to-SC single-mode cable	CAB-SMF-SC-50
75-foot, LC-to-SC single-mode cable	CAB-SMF-SC-75

## Power and Relay Connector

The power and relay connector is a pluggable-screw terminal block connector that provides power and return connections for both the primary and secondary power supplies. The power and relay connector also gives the Catalyst 2955 switch the interfaces to two independent alarm relays.

**Note**

You can get replacement power and relay connectors (PWR-2955-CONNECT=) by calling Cisco Technical Support. See the [“Obtaining Technical Assistance”](#) section on page xxviii.

**Figure B-5** Power and Relay Connector

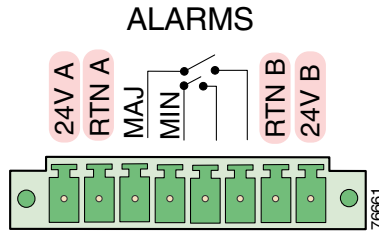

## Console Port

The console port uses an 8-pin RJ-45 connector. You can connect a switch to a PC through the console port and the supplied RJ-45-to-DB-9 adapter cable. If you want to connect a switch to a terminal, you need to provide an RJ-45-to-DB-25 female DTE adapter. You can order a kit (part number ACS-DSBUASYN=) with that adapter from Cisco. For console-port and adapter-pinout information, see [Table B-3](#) and [Table B-4](#).

## Cable and Adapter Specifications

These sections describe the cables and adapters used with Catalyst 2955 switches.

- [Two Twisted-Pair Cable Pinouts](#), page B-6
- [Four Twisted-Pair Cable Pinouts for 10/100 Ports](#), page B-6
- [Four Twisted-Pair Cable Pinouts for 1000BASE-T Ports](#), page B-8

## Two Twisted-Pair Cable Pinouts

Figure B-6 and Figure B-7 show the schematics of two twisted-pair cables for 10/100 ports.

**Figure B-6** *Two Twisted-Pair Straight-Through Cable Schematic for 10/100 Ports*

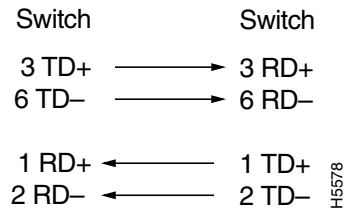

**Figure B-7** *Two Twisted-Pair Crossover Cable Schematic for 10/100 Ports*

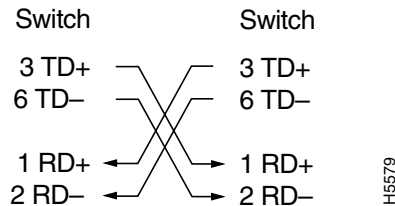

## Four Twisted-Pair Cable Pinouts for 10/100 Ports

Figure B-8 and Figure B-9 show the schematics of four twisted-pair cables for 10/100 ports.

**Figure B-8 Four Twisted-Pair Straight-Through Cable Schematic for 10/100 Ports**

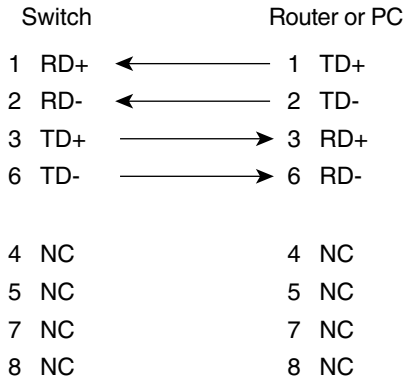

65271

**Figure B-9 Four Twisted-Pair Crossover Cable Schematic for 10/100 Ports**

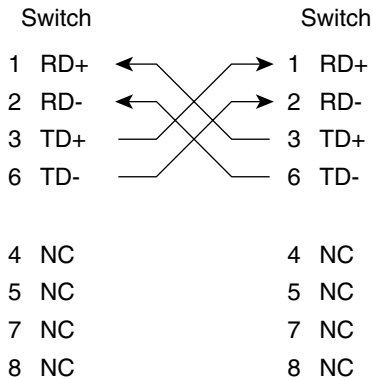

65273

## Four Twisted-Pair Cable Pinouts for 1000BASE-T Ports

Figure B-10 and Figure B-11 show the schematics of four twisted-pair cables for 10/100/1000 ports on Catalyst 2955T-12 switches and 1000BASE-T ports.

**Figure B-10** *Four Twisted-Pair Straight-Through Cable Schematic for 10/100/1000 and 1000BASE-T Ports*

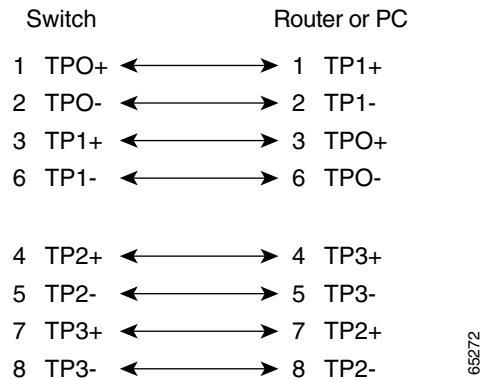

**Figure B-11** *Four Twisted-Pair Crossover Cable Schematics for 10/100/1000 and 1000BASE-T Ports*

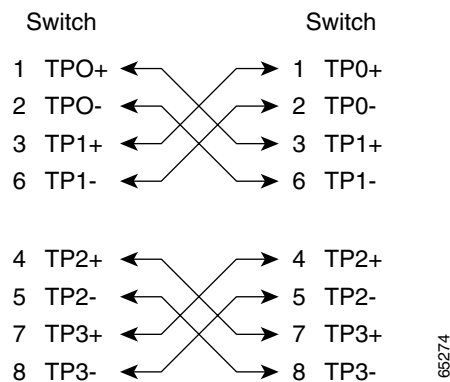

## Cable and Adapter Pinouts

This section describes the cable and adapter pinouts and also describes how to identify a rollover cable.

### Connecting to a PC

Use the supplied RJ-45-to-DB-9 adapter cable to connect the console port to a PC running terminal-emulation software. [Figure B-12](#) shows how to connect the console port to a PC. [Table B-3](#) lists the pinouts for the console port and the RJ-45-to-DB-9 adapter cable.

**Figure B-12** Connecting the Console Port to a PC

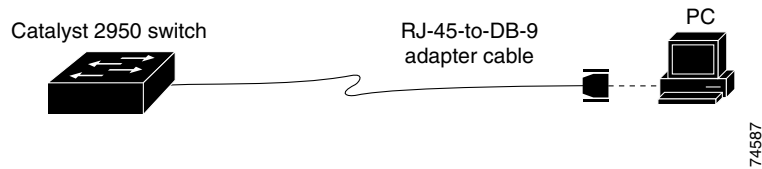

**Table B-3** Console Port Signaling and RJ-45-to-DB-9 Adapter Cabling

Console Port (DTE)	RJ-45-to-DB-9 Adapter Cable		Console Device
Signal	RJ-45 Pin	DB-9 Pin	Signal
RTS	1	8	CTS
Not connected	2	6	DSR
TxD	3	2	RxD
GND	4	5	GND
GND	5	5	GND
RxD	6	3	TxD
Not connected	7	4	DTR
CTS	8	7	RTS

## Connecting to a Terminal

Use the supplied RJ-45-to-DB-9 adapter cable and an RJ-45-to-DB-25 female DTE adapter to connect the console port to a terminal. [Figure B-13](#) shows how to connect the console port to a terminal. [Table B-4](#) lists the pinouts for the console port, the adapter cable, and the RJ-45-to-DB-25 adapter.



### Note

The RJ-45-to-DB-25 female DTE adapter is not supplied with the switch. You can order a kit (part number ACS-DSBUASYN=) with that adapter from Cisco.

**Figure B-13** Connecting the Console Port to a Terminal

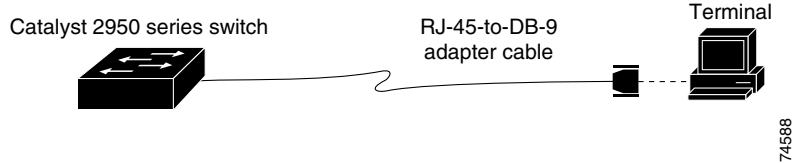

**Table B-4** Console Port Signaling and Cabling Using a DB-25 Adapter

Console Port (DTE)	RJ-45-to-DB-9 Adapter Cable		RJ-45-to-DB-25 Terminal Adapter	Console Device
	RJ-45 Pin	DB-9 Pin	DB-25 Pin	
RTS	1	8	5	CTS
Not connected	2	6	6	DSR
TxD	3	2	3	RxD
GND	4	5	7	GND
GND	5	5	7	GND
RxD	6	3	2	TxD
Not connected	7	4	20	DTR
CTS	8	7	4	RTS



## Identifying a Crossover Cable

To identify a crossover cable, compare the two modular ends of the cable. Hold the cable ends side-by-side, with the tab at the back. The wire connected to the pin on the outside of the left plug should be the same color as the wire connected to the pin on the outside of the right plug. (See [Figure B-14](#).)

**Figure B-14** Identifying a Crossover Cable

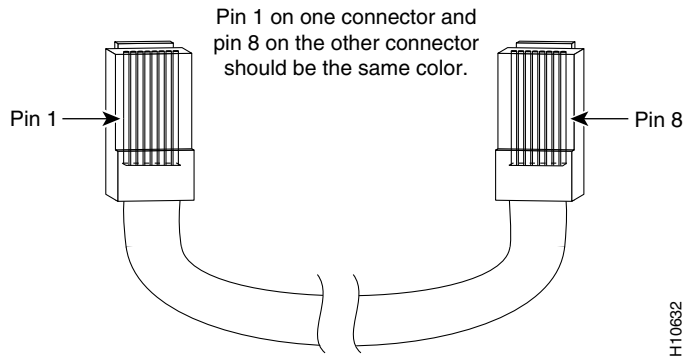





## Translated Safety Warnings

---

This appendix repeats in multiple languages the warnings in this guide. These translated warnings can be used with other documents related to this guide.

### Work During Lightning Activity



**Warning**

**Do not work on the system or connect or disconnect cables during periods of lightning activity.** Statement 1001

**Waarschuwing**

**Tijdens onweer dat gepaard gaat met bliksem, dient u niet aan het systeem te werken of kabels aan te sluiten of te ontkoppelen.**

**Varoitus**

**Älä työskentele järjestelmän parissa äläkä yhdistä tai irrota kaapeleita ukkosilmalla.**

**Attention**

**Ne pas travailler sur le système ni brancher ou débrancher les câbles pendant un orage.**

**Warnung**

**Arbeiten Sie nicht am System und schließen Sie keine Kabel an bzw. trennen Sie keine ab, wenn es gewittert.**

**Avvertenza**

**Non lavorare sul sistema o collegare oppure scollegare i cavi durante un temporale con fulmini.**

■ Work During Lightning Activity

<b>Advarsel</b>	<b>Utfør aldri arbeid på systemet, eller koble kabler til eller fra systemet når det tordner eller lyner.</b>
<b>Aviso</b>	<b>Não trabalhe no sistema ou ligue e desligue cabos durante períodos de mau tempo (trovoada).</b>
<b>¡Advertencia!</b>	<b>No operar el sistema ni conectar o desconectar cables durante el transcurso de descargas eléctricas en la atmósfera.</b>
<b>Varning!</b>	<b>Vid åska skall du aldrig utföra arbete på systemet eller ansluta eller koppla loss kablar.</b>
<b>Varning!</b>	<b>Vid åska skall du aldrig utföra arbete på systemet eller ansluta eller koppla loss kablar.</b>
<b>Figyelem</b>	<b>Villámlás közben ne dolgozzon a rendszeren, valamint ne csatlakoztasson és ne húzzon ki kábeleket!</b>
<b>Предупреждение</b>	Не следует работать с устройством, а также подключать или отключать кабели во время грозы.
<b>警告</b>	请勿在发生雷电时操作系统，也不要在此期间连接或断开电缆。

# Power and Relay Connector

**Warning**

When you connect or disconnect the power and relay connector with power applied, an electrical arc can occur. This could cause an explosion in hazardous area installations. Be sure that power is removed from the switch and alarm circuit. Be sure that power cannot be accidentally turned on or verify that the area is nonhazardous before proceeding.

Failure to securely tighten the power and relay connector captive screws can result in an electrical arc if the connector is accidentally removed. Statement 1058

**Waarschuwing**

Als u de aan-/uitschakelaar en relaisschakeling aanzet of uitschakelt met de stroom aan, kan er een lichtboog optreden. Dit kan leiden tot een explosie bij installaties in gevaarlijke gebieden. Zorg dat er geen stroom staat op het schakel- en alarmcircuit. Zorg dat de stroom niet per ongeluk kan worden aangezet en controleer of het gebied niet gevaarlijk is voordat u doorgaat.

Als de bevestigingsschroeven van de stroom- en relaisaansluiting niet goed zijn vastgedraaid, kan dit leiden tot een lichtboog als de aansluiting per ongeluk wordt verwijderd.

**Varoitus**

Virta- ja relekytkintä kytkettäessä tai irrotettaessa voi muodostua valokaari, jos virta on päällä. Tämä voi aiheuttaa räjähdysten vaarallisten alueiden asennuksissa. Varmista, että kytkimen ja hälyttimen piiristä on katkaistu virta. Varmista ennen jatkamista, ettei virtaa voida kytkeä vahingossa päälle tai ettei alue ole vaarallinen.

Jos virta- ja releliittimen lukkoruveja ei ole kiinnitetty tiukasti ja liitin irrotetaan vahingossa, seurauksena voi olla valokaari.

**Attention** Lorsque vous connectez ou déconnectez le connecteur alimentation et relais quand l'alimentation est allumée, un arc électrique risque de se produire. Un tel arc peut causer une explosion dans les installations en zones dangereuses. Assurez-vous de couper l'alimentation des circuits de commutation et d'alarme. Avant de continuer, assurez-vous également qu'il n'y a aucun risque de rebranchement accidentel de l'alimentation et que le site de travail ne présente pas de danger.

Si vous omettez de serrer à fond les vis imperdables du connecteur alimentation et relais, vous risquez de provoquer un arc électrique en cas de retrait accidentel du connecteur.

**Warnung** Wenn Sie den Stromzufuhr- und Relaisstecker anschließen oder herausziehen, während die Stromzufuhr eingeschaltet ist, kann sich ein elektrischer Bogen bilden. Dies kann bei Installationen in Gefahrenzonen zu einer Explosion führen. Überprüfen Sie, dass an Switch und Alarmschaltkreis kein Strom anliegt. Vergewissern Sie sich, dass die Stromzufuhr nicht versehentlich eingeschaltet werden kann, oder stellen Sie sicher, dass es sich beim gewählten Standort nicht um einen explosionsgefährdeten Bereich handelt, bevor Sie fortfahren.

Die unverlierbaren Schrauben am Stromversorgungs- und Relaisstecker müssen fest angezogen werden, da das versehentliche Herausziehen des Steckers zu einem elektrischen Bogen führen kann.

**Avvertenza** La connessione o disconnessione del connettore relè e di potenza con l'alimentazione inserita, può determinare la formazione di un arco elettrico. Ciò può causare un'esplosione in caso di installazioni in aree pericolose. Accertarsi di disinserire l'alimentazione dallo switch e dal circuito d'allarme. Prima di procedere, accertarsi che l'alimentazione non possa essere accidentalmente inserita o verificare che l'area non sia pericolosa.

Qualora non si serrassero perfettamente le viti prigioniere del connettore relè e di potenza, si potrebbe causare la formazione di un arco elettrico in caso di rimozione accidentale del connettore stesso.

- Advarsel** Hvis du tilkobler eller frakobler strømmen og relékoblingen mens strømmen er på, kan det oppstå en elektrisk bue. Dette kan danne en eksplosjon i installasjoner i farlige områder. Påse at strømmen fjernes fra bryteren og alarmkretsen. Påse at strømmen ikke slås på uforvarende eller kontrollerer at området er ufarlig før du fortsetter.
- Hvis de sikrete skruene på strøm- og relékoblingene ikke er forsvarlig tilskrudd, kan det føre til en elektrisk bue hvis koblingen fjernes uforvarende.
- Aviso** Ao conectar ou desconectar a alimentação e o conector de relé com a alimentação acionada, poderá ocorrer um arco elétrico. Isso pode causar uma explosão em instalações em áreas de risco. Certifique-se de que a alimentação do switch e do circuito de alarme foi interrompida. Certifique-se também de que não há possibilidade de a alimentação ser acionada acidentalmente ou verifique se a área é segura antes de prosseguir.
- Se os parafusos cativos do conector de relé e da alimentação não estiverem fixados firmemente, poderá ocorrer um arco elétrico no caso de remoção acidental do conector.
- ¡Advertencia!** Al conectar o desconectar el conector de relé y alimentación mientras se suministra alimentación, se puede crear un arco eléctrico que podría provocar una explosión en una zona de instalaciones peligrosas. Interrumpa el suministro de alimentación del switch y del circuito de alarma. Antes de continuar, asegúrese de que no se pueda volver a suministrar alimentación de forma accidental o compruebe que el área no sea peligrosa.
- Si no se aprietan suficientemente los tornillos cautivos del conector de relé y alimentación, se puede crear un arco eléctrico en caso de desconexión accidental del conector.
- Varning!** När du kopplar ström- och reläkontakten på och av med strømmen på, kan en elbåge uppstå. Detta kan orsaka en explosion på farliga installations områden. Se till att omkopplar- och larmkretsen inte är strömförande. Kontrollera att strømmen inte kan slås på oavsiktligt och verifiera att det inte finns några faromoment inom området innan du fortsätter.
- Underlåtelse att dra åt fästskruvarna på ström- och reläkontakten kan resultera i en elbåge om kontakten avlägsnas av misstag.

**Figyelem** Amikor a relés kapcsolót az elektromos hálózathoz csatlakoztatja, illetve ha megszakítja az áramot, elektromos ív jöhet létre. Ha a készülék veszélyes helyre van telepítve, ez robbanást okozhat. Győződjön meg róla, hogy a kapcsoló és a riasztó áramkör nincs feszültség alatt. Győződjön meg róla, hogy a készülék véletlenül nem kapcsolható be, és mielőtt továbblép, ellenőrizze, hogy a terület nem veszélyes-e.

Ha a tápkábel és a relés kapcsoló elveszthetetlen csavarjait nem rögzíti megfelelően, elektromos ív jöhet létre, ha a csatlakozót véletlenül eltávolítják.

**Предупреждение** При включении и отключении питания или разъема реле при включенном питании может возникнуть электрическая дуга. Это может привести к взрыву во взрывоопасной среде. Необходимо убедиться в том, что от переключателя и схемы сигнализации отключено электропитание. Также перед продолжением следует убедиться в том, что приняты меры, гарантирующие невозможность случайного включения электропитания, или в том, что окружающая среда не является взрывоопасной.

Если винты крепления разъемов питания и реле не будут надежно закреплены, то это может привести к случайному разъединению разъема и возникновению электрической дуги.

**警告** 当您在电源接通的情况下插拔电源和中继连接器时，可能会产生电弧。如果是在危险地区安装，就会引发爆炸。因此，应确保交换机和告警电路断开了电源。确保电源不会意外接通或确定该地区不存在危险，然后再安装。

若电源和中继连接器的紧固螺钉没有拧紧，则连接器意外断开时会产生电弧。

**警告** 通電状態にあるパワー/リレー コネクタを接続または切断する場合、電気アークが発生することがあります。電気アークは、危険な場所での設置の際に爆発を引き起こすことがあります。スイッチ/アラーム回路から電源が切断されていることを確認してください。偶発的に電源が入らないこと、または作業場所が危険でないことを確認してから作業を進めてください。

パワー/リレー コネクタの非脱落型ネジがしっかり締まっていないと、コネクタが外れてしまった場合に電気アークが発生することがあります。



# Switch Installation In Hazardous Location

**Warning**

In switch installations in a hazardous location, the DC power source could be located away from the vicinity of the switch. Before performing any of the following procedures, locate the DC circuit to ensure that the power is removed and cannot be turned on accidentally, or verify that the area is nonhazardous before proceeding. Statement 1059

**Waarschuwing**

Bij schakelinstallaties in een gevaarlijke locatie, mag de gelijkstroombron zich niet in de buurt van de schakelaar bevinden. Voordat u een van de volgende procedures uitvoert, dient u bij het gelijkstroomcircuit te controleren of de stroom is afgesloten en niet per ongeluk kan worden aangezet of dient u te controleren of het gebied niet gevaarlijk is voordat u doorgaat.

**Varoitus**

Kun kytkimen asennus tehdään vaaralliselle paikalle, tasavirtalähde voidaan sijoittaa pois kytkimen läheisyydestä. Ennen kuin suoritetaan mitään seuraavista toimista, etsi tasavirtapiiri ja varmista, että virta on katkaistu ja ettei sitä voida kytkeä vahingossa päälle, tai varmista ennen jatkamista, ettei alue ole vaarallinen.

**Attention**

Dans les installations commutées, si le site est dangereux, il est possible d'installer la source d'alimentation CC loin de l'interrupteur. Avant de réaliser l'une des procédures suivantes, identifiez le circuit CC pour vous assurer que l'alimentation est coupée et ne risque pas d'être rétablie par accident. Vérifiez que le site de travail ne présente aucun danger avant de continuer.

**Warnung**

Bei einer Switch-Installation in einem explosionsgefährdeten Gebiet, befindet sich die Gleichstromquelle evtl. nicht in unmittelbarer Nähe des Switches. Bevor Sie einen der folgenden Vorgänge ausführen, informieren Sie sich über den Standort der Gleichstromquelle, und vergewissern Sie sich, dass die Stromzufuhr unterbrochen ist und nicht versehentlich eingeschaltet werden kann, oder überprüfen Sie, dass es sich beim Standort nicht um ein explosionsgefährdetes Gebiet handelt.

- Avvertenza** In installazioni di switch in un'area pericolosa, la fonte di alimentazione CC potrebbe trovarsi distante dalla zona prossima allo switch. Prima di eseguire una delle procedure seguenti, individuare il circuito CC per assicurarsi che l'alimentazione sia disinserita e non possa essere accidentalmente inserita oppure verificare che l'area non sia pericolosa prima di procedere.
- Advarsel** I bryterinstallasjoner i et farlig område kan likestrømkilden plasseres i avstand fra bryteren. Før noen av de følgende prosedyrene utføres, må likestrømskretsen lokaliseres for å sikre at strømmen fjernes og ikke kan slås på uforvarende, eller kontrollere at området ikke er farlig før du fortsetter.
- Aviso** Em instalações de switches em um local de risco, a fonte de alimentação DC deve permanecer afastada do switch. Antes de executar qualquer um dos procedimentos a seguir, localize o circuito DC para garantir que a alimentação foi removida e não há possibilidade de ser acionada acidentalmente, ou verifique se a área é segura antes de prosseguir.
- ¡Advertencia!** En las instalaciones con switch que se encuentran en lugares peligrosos, la fuente de alimentación de CC debe estar alejada del switch. Antes de realizar ninguno de los siguientes procedimientos, localice el circuito de CC para asegurarse de que se ha interrumpido el suministro de alimentación y que no se puede volver a suministrar de forma accidental o compruebe que el área no es peligrosa antes de continuar.
- Varning!** Om strömbrytaren finns på en farlig plats, bör strömkällan (likström) finnas på ett visst avstånd från omkopplaren. Innan du utför någon följande rutiner, ska du lokalisera likströmskretsen för att försäkra dig om att den inte är strömförande och inte kan slå på oavsiktligt, samt verifiera att inga faromoment finns inom området innan du fortsätter.
- Figyelem** Ha a kapcsoló veszélyes helyre van telepítve, az egyenáramú tápforrást nem ajánlatos a kapcsoló közelébe helyezni. Mielőtt az alábbi lépésekhez hozzáférne, keresse meg az egyenáramú áramkört, és győződjön meg róla, hogy nincs feszültség alatt, illetve hogy nem kapcsolható be véletlenül. Mielőtt továbblép, azt is ellenőrizze, hogy a terület nem veszélyes-e.

- Предупреждение** При размещении переключателя во взрывоопасной среде источник питания постоянного тока может быть размещен на удалении от переключателя. Перед выполнением каких-либо описанных ниже действий следует найти цепь постоянного тока и убедиться в том, что питание отключено и не может быть случайно включено, или же в том, что окружающая среда не является взрывоопасной.
- 警告** 在危险的区域安装交换机时，直流电源应远离开关。在执行以下任何操作之前，应查找直流电路，确保电源已断开且不会意外接通，或确定该区域不存在危险，然后再安装。
- 警告** 危険な場所でスイッチを設置する際には、DC電源をスイッチ付近に置かないでください。以下の手順を実行する場合には、電源が切断され、偶発的に電源が入ることのないようDC回路を配置するか、あるいは作業場所が危険でないことを確認してから作業を進めてください。

## Safe Operating Voltage Range Warning



### Warning

**The nominal voltage for this product is 24 V. When the switch is installed in hazardous locations, the safe operating range of 18 to 32 VDC must be maintained.** Statement 1060

### Waarschuwing

**De nominale spanning voor dit product is 24 V. Als de schakelaar op een gevaarlijk locatie is geïnstalleerd, dient een veilig besturingsbereik van 18 tot 32 volt gelijkstroom te worden gehandhaafd.**

### Varoitus

**Tämän tuotteen nimellisjännite on 24 V. Kun kytkin on asennettu vaaralliseen paikkaan, on pidettävä yllä turvallinen 18-32 V:n tasavirtajännite.**

### Attention

**La tension minimale de ce produit est de 24 V. Si le commutateur est installé dans un site dangereux, il est nécessaire de maintenir une tension d'exploitation sécurisée de 18 à 32 VCC.**

■ Safe Operating Voltage Range Warning

<b>Warnung</b>	<b>Die Nominalspannung für dieses Produkt beträgt 24 V. Wenn der Switch in einer explosionsgefährdeten Zone installiert wird, muss zur Sicherheit stets eine Betriebsspannung von 18 bis 32 VDC eingehalten werden.</b>
<b>Avvertenza</b>	<b>La tensione nominale per questo prodotto è 24 V. Quando lo switch è installato in aree pericolose, è necessario mantenere un range operativo di sicurezza compreso tra 18 e 32 VCC.</b>
<b>Advarsel</b>	<b>Den nominelle spenningen for dette produktet er 24 V. Når bryteren er installert i farlige områder, må det trygge driftsområdet mellom 18 og 24 V likestrøm opprettholdes.</b>
<b>Aviso</b>	<b>A voltagem nominal deste produto é de 24V. Quando o switch for instalado em locais de risco, deve ser mantida a faixa de operação segura de 18 a 32 VDC.</b>
<b>¡Advertencia!</b>	<b>El voltaje nominal para este producto es de 24 V. Cuando el switch se instala en lugares peligrosos, se debe mantener el rango operativo de seguridad: entre 18 y 32 V CC.</b>
<b>Varning!</b>	<b>Den nominella spänningen för denna produkt är 24 V. När strömbrytaren installerats på farliga platser måste ett säkert driftspänning på 18 till 32 V likström upprätthållas.</b>
<b>Figyelem</b>	<b>A készülék névleges feszültsége 24 V. Ha a kapcsolót veszélyes helyre telepítik, a 18 – 32 V egyenáram közötti biztonságos működési tartományt be kell tartani.</b>
<b>Предупреждение</b>	<b>Номинальное напряжение для данного изделия – 24 В. При размещении переключателя во взрывоопасной среде необходимо, чтобы напряжение находилось в безопасном рабочем диапазоне от 18 до 32 В.</b>
<b>警告</b>	<b>此产品的额定电压为 24 伏。在危险地方安装本交换机时，必须维持 18 到 32 伏的直流电安全操作范围。</b>
<b>警告</b>	<b>この製品の公称電圧は、24 Vです。スイッチを危険な場所に設置する場合、許容動作範囲である18~32 VDCを維持してください。</b>

# Switch Relays Warning

**Warning**

The switch relays are rated at 1 Amp and have a voltage limit of 30 VDC and 0.3 Amp at a voltage limit of 125 VAC. It is dangerous to exceed these limitations in a hazardous environment.

An electrical arc can occur when you connect or disconnect the relay wires with field side power applied. This could cause an explosion in switch installations in a hazardous location. Before proceeding, be sure that power is removed or the area is not hazardous. Statement 1061

**Waarschuwing**

De schakelrelais van 1 ampère hebben een spanningslimiet van 30 volt gelijkstroom en 0,3 ampère bij een spanningslimiet van 125 volt wisselstroom. Het is riskant om deze beperkingen te overschrijden in een gevaarlijke omgeving.

Een lichtboog kan optreden als u de relaisdraden aansluit of ontkoppelt terwijl er stroom aan de kant van het alarmapparaat wordt toegepast. Dit kan leiden tot een explosie bij schakelinstallaties op een gevaarlijke locatie. Zorg dat de stroom is uitgeschakeld of het gebied niet gevaarlijk is voordat u doorgaat.

**Varoitus**

Kytkinreleiden luokitus on 1 A jänniterajan ollessa 30 VDC ja 0,3 A jänniterajan ollessa 125 VAC. Näiden rajojen ylittäminen on vaarallista vaarallisessa ympäristössä.

Relejohtoja kytkettäessä tai irrotettaessa voi muodostua valokaari, jos kenttäpuolen virta on päällä. Tämä voi aiheuttaa räjähdyksen, jos kytkin asennetaan vaaralliseen paikkaan. Varmista ennen jatkamista, että virta on katkaistu tai ettei alue ole vaarallinen.

## Switch Relays Warning

- Attention** Les relais à commutateur ont une intensité nominale d'un ampère (A) et une limitation de tension de 30 VCC (0,3 A à 125 VCA). Dans un environnement à risque, il est dangereux de dépasser ces limitations.
- Un arc électrique peut se produire lors de la connexion ou de la déconnexion des câbles de relais lorsque l'alimentation du côté terrain est activée. Si le site est dangereux, cela peut causer une explosion dans les installations commutées. Avant de continuer, vérifiez que l'alimentation est coupée et que le site ne présente aucun danger.
- Warnung** Die Switch-Relais haben eine Nennstromstärke von 1 A und eine Höchstspannung von 30 VDC bzw. eine Stromstärke von 0,3 A bei einer Höchstspannung von 125 VAC. In einem explosionsgefährdeten Gebiet sollten diese Werte aus Sicherheitsgründen nicht überschritten werden.
- Wenn Sie die Relaiskabel anschließen oder abnehmen, während die Stromzufuhr zum Alarmgerät eingeschaltet ist, kann sich ein elektrischer Bogen bilden. Dies kann bei Installation eines Switches in einer Gefahrenzone zu einer Explosion führen. Vergewissern Sie sich daher, bevor Sie fortfahren, dass die Stromzufuhr ausgeschaltet ist, oder es sich beim gewählten Standort nicht um ein explosionsgefährdetes Gebiet handelt.
- Avvertenza** I relè switch hanno una capacità nominale di 1 amp e una tensione limite di 30 VCC e capacità di 0,3 amp a una tensione limite di 125 VCA. È pericoloso superare questi limiti in un ambiente pericoloso.
- La connessione o disconnessione dei fili di relè con l'alimentazione lato campo inserita, può determinare la formazione di un arco elettrico. Ciò può causare un'esplosione in caso di installazioni di switch in aree pericolose. Prima di procedere, accertarsi che l'alimentazione sia disinserita o l'area non sia pericolosa.
- Advarsel** Bryterreléene er merket 1 A og har en spenningsgrense på 30 V likestrøm og 0,3 A med en spenningsgrense på 125 V likestrøm. Det medfører fare å overskride disse grensene i et farlig område.
- En elektrisk bue kan oppstå når du tilkobler eller frakobler relétråder med en strømførende ekstern alarmerhet. Dette kan forårsake eksplosjon i bryterinstallasjoner i farlige områder. Før du fortsetter må du være sikker på at strømmen er fjernet eller at området ikke er farlig.

- Aviso** Os relés do switch estão regulados para 1A e limite de voltagem de 30 VDC e 0,3A com limite de voltagem de 125 VAC. É perigoso exceder esses limites em um ambiente de risco.
- Pode ocorrer um arco elétrico se você conectar ou desconectar os cabos do relé com a alimentação de campo aplicada. Isso pode causar uma explosão em instalações de switches localizadas em um local de risco. Antes de prosseguir, confirme se a alimentação foi removida ou se a área é segura.
- ¡Advertencia!** Los relés del switch son de 1 amp y su límite de voltaje es de 30 V CC y 0,3 amp a un límite de voltaje de 125 V CA. Resulta peligroso superar estos límites en un entorno de riesgo.
- Al conectar o desconectar los cables del relé con suministro de alimentación, se puede crear un arco eléctrico que podría provocar una explosión en las instalaciones de switch que se encuentren en un lugar peligroso. Antes de continuar, asegúrese de que se ha interrumpido el suministro de alimentación o de que el área no es peligrosa.
- Varning!** Reläomkopplarna har märkvärdet 1 A och har en spänningsgräns på 30 V likström och 0,3 A med en spänningsgräns på 125 V växelström. Det är farligt att överskrida dessa begränsningar i en farlig miljö.
- En elbåge kan uppstå när du kopplar till eller från reläledningarna med fältsideffekt på. Detta kan leda till en explosion i omkopplarinstitutioner på en farlig plats. Innan du fortsätter ska du kontrollera att strömmen har slagits av och att platsen inte är farlig.
- Figyelem** A kapcsoló reléinek névleges árama 1 A, feszültségkorlátja 30 V egyenáram; 0,3 A esetén a feszültségkorlát 125 V egyenáram. Veszélyes környezetben kockázatos túllépni ezeket a határértékeket.
- Ha hálózati tápellátást használ, elektromos ív jöhet létre, amikor a relés kapcsolót az elektromos áramhoz csatlakoztatja, illetve ha megszakítja az áramot. Ha a kapcsoló veszélyes helyre van telepítve, ez robbanást okozhat. Mielőtt folytatná, győződjön meg róla, hogy a készülék nincs feszültség alatt, és hogy a terület nem veszélyes.

## Switch Relays Warning

### Предупреждение

Реле переключателя рассчитано на ток 1 А при напряжении не выше 30 В постоянного тока и 0,3 А при напряжении не выше 125 В переменного тока. Превышение данных предельных значений во взрывоопасной среде опасно.

При подключении или отключении проводов реле с включенным напряжением питания может возникнуть электрическая дуга. Это может привести к взрыву при размещении переключателя во взрывоопасной среде. Перед продолжением следует убедиться в том, что питание отключено или окружающая среда не является взрывоопасной.

### 警告

交换机中继器的额定电流强度为：在 30 伏的直流电压限制下为 1 安培；在 125 伏的交流电压限制下为 0.3 安培。在危险的环境中，超过这些限制是危险的。

当您在操作现场的电源接通的情况下插拔中继器的电线时，可能会产生电弧。如果是在危险的地方安装交换机，这会引发爆炸。因此，安装之前，应确保电源已断开或该区域没有危险。

### 警告

スイッチリレーの定格は1 Aであり、電圧制限は30 VDCです。また、125 VACの電圧制限では0.3 Aです。危険性の高い環境でこの制限を越えると危険です。

フィールド側が通電している状態でリレー線を接続または切断すると、電気アークが発生することがあります。電気アークは、危険な場所でスイッチを設置する際に爆発を引き起こすことがあります。電源が切断されているか、あるいは作業場所が危険でないことを確認してから作業を進めてください。



# Remove Power Before Disconnecting

**Warning**

**Do not disconnect connections to this equipment unless power has been removed or you have verified that the area is nonhazardous. Secure any external connections that mate to this equipment by using screws, sliding latches, threaded connectors, or other means provided with this product.**

**Substitution of components may impair suitability for Class I, Division 2.**  
Statement 1062

**Waarschuwing**

**Ontkoppel geen aansluitingen naar deze apparatuur tenzij de stroom is uitgeschakeld of u hebt gecontroleerd of het gebied niet gevaarlijk is. Bevestig externe aansluitingen die bij deze apparatuur horen m.b.v. de schroeven, schuifvergrendelingen, draadaansluitingen of andere middelen die bij dit product werden geleverd.**

**Vervanging van onderdelen kan van negatieve invloed zijn op de geschiktheid voor klasse I, divisie 2.**

**Varoitus**

**Tähän laitteeseen tulevia kytkentöjä ei saa kytkeä irti, jos virtaa ei ole katkaistu tai jos alueen vaarattomuutta ei ole varmistettu. Kiinnitä kaikki tähän laitteeseen tulevat ulkoiset liitännät ruuveilla, liukusalvoilla, kierteisillä liittimillä tai muilla tämän tuotteen mukana toimitetuilla keinoilla.**

**Osien korvaaminen voi heikentää luokan I, ryhmän 2 (Class I, Division 2) mukaista sopivuutta.**

**Attention**

**Déconnectez les câbles de cet équipement uniquement si l'alimentation est désactivée et si le site est sans danger. Fixez bien toutes les connexions externes qui se rattachent à cet équipement à l'aide de vis, de verrous à glissière, de connecteurs filetés ou d'autres dispositifs fournis avec ce produit.**

**Toute substitution de composant est susceptible de rendre le produit incompatible avec les normes de Classe I, Division 2.**

**Remove Power Before Disconnecting**

**Warnung** Verbindungen zum Gerät sollten nicht hergestellt bzw. unterbrochen werden, bevor die Stromzufuhr ausgeschaltet wurde, oder Sie sich davon überzeugt haben, dass es sich beim gewählten Standort nicht um ein explosionsgefährdetes Gebiet handelt. Sichern Sie alle externen Verbindungen zum Gerät durch Schrauben, Führungsriegel, Konnektoren mit Schraubgewinde oder andere Hilfsmittel, die im Produktlieferungsumfang enthalten sind.

Ein Austausch von Komponenten kann dazu führen, dass das Produkt nicht mehr den Bestimmungen von Klasse 1, Abteilung 2 entspricht.

**Avvertenza** Non disconnettere le connessioni a quest'apparecchiatura a meno che non sia stata disinserita l'alimentazione o non si sia verificato che l'area non è pericolosa. Fissare eventuali connessioni esterne afferenti a quest'apparecchiatura usando viti, ganci scorrevoli, connettori filettati o altri dispositivi forniti insieme a questo prodotto.

La sostituzione di componenti può compromettere l'idoneità alla Classe I, Divisione 2.

**Advarsel** Koblingene til dette utstyret må ikke frakobles med mindre strømmen er fjernet eller du har kontrollert at området ikke er farlig. Eventuelle eksterne koblinger som tilkobles dette utstyret med skruer, skyvelås, gjengete koblinger eller annet utstyr som leveres med dette produktet, må sikres.

Utskiftning av komponenter kan svekke egnetheten for klasse 1, seksjon 2.

**Aviso** Não desconecte as conexões deste equipamento a menos que a alimentação tenha sido cortada ou caso você tenha confirmado que a área é segura. Fixe quaisquer conexões externas ligadas a este equipamento usando parafusos, travas, conectores de rosca ou outros meios fornecidos com este produto.

A substituição de componentes pode prejudicar a compatibilidade com a Classe I, Divisão 2.

**¡Advertencia!** **No desconecte las conexiones de este equipo a menos que se haya interrumpido el suministro de alimentación o haya comprobado que el área no es peligrosa. Proteja todas las conexiones externas que se conectan al equipo mediante tornillos, pestillos deslizantes, conectores de rosca u otros sistemas que se hayan proporcionado con este producto.**

**La sustitución de componentes puede anular su idoneidad como dispositivo de la Clase I, División 2.**

**Varning!** **Koppla inte från denna utrustning om inte elanslutningen har avlägsnats eller du har verifierat att området inte är farligt. Sätt fast alla externa anslutningar till denna utrustning med skruvar, haspar, gängade kontaktdon, eller på något annat sätt som tillhandahållas med produkten.**

**Om komponenterna substitueras kan detta påverka enhetens lämplighet för Klass I, Division 2.**

**Figyelem** **A készüléket csak akkor csatlakoztassa, ha nincs feszültség alatt, vagy meggyőződött róla, hogy a terület nem veszélyes. A készülékhez csatlakozó külső elemeket csavarokkal, kapcsokkal, menetes csatlakozókkal vagy a készülékhez mellékelt más eszközökkel csatlakoztassa.**

**Ha másfajta eszközöket használ, lehet, hogy a készülék elveszíti Class I, Division 2 minősítését.**

**Предупреждение** **Не отключайте подключенные к данному оборудованию провода, пока не убедитесь, что питание отключено или окружающая среда не является взрывоопасной. Закрепите все внешние соединения в цепях, подключаемых к данному оборудованию, с помощью винтов, выдвижных защелок, резьбовых соединений или других приспособлений, поставляемых вместе с данным оборудованием.**

**Замена компонентов может привести к возникновению несоответствия стандарту класса I, подразделу 2.**

## “Open Type” Equipment

**警告** 除非电源已经断开或者已确定该区域没有危险，否则不要断开与本设备的连接。使用随本产品提供的螺钉、滑栓、螺纹连接器或其它零件，牢牢固定此设备与外部的连接。

若更换部件，可能影响 I 级 2 区的适用性。

**警告** 電源が切断されているか、あるいは作業場所が危険でないことが確認された場合以外、この装置の接続を取り外さないでください。ネジ、スライド式ラッチ、ネジ付きコネクタ、またはこの製品に付いているその他の手段により、この装置に取り付けるあらゆる外部接続をしっかりと固定してください。

代替部品の使用により、Class I Division 2に適合しなくなることがあります。

# “Open Type” Equipment



## Warning

**This equipment is supplied as “open type” equipment. It must be mounted within an enclosure that is suitably designed for those specific environmental conditions that will be present and appropriately designed to prevent personal injury resulting from accessibility to live parts. The interior of the enclosure must be accessible only by the use of a tool.**

**The enclosure must meet IP 54 or NEMA type 4 minimum enclosure rating standards.** Statement 1063

## Waarschuwing

**Deze apparatuur wordt geleverd als open apparatuur. De apparatuur dient in een kast gemonteerd te worden die ontworpen is om te voldoen aan de specifieke omgevingscondities die aanwezig zijn en om persoonlijk letsel te vermijden dat kan voorkomen als actieve onderdelen gemakkelijk toegankelijk zijn. De binnenkant van de kast mag alleen toegankelijk zijn d.m.v. een gereedschap.**

**De kast dient minimaal te voldoen aan de IP 54-normen of de minimale normen voor NEMA type 4.**

- Varoitus** Tämä laite toimitetaan tyypiltään "avoimena" laitteena. Se täytyy kiinnittää sellaisen kotelon sisään, joka soveltuu kyseeseen tuleviin ympäristöolosuhteisiin ja on valmistettu siten, että voidaan välttää jännitteellisiin osiin pääsemisen aiheuttamat tapaturmat. Koteloinnin sisään saa päästä ainoastaan työkalun avulla.
- Kotelon on oltava kotelointiluokituksen IP 54 tai NEMA tyyppi 4 mukainen.**
- Attention** Cet équipement est fourni « non protégé ». Il doit être monté dans une armoire adaptée aux conditions ambiantes spécifiques lors de l'installation et conçue pour prévenir les lésions corporelles résultant de l'accessibilité aux pièces sous tension. L'intérieur de l'armoire doit n'être accessible qu'à l'aide d'un outil.
- L'armoire doit répondre aux normes IP 54 ou NEMA type 4.**
- Warnung** Dieses Gerät wird als Gerät „offenen Typs“ geliefert. Es muss in ein Gehäuse eingebaut werden, dass für die spezifischen Standortbedingungen geeignet ist, und muss so konstruiert sein, dass Personenschäden aufgrund eines Kontakts mit dem Gerät bzw. Gehäuseinneren ausgeschlossen ist. Das Innere des Gehäuses darf nur durch Einsatz von Werkzeug zu öffnen sein.
- Das Gehäuse muss den Minimalanforderungen für Gehäuse gemäß IP 54 oder NEMA Typ 4 entsprechen.**
- Avvertenza** Quest'apparecchiatura è classificata di "tipo aperto". Deve essere montata in una struttura adeguatamente progettata per le condizioni ambientali specifiche in cui verrà utilizzata e allo scopo di prevenire lesioni personali derivanti dall'accesso a parti sotto tensione. La parte interna della struttura deve essere accessibile soltanto con l'ausilio di uno strumento.
- La struttura deve essere conforme alle norme di capacità minima strutturale IP 54 o NEMA di tipo 4.**

■ "Open Type" Equipment

- Advarsel** Dette utstyret leveres som "åpen type"-utstyr. Det må monteres i et avgrenset område som er utformet for de spesielle miljøforholdene som finnes og designet for å hindre personlig skade som kan oppstå ved å ha tilgang til strømførende deler. De indre delene av det avgrensede området må bare være tilgjengelige ved hjelp av verktøyer.
- Det avgrensede området må tilfredsstille minimum-standardene IP 54 eller NEMA type 4 for avgrensede områder.
- Aviso** Este equipamento é fornecido como um equipamento de "tipo aberto". Ele deve ser montado em um gabinete apropriado às condições ambientais específicas que estarão presentes e projetado para evitar ferimentos que possam ser causados às pessoas quando estas tentarem acessar suas peças. O acesso ao interior do gabinete deve ser feito somente com o uso de uma ferramenta.
- O gabinete deve atender aos padrões mínimos IP 54 ou NEMA tipo 4 de classificação de gabinetes.
- ¡Advertencia!** Este equipo se proporciona como equipo de "tipo abierto". Se debe montar en un alojamiento diseñado específicamente para las condiciones ambientales concretas que estarán presentes y para evitar daños personales al acceder a las partes en movimiento. La parte interior del alojamiento sólo debe poder abrirse mediante una herramienta.
- Dicho alojamiento debe cumplir los estándares mínimos para alojamientos IP 54 o NEMA tipo 4.
- Varning!** Denna utrustning levereras som utrustning av "öppen typ". Den måste monteras inom ett hölje som är konstruerat för de särskilda miljöförhållanden som kommer att uppstå och för att förhindra personskador som följd av kontakt med strömförande komponenter. Enheten måste konstrueras så att man endast kan få åtkomst till höljets inre med hjälp av verktyg.
- Höljet måste uppfylla minimistandarderna för höljen enligt IP 54 eller NEMA typ 4.

**Figyelem** A készülék „nyílt típusú” készülék. A készüléket olyan házba kell beszerelni, amely megfelel a környezeti viszonyoknak és megakadályozza, hogy a feszültség alatt lévő alkatrészekhez bárki is hozzáférjen és emiatt megsérüljön. A ház belsejéhez csak eszköz segítségével szabad tudni hozzáférni.

A háznak meg kell felelnie az IP 54 vagy a NEMA type 4 minimális követelményeknek.

**Предупреждение** Данное оборудование относится к «открытому типу». Оно должно монтироваться внутри корпуса, рассчитанного на определенные условия окружающей среды, в которых предполагается его эксплуатация, а также обеспечивающего защиту персонала от травм путем ограничения доступа к внутренним рабочим частям. Доступ к внутренним частям корпуса должен обеспечиваться только с помощью специальных инструментов.

Корпус должен соответствовать минимальным требованиям стандарта IP 54 или NEMA типа 4.

**警告** 此设备为“开式”设备。它必须安装在经过专门设计，符合上述特定环境要求的封闭罩中，使人们无法接触到那些带电的部件，从而可避免人员伤害。这个封闭罩的内部只有使用工具才能伸进去。

此封闭罩必须符合 IP 54 或 NEMA 4 类最低额定封闭标准。

**警告** この装置は「オープン タイプ」装置として提供されます。この装置は、設置場所の環境条件に適合するよう適切に設計され、また充電部への可触性により生ずる怪我を防ぐよう適切に設計された格納ラック内に設置してください。格納ラック内部の操作は、必ず工具を使用して行ってください。

この格納ラックは、IP 54またはNEMA type 4の最小限の格納ラック定格標準を満たしている必要があります。

# Grounded Equipment



## Warning

This equipment is intended to be grounded to comply with emission and immunity requirements. Ensure that the switch functional ground lug is connected to earth ground during normal use. Statement 1064

## Waarschuwing

Deze apparatuur dient geaard te worden in overeenstemming met emissie- en immuñiteitsvereisten. Zorg dat de functionele verbindingsstrip van de schakelaar geaard is tijdens normaal gebruik.

## Varoitus

Tämä laite on tarkoitettu maadoitettavaksi säteily- ja häiriönsietovaatimusten täyttämiseksi. Varmista, että kytkimen toiminnallinen maadoituskenkä on kytketty maadoitukseen normaalikäytön aikana.

## Attention

Cet équipement doit être relié à la terre pour répondre aux exigences en matière d'émissions et d'immunité. Vérifiez que la vis de mise à la terre fonctionnelle du commutateur est bien connectée à la terre pendant l'exploitation de l'équipement.

## Warnung

Dieses Gerät muss geerdet werden, um den Strahlungs- und Störfestigkeitsbestimmungen zu entsprechen. Stellen Sie daher sicher, dass während des normalen Betriebs die Massenanschlussöse des Switches mit dem Erdleiter verbunden ist.

## Avvertenza

Quest'apparecchiatura deve essere collegata a terra al fine di essere conforme ai requisiti di emissione e immunità. Assicurarsi che il terminale di terra funzionale dello switch sia collegato a massa durante l'uso normale.

## Advarsel

Dette utstyret er beregnet på jording som samsvarer med kravene til utslipp og immunitet. Påse at bryterens funksjonelle jordingskabelsko er koblet til jording ved normal bruk.

## Aviso

Este equipamento deve ser aterrado para atender aos requisitos de emissão e imunidade. Certifique-se de que o suporte de aterramento funcional do switch esteja conectado ao terra durante a operação normal.



- ¡Advertencia!** Este equipo está diseñado para que se conecte a tierra de modo que cumpla con los requisitos de emisión e inmunidad. Asegúrese de que el terminal de tierra funcional del switch está conectado a tierra durante el uso normal.
- Varning!** Denna utrustning bör jordas för att uppfylla gällande emissions- och immunitetskrav. Se till att omkopplarens funktionella jordningsfläns är jordad under normal användning.
- Figyelem** A készüléket védőföldeléssel kell ellátni, hogy megfeleljen a kibocsátásra és a védeettségre vonatkozó követelményeknek. Győződjön meg róla, hogy a kapcsoló földelősaruja normál használat során csatlakozik a földhöz.
- Предупреждение** Данное оборудование рассчитано на использование заземления для соответствия требованиям по уровню собственного излучения и устойчивости к внешним излучениям. Убедитесь, что во время эксплуатации монтажный лепесток заземления переключателя подключен к заземляющему проводу.
- 警告** 此设备应当接地，以满足防辐射和抗干扰的要求。在正常使用期间，请确保交换机上的接地端子良好接地。
- 警告** この装置は、放射イミュニティ要件に適合するようにアースされていることが前提になっています。通常の使用時には、スイッチのアースラグが確実に接地されているようにしてください。

# Console Cable Connection



## Warning

If you connect or disconnect the console cable with power applied to the switch or any device on the network, an electrical arc can occur. This could cause an explosion in hazardous location installations. Be sure that power is removed or the area is nonhazardous before proceeding.

To verify switch operation, perform **POST** on the switch in a nonhazardous location before installation. Statement 1065

## Waarschuwing

Als u de consolekabel aansluit of ontkoppelt terwijl er stroom op de schakelaar of op een ander apparaat op het netwerk staat, kan er een lichtboog optreden. Dit kan leiden tot een explosie bij installaties in gevaarlijke gebieden. Zorg dat de stroom is uitgeschakeld of controleer of het gebied niet gevaarlijk is voordat u doorgaat.

Om de schakeloperatie te controleren, voert u vóór de installatie een **POST** (power-on self test) uit op de schakelaar in een niet gevaarlijke omgeving.

## Varoitus

Jos konsolikaapeli kytketään tai irrotetaan virran ollessa kytkettynä kytkimeen tai muuhun verkossa olevaan laitteeseen, voi muodostua valokaari. Tämä voi aiheuttaa räjähdysten vaarallisten paikkojen asennuksissa. Varmista ennen jatkamista, että virta on katkaistu tai että alue on vaaraton.

Varmista kytkimen toiminta suorittamalla kytkimelle **POST** vaarattomassa paikassa ennen asennusta.

## Attention

Lors de la connexion ou de la déconnexion du câble de la console, un arc électrique risque de se produire lors de l'application de l'alimentation au commutateur ou à tout périphérique connecté au réseau. Si le site est dangereux, cela peut causer une explosion dans les installations commutées. Avant de continuer, vérifiez que l'alimentation est coupée et que le site ne présente aucun danger.

Pour vérifier la commande du commutateur, procédez à un essai de ce dernier, avant installation et dans un site sans danger.

- Warnung** Wenn die Konsolenkabel angeschlossen bzw. abgenommen werden, während die Stromzufuhr zum Switch oder einem beliebigen anderen Gerät im Netzwerk eingeschaltet ist, kann sich ein elektrischer Bogen bilden. Dies kann bei Installationen in Gefahrenzonen zu einer Explosion führen. Vergewissern Sie sich daher, bevor Sie fortfahren, dass die Stromzufuhr ausgeschaltet ist, oder es sich beim gewählten Standort nicht um ein explosionsgefährdetes Gebiet handelt.
- Um den korrekten Betrieb des Switches zu überprüfen, führen Sie vor der Installation in einer nicht-explosionsgefährdeten Umgebung einen Produktselbsttest (POST) durch.
- Avvertenza** La connessione o disconnessione del cavo della console con l'alimentazione inserita allo switch o qualsiasi dispositivo in rete, può determinare la formazione di un arco elettrico. Ciò può causare un'esplosione in caso di installazioni in aree pericolose. Prima di procedere, accertarsi che l'alimentazione sia disinserita o l'area non sia pericolosa.
- Per verificare il funzionamento dello switch, eseguire POST sullo switch in un'area non pericolosa prima dell'installazione.
- Advarsel** Hvis du tilkobler eller frakobler konsollkabelen med strømtilførsel til bryteren eller andre deler av nettet, kan det oppstå en elektrisk bue. Dette kan forårsake eksplosjon i installasjoner i farlige områder. Påse at strømmen er fjernet eller at området ikke er farlig før du fortsetter.
- Kontroll av bryterdriften foretas ved å utføre POST (selvtest når strømmen slås på) på bryteren i et ikke-farlig område før installasjonen.
- Aviso** Se você conectar ou desconectar o cabo do console com a alimentação sendo fornecida ao switch ou a qualquer dispositivo da rede, poderá ocorrer um arco elétrico. Isso pode causar uma explosão em instalações em áreas de risco. Antes de prosseguir, confirme se a alimentação foi removida ou se a área é segura.
- Para verificar o funcionamento do switch, execute um POST nele em uma área segura antes da instalação.

**¡Advertencia!** Si conecta o desconecta el cable de la consola al switch o a cualquier dispositivo de la red mientras se suministra alimentación, se puede crear un arco eléctrico que podría provocar una explosión en una zona de instalaciones peligrosas. Antes de continuar, asegúrese de que se ha interrumpido el suministro de alimentación o de que el área no es peligrosa.

Para comprobar el funcionamiento del switch, realice las pruebas iniciales (POST) del switch en un lugar que no sea peligroso antes de la instalación.

**Varning!** Om du ansluter eller kopplar loss konsolkabeln medan strömmen är kopplad till omkopplaren eller någon anordning inom nätverket, kan en elbåge uppstå. Detta kan orsaka en explosion på farliga installationsplatser. Innan du fortsätter ska du kontrollera att strömmen har slagits av och att platsen inte är farlig.

För att verifiera omkopplarens funktions, ska du utföra POST på omkopplaren på en icke farlig plats före installationen.

**Figyelem** Ha csatlakoztatja vagy kihúzza a konzolkábelt, elektromos ív jöhet létre, ha a kapcsoló vagy a hálózatban lévő bármely eszköz feszültség alatt van. Ha a készülék veszélyes helyre van telepítve, ez robbanást okozhat. Mielőtt folytatná, győződjön meg róla, hogy a készülék nincs feszültség alatt, és hogy a terület nem veszélyes.

A kapcsoló működésének ellenőrzéséhez a telepítés előtt végezzen POST tesztelést egy nem veszélyes helyen.

**Предупреждение** При подключении и отключении кабеля консоли с поданным на переключатель или какое-либо другое устройство в цепи напряжением питания может возникнуть электрическая дуга. Это может привести к взрыву во взрывоопасной среде. Перед продолжением следует убедиться в том, что питание отключено или окружающая среда не является взрывоопасной.

Чтобы убедиться в правильности работы переключателя, перед его монтажом произведите его проверку в безопасном месте.

**警告** 如果在交换机或网上任一设备的电源接通的情况下插拔控制台电缆，会产生电弧。如果是在危险的地方安装，就会引发爆炸。因此，安装之前，应确保电源已断开或该地区没有危险。

要检查交换机的运转情况，应在安装前，在没有危险的地方，执行交换机的通电自检 (POST)。

**警告** スイッチまたはネットワーク上の装置が通電している状態でコンソール ケーブルを接続または切断すると電気アークが発生することがあります。電気アークは、危険な場所での設置の際に爆発を引き起こすことがあります。電源が切断されているか、あるいは作業場所が危険でないことを確認してから作業を進めてください。

スイッチ動作を確認するには、設置する前に危険がない場所でスイッチの POST を実行します。

## Overtemperature Warning



### Warning

**To prevent the switch from overheating, do not operate it in an area that exceeds the maximum recommended ambient temperature of 140°F (60°C). To prevent airflow restriction, allow at least 3 inches (7.6 cm) of clearance around the ventilation openings.** Statement 17C

### Waarschuwing

**Om te voorkomen dat de schakelaar oververhit raakt, dient u deze niet te gebruiken in een ruimte waar de aanbevolen maximale omgevingstemperatuur van 60°C wordt overschreden. Laat minstens 7,6 cm speling rond de ventilatieopeningen om blokkering van de luchtstroom te voorkomen.**

### Varoitus

**Jotta kytkin ei kuumentuisi liikaa, sitä ei saa käyttää alueella, jonka lämpötila on suurempi kuin suurin suositeltu käyttöympäristön lämpötila 60 °C. Ilmanvaihtoaukkojen ympärillä on oltava vähintään 7,6 cm tyhjää tilaa, jotta ilmanvirtaus ei esty.**

**Overtemperature Warning**

- Attention** Pour éviter toute surchauffe du système, il est recommandé de maintenir une température ambiante inférieure à 60°C. Pour assurer une aération suffisante, ménagez un espace d'au moins 7,6 cm autour des aérats.
- Warnung** Um den Switch vor Überhitzung zu schützen, vermeiden Sie dessen Betrieb in einer Umgebung, in der das empfohlene Maximum von 60° C überschritten wird. Sorgen Sie dafür, dass um die Lüftungsöffnungen ein Abstand von mindestens 8 cm eingehalten wird, damit eine ausreichende Luftzirkulation gewährleistet ist.
- Avvertenza** Per evitare il surriscaldamento dello switch, non utilizzarlo in un'area la cui temperatura ambiente superi il valore massimo raccomandato di 60°C. Per evitare limitazioni alla circolazione dell'aria, lasciare uno spazio libero di almeno 7,6 cm intorno alle aperture di ventilazione.
- Advarsel** For å hindre at bryteren blir overopphetet, skal den ikke brukes i et område som overstiger maksimum anbefalt omgivelsestemperatur på 60 °C. For å hindre luftstrømbegrensninger, må det være minst 7,6 cm klaring rundt ventilåpningene.
- Aviso** Para evitar o superaquecimento do switch, não o opere em áreas que excedam a temperatura ambiente máxima recomendada de 140°F (60°C). Para evitar a obstrução do fluxo de ar, deixe um espaço de pelo menos 3 polegadas (7,6 cm) junto às aberturas de ventilação.
- ¡Advertencia!** Para impedir que el sistema se recaliente, no lo utilice en zonas en las que la temperatura ambiente supere la temperatura máxima recomendada de 60°C (140°F). Para evitar obstrucciones del flujo de aire, deje un espacio libre mínimo de 7,6 cm (3 pulg.) alrededor de las ranuras de ventilación.
- Varning!** I syfte att undvika överhettning av switchen skall den inte användas i utrymmen vars temperatur överskrider den maximalt rekommenderade omgivningstemperaturen som är 60 °C. Kontrollera att det finns minst 7,6 cm fritt utrymme runt ventilationsöppningarna så att luftflödet inte begränsas.
- Figyelem** A túlmelegedés megelőzése végett ne üzemeltesse a kapcsolót olyan területen, ahol a hőmérséklet meghaladja a 60°C maximális ajánlott környezeti hőmérsékletet. A megfelelő légáramlás biztosítása érdekében a szellőzőnyílások körül hagyjon szabadon legalább 7,6 cm helyet.

- Предупреждение** Во избежание перегрева переключателя его не следует использовать в помещениях, в которых температура воздуха выше максимальной рекомендованной: 140°F (60°C). Во избежание ограничения воздушного потока около вентиляционных отверстий должно быть не менее 3 дюймов (7,6 см) свободного пространства.
- 警告** 为防止交换机过热，不要在周围环境超过建议的最高温度 140°F (60°C) 的地区运行该系统。为防止气流不畅，通风口周围至少要有 3 英寸 (7.6 厘米) 的净空。
- 警告** スイッチの過熱を防ぐため、推奨最高周囲温度140°F (60°C) を超える場所ではスイッチを稼働させないでください。通気が妨げられないように、通気口の周囲に3インチ (7.6 cm) 以上のスペースを確保してください。

## Class I, Division 2, Hazardous Location



### Warning

**When used in a Class I, Division 2, hazardous location, this equipment must be mounted in a suitable enclosure with proper wiring method, for all power, input and output wiring, that complies with the governing electrical codes and in accordance with the authority having jurisdiction over Class I, Division 2 installations.** Statement 1066

### Waarschuwing

**Als de apparatuur wordt gebruikt in een gevaarlijke omgeving van de klasse I, divisie 2, dient deze geïnstalleerd te worden in een daarvoor bestemde kast met de juiste bedradingsmethode voor alle stroom-, ingangs- en uitgangsbedrading, die voldoet aan de elektrische bouwverordeningen en in overeenstemming is met de instantie die gaat over installaties van klasse I, divisie 2.**

<b>Varoitus</b>	<b>Kun tätä laitetta käytetään luokan I, ryhmän 2 (Class I, Division 2) mukaisessa vaarallisessa paikassa, se täytyy kiinnittää sopivaan koteloon asianmukaisella johdotusmenetelmällä kaikkien virta-, tulo- ja lähtöjohtojen osalta. Käytetyn menetelmän on oltava asiasta määräävien sähkösäännösten mukainen ja noudatettava luokan I, ryhmän 2 asennuksista vastaavien viranomaisten määräyksiä.</b>
<b>Attention</b>	<b>Lorsqu'il est utilisé dans un site de la Classe I, Division 2, cet équipement doit être monté dans une armoire appropriée avec câblage suffisant pour tout type de câble d'entrée et de sortie, conforme aux codes électriques en vigueur et avec l'autorité ayant juridiction sur les installations de la Classe I, Division 2.</b>
<b>Warnung</b>	<b>Bei Einsatz in einem explosionsgefährdeten Gebiet gemäß Klasse 1, Abteilung 2, muss das Gerät in ein geeignetes Gehäuse eingebaut werden, und für alle Strom-, Eingangs- und Ausgangskabel muss eine geeignete Verkabelungsmethode gewählt werden, die den gültigen elektrischen Sicherheitsbestimmungen sowie den Anforderungen der für Klasse 1, Abteilung 2 zuständigen Behörden entsprechen.</b>
<b>Avvertenza</b>	<b>Allorché usata in un'area pericolosa di Classe I, Divisione 2, quest'apparecchiatura deve essere montata in una struttura adatta con un metodo di cablaggio appropriato per le linee di alimentazione, entrata e uscita, che sia conforme alle norme elettriche vigenti e in osservanza all'autorità avente giurisdizione sulle installazioni di Classe I, Divisione 2.</b>
<b>Advarsel</b>	<b>Når dette utstyret brukes i et farlig område i klasse I, seksjon 2, må det monteres i et egnet avgrenset område med korrekt ledningsopplegg for all strøm, inngangs- og utgangskabler som samsvarer med gjeldende elektriske koder og i henhold til fagfolk som har kompetanse for klasse 1, seksjon 2-installasjoner.</b>
<b>Aviso</b>	<b>Quando utilizado em um local de risco de Classe I, Divisão 2, este equipamento deve ser montado em um gabinete apropriado com o cabeamento adequado para toda a alimentação e cabeamento de entrada e saída, sendo estes compatíveis com os códigos elétricos vigentes e de acordo com a autoridade que regula instalações de Classe I, Divisão 2.</b>



- ¡Advertencia!** Si se utiliza en una ubicación peligrosa de Clase I, División 2, el equipo debe montarse en un alojamiento adecuado con el sistema de cableado correspondiente, tanto de entrada como de salida, que cumpla los códigos eléctricos vigentes y las normativas de la autoridad que tenga jurisdicción sobre las instalaciones de Clase I, División 2.
- Varning!** När utrustningen används på en plats, som klassificerats som Klass I, Division 2, måste den monteras i ett lämpligt hölje med korrekt ledningsdragningsmetod för alla el-, ingångs- och utgångsledningar, som uppfyller gällande elföreskrifter och i enlighet med de krav som utfärdats av organ som har jurisdiktion över installationer som tillhör Klass I, Division 2.
- Figyelem** Ha a készüléket Class I, Division 2 minősítésű helyen használja, a készüléket olyan házba kell beszerezni, és úgy kell mind a bemeneti, mind a kimeneti vezetékeztést elkészíteni, hogy az megfeleljen az elektromos előírásoknak, valamint a Class I, Division 2 rendszereket felügyelő hivatal követelményeinek.
- Предупреждение** При эксплуатации в условиях опасной окружающей среды в соответствии с требованиями класса I, подраздела 2, данное оборудование должно быть размещено в соответствующем корпусе с надлежащим электрическим монтажом всех цепей питания, входных цепей и выходных цепей, соответствующим нормативным требованиям к электрооборудованию и выполненным лицами, уполномоченными на монтаж оборудования класса I, подраздела 2.
- 警告** 在Ⅰ级Ⅱ区危险地带使用时，该设备必须安装在适当的封闭罩中，所有电源（输入输出线）都应有正确的布线方式，即：遵守相关的用电法规，服从有关部门对在Ⅰ级Ⅱ区地带安装的规定。
- 警告** この装置をClass I Division 2の危険な場所で使用する場合には、正しい配線方法で、適切な格納ラックに設置してください。正しい配線方法とは、すべての電源配線および入出力配線が、適用電気規約に適合し、Class I Division 2設置の管轄当局に従っているものです。

# Twisted-pair Supply Wires



## Warning

**Use twisted-pair supply wires suitable for 86°F (30°C) above surrounding ambient temperature outside the enclosure.** Statement 1067

## Waarschuwing

**Gebruik getwiste toevoerdraden die geschikt zijn voor een temperatuur van minstens 30°C, d.w.z een hogere temperatuur dan die van de omgevingstemperatuur buiten de kast.**

## Varoitus

**Käytä kierrettyjä syöttöparihoitoja, jotka soveltuvat kotelon ulkopuolista lämpötilaa 30 °C:ta suuremmalle lämpötilalle.**

## Attention

**Utilisez des câbles à paires torsadées adaptés à des températures ambiantes supérieures à 30°C hors de l'armoire.**

## Warnung

**Verwenden Sie Twisted-Pair-Kabel, die für einen Einsatz bei 30° C über Umgebungstemperatur (außerhalb des Gehäuses) geeignet sind.**

## Avvertenza

**Usare cavi di alimentazione a doppino intrecciato adatti a una temperatura di 30°C superiore alla temperatura ambiente, al di fuori della struttura.**

## Advarsel

**Bruk snodde ledningspar som egner seg til 30 °C høyere temperatur enn omgivelsestemperaturen utenfor det avgrensede området.**

## Aviso

**Use cabos de alimentação de par trançado próprios para 86°F (30°C) acima da temperatura ambiente fora do gabinete.**

## ¡Advertencia!

**Utilice cables de suministro de par trenzados adecuados para temperaturas superiores en 30°C (86°F) a la temperatura ambiente exterior del alojamiento.**

## Varning!

**Använd partvinnade trådar som lämpar sig för 86 °F (30 °C) över omgivningstemperaturen utanför höljet.**

## Figyelem

**A házon kívül használjon olyan csavart érpáras kábelt, amely 30°C feletti környezeti hőmérsékletet is elvisel.**

- Предупреждение** Для монтажа электроцепей снаружи корпуса используйте витой двухжильный провод, предназначенный для эксплуатации при температуре, превышающей имеющуюся температуру окружающей среды на 86°F (30°C).
- 警告** 使用双绞式电源线，这样，当封闭罩外的温度超过 86°F (30°C) 时仍然适用。
- 警告** 格納ラック外では86°F (30°C) 以上の周囲温度に適したツイストペア電源配線を使用します。
- 

## Pollution Degree 2 Industrial Environment



### Warning

**This equipment is intended for use in a Pollution Degree 2 industrial environment, in overvoltage Category II applications (as defined in IEC publication 60664-1), and at altitudes up to 2000 meters without derating.**  
Statement 1068

### Waarschuwing

**Deze apparatuur is bestemd voor gebruik in een industriële omgeving met een vervuilingsgraad 2, bij toepassingen van overvoltage categorie II (zoals gedefinieerd in IEC-publicatie 60664-1) en bij hoogten van maximaal 2000 meter zonder de prestatie te verminderen.**

### Varoitus

**Tämä laite on tarkoitettu käytettäväksi saasteasteen 2 (Pollution Degree 2) mukaisissa teollisuusympäristöissä, ylijänniteluokan II mukaisissa käyttösovelluksissa (IEC-julkaisun 60664-1 määritelmän mukaisesti) ja korkeuden merenpinnasta ollessa enintään 2000 m ilman tehon heikkenemistä.**

### Attention

**Cet équipement doit être utilisé dans un environnement industriel de degré 2 de pollution, dans des applications de catégorie II de surtension (comme défini par le document 60664-1 de l'IEC) et à une altitude maximale de 2.000 mètres sans déclassement.**

<b>Warnung</b>	<b>Das Gerät ist für den Einsatz in einem Industriegebiet mit Verschmutzungsgrad 2, in Überspannungskategorie II (gemäß IEC-Veröffentlichung 60664-1) sowie bei einer Höhe von bis zu 2000 m ohne Unterlastung bestimmt.</b>
<b>Avvertenza</b>	<b>Quest'apparecchiatura è destinata all'uso in ambiente industriale con Grado di Inquinamento 2, in applicazioni di sovratensione di Categoria II (secondo quanto definito dalla pubblicazione IEC 60664-1) e a sino a 2000 metri di altitudine, senza abbassamenti di tensione.</b>
<b>Advarsel</b>	<b>Dette utstyret er beregnet for bruk i et industrielt miljø, forurensningsgrad 2, overspenningskategori II (som definert i IEC-kunngjøring 60664-1), og i høyder på opp til 2000 meter uten belastningsreduksjon.</b>
<b>Aviso</b>	<b>Este equipamento destina-se a uso em um ambiente industrial com Grau de Poluição 2, em aplicações de supervoltagem de Categoria II (conforme definido na publicação IEC 60664-1) e em altitudes de até 2000 metros sem descarga.</b>
<b>¡Advertencia!</b>	<b>Este equipo está diseñado para usarlo en un entorno industrial con grado de polución 2, con aplicaciones de sobretensión de Categoría II (según la definición de la publicación IEC 60664-1) y en altitudes de hasta 2.000 metros sin menoscabo de sus prestaciones.</b>
<b>Varning!</b>	<b>Denna utrustning är avsedd för användning i en industriell miljö, med nedsmutsningsgrad 2, i överspänningskategori II-tillämpningar (enligt definitionen i IEC publikation 60664-1), samt på upp till 2000 m höjd över havsnivån utan korrigerig.</b>
<b>Figyelem</b>	<b>A készülék 2-es szennyezettségi fokú ipari környezethez, II. kategóriájú túlfeszültségű alkalmazásokhoz készült (az IEC 60664-1 dokumentumban leírtak szerint); a névleges értékeket 2000 méter magasságig megtartja.</b>
<b>Предупреждение</b>	<b>Данное оборудование рассчитано на эксплуатацию в условиях окружающей среды, соответствующих индустриальному стандарту Pollution Degree 2, при перенапряжении по категории II (в соответствии со статьей IEC 60664-1) и на высоте до 2000 метров без снижения номинальных показателей.</b>

**警告** 此设备可在以下环境中使用且不会降低性能：2 级污染的工业环境，II 类超电压应用环境（如 IEC 刊物 60664-1 中定义）和海拔高达 2000 米的地方。

**警告** この装置は、汚染度2の産業環境、(IEC Publication 60664-1で規定されている) 過電圧Category IIアプリケーション、および海拔2000m以下で使用するよう に設計された製品です。

## Port Connection



### Warning

**Do not connect or disconnect cables to the ports while power is applied to the switch or any device on the network because an electrical arc can occur. This could cause an explosion in hazardous location installations. Be sure that power is removed from the switch and cannot be accidentally be turned on, or verify that the area is nonhazardous before proceeding.** Statement 1070

### Waarschuwing

**Als u de kabels aansluit op of ontkoppelt van de poorten terwijl er stroom op de schakelaar of op een ander apparaat op het netwerk staat, kan er een lichtboog optreden. Dit kan leiden tot een explosie bij installaties in gevaarlijke gebieden. Zorg dat er geen stroom op de schakelaar staat en dat deze niet per ongeluk kan worden aangezet, of controleer of het gebied niet gevaarlijk is voordat u doorgaat.**

### Varoitus

**Portteihin tulevia kaapeleita ei saa kytkeä tai irrottaa virran ollessa kytkettynä kytkimeen tai muuhun verkossa olevaan laitteeseen, koska voi muodostua valokaari. Tämä voi aiheuttaa räjähdysten vaarallisten paikkojen asennuksissa. Varmista ennen jatkamista, ettei kytkimeen tule virtaa ja ettei virtaa voida kytkeä vahingossa päälle tai ettei alue ole vaarallinen.**

- Attention** Lors de la connexion ou de la déconnexion de câbles, un arc électrique risque de se produire lorsque l'alimentation est reliée au commutateur ou à tout périphérique sur le réseau. Si le site est dangereux, ce phénomène risque de provoquer une explosion dans les sites dangereux. Assurez-vous de déconnecter l'alimentation des circuits de commutation et d'alarme et vérifiez que l'endroit ne présente aucun danger avant de poursuivre.
- Warnung** Schließen Sie keine Kabel an die Ports an bzw. entfernen Sie keine Kabel, wenn der Switch oder ein beliebiges anderes Gerät im Netzwerk an die Stromversorgungsquelle angeschlossen ist, da dies zu einem elektrischen Bogen führen kann. Dies kann bei Installationen in Gefahrenzonen eine Explosion zur Folge haben. Vergewissern Sie sich, dass am Switch kein Strom anliegt, und dass die Stromversorgung nicht versehentlich eingeschaltet werden kann, oder stellen Sie sicher, dass es sich beim gewählten Standort nicht um ein explosionsgefährdetes Gebiet handelt, bevor Sie fortfahren.
- Avvertenza** Non collegare o disconnettere i cavi dalle porte mentre è inserita l'alimentazione allo switch o qualsiasi dispositivo in rete per evitare la formazione di un arco elettrico. Ciò può causare un'esplosione in caso di installazioni in aree pericolose. Prima di procedere, accertarsi che l'alimentazione sia disinserita dallo switch e non possa essere accidentalmente inserita oppure verificare che l'area non sia pericolosa.
- Advarsel** Kabler må ikke tilkobles eller frakobles åpninger mens det er strøm til bryteren eller noen enhet på nettverket, fordi en elektrisk bue kan oppstå. Dette kunne forårsake en eksplosjon i installasjoner i farlige områder. Påse at strømmen er fjernet fra bryteren og ikke kan slås på uforvarende, eller kontroller at området ikke er farlig før du fortsetter.
- Aviso** Não conecte ou desconecte cabos de portas com a alimentação sendo fornecida ao switch ou a qualquer dispositivo da rede, porque poderá ocorrer um arco elétrico. Isso pode causar uma explosão em instalações em áreas de risco. Certifique-se de que a alimentação do switch foi interrompida e de que não há possibilidade de ser acionada acidentalmente ou verifique se a área é segura antes de prosseguir.

- ¡Advertencia!** **No conecte ni desconecte los cables de los puertos mientras se suministra alimentación al switch o a cualquier dispositivo de la red. De lo contrario se puede crear un arco eléctrico que podría provocar una explosión en una zona de instalaciones peligrosas. Antes de continuar, asegúrese de que se ha interrumpido el suministro de alimentación al switch y de que no se puede recuperar el suministro de forma accidental o compruebe que el área no sea peligrosa.**
- Varning!** **Du får inte ansluta kablar till portar eller koppla loss dem medan strömmen är kopplad till omkopplaren eller någon anordning inom nätverket, eftersom detta kan ge upphov till en elbåge. Detta kan orsaka en explosion på farliga installationsplatser. Se till att omkopplaren inte är spänningssatt samt att den inte kan slås på oavsiktligt, och verifiera att området inte är farligt innan du fortsätter.**
- Figyelem** **Ha csatlakoztat vagy kihúz bármilyen csatlakozókábelt, elektromos ív jöhet létre, ha a kapcsoló vagy a hálózatban lévő bármely eszköz feszültség alatt van. Ha a készülék veszélyes helyre van telepítve, ez robbanást okozhat. Győződjön meg róla, hogy a kapcsoló nincs feszültség alatt, véletlenül nem kapcsolható be, és mielőtt továbblép, ellenőrizze, hogy a terület nem veszélyes-e.**
- Предупреждение** **Не подключайте и не отключайте кабели к разъемам при поданном на переключатель или какое-либо другое устройство цепи напряжением питания, так как это может привести к возникновению электрической дуги. Это может привести к взрыву во взрывоопасной среде. Перед выполнением каких-либо действий убедитесь в том, что напряжение питания отключено и не может быть случайно включено, или в том, что окружающая среда не является взрывоопасной.**

**警告** 当交换机或网上的任一设备的电源接通时不要在端口插拔电缆，因为这可能产生电弧。如果是在危险的地方安装，就会引发爆炸。应确保交换机已断电且不会意外接通电源，或确定该地区不存在危险，然后再安装。

**警告** スイッチまたはネットワーク上の装置が通電状態のときは、ケーブルをポートへ接続したり、ポートから引き抜いたりしないでください。電気アークが発生することがあります。電気アークは、危険な場所での設置の際に爆発を引き起こすことがあります。電源がスイッチから切断されていて偶発的に電源が入らないこと、または作業場所が危険でないことを確認してから作業を進めてください。

## Installation Instructions



### Warning

**Read the installation instructions before connecting the system to the power source.** Statement 1004

### Waarschuwing

**Raadpleeg de installatie-instructies voordat u het systeem op de voedingsbron aansluit.**

### Varoitus

**Lue asennusohjeet ennen järjestelmän yhdistämistä virtälähteeseen.**

### Attention

**Avant de brancher le système sur la source d'alimentation, consulter les directives d'installation.**

### Warnung

**Vor dem Anschließen des Systems an die Stromquelle die Installationsanweisungen lesen.**

### Avvertenza

**Consultare le istruzioni di installazione prima di collegare il sistema all'alimentatore.**

### Advarsel

**Les installasjonsinstruksjonene før systemet kobles til strømkilden.**



<b>Aviso</b>	<b>Leia as instruções de instalação antes de ligar o sistema à fonte de energia.</b>
<b>¡Advertencia!</b>	<b>Lea las instrucciones de instalación antes de conectar el sistema a la red de alimentación.</b>
<b>Varning!</b>	<b>Läs installationsanvisningarna innan du kopplar systemet till strömförsörjningsenheten.</b>
<b>Figyelem</b>	<b>Mielőtt áramforráshoz csatlakoztatná a rendszert, olvassa el az üzembe helyezési útmutatót!</b>
<b>Предупреждение</b>	<b>Перед подключением устройства к источнику электропитания ознакомьтесь с данной инструкцией по установке.</b>
<b>警告</b>	<b>在将系统与电源连接之前，请仔细阅读安装说明。</b>
<b>警告</b>	<b>必ず設置手順を読んでから、システムを電源に接続してください。</b>

## Service Personnel Warning



### Warning

**This equipment is to be installed and maintained by service personnel only as defined by AS/NZS 3260 Clause 1.2.14.3 Service Personnel.** Statement 88

### Waarschuwing

**Deze apparatuur mag slechts geïnstalleerd en onderhouden worden door servicepersoneel conform de definitie van AS/NZS 3260 Clausule 1.2.14.3 Service Personnel.**

### Varoitus

**Tämän laitteen saa asentaa tai huoltaa ainoastaan Australiassa ja Uudessa Seelannissa sovellettavan AS/NZS 3260 -standardin kohdan 1.2.14.3 Service Personnel määrittelemä huoltohenkilöstö.**

■ Service Personnel Warning

<b>Attention</b>	<b>Cet équipement ne doit être installé et entretenu que par du personnel d'entretien comme défini par la réglementation AS/NZS 3260 Clause 1.2.14.3 Service Personnel.</b>
<b>Warnung</b>	<b>Dieses Gerät darf nur von Wartungspersonal gemäß AS/NZS-Definition 3260, Paragraph 1.2.14.3, "Service Personnel", installiert und gewartet werden.</b>
<b>Avvertenza</b>	<b>Questo apparecchio deve essere installato e mantenuto in efficienza esclusivamente da personale tecnico che soddisfi i requisiti specificati nella sezione 1.2.14.3 sul 'Service Personnel' contenuta nelle norme AS/NZS 3260.</b>
<b>Advarsel</b>	<b>Installasjon og vedlikehold av dette utstyret skal kun foretas av vedlikeholdspersonell som definert i AS/NZS 3260, klausul 1.2.14.3 Service Personnel.</b>
<b>Aviso</b>	<b>Este equipamento deverá ser instalado e reparado apenas por pessoal de manutenção qualificado, conforme estipulado em AS/NZS 3260 Cláusula 1.2.14.3 Service Personnel.</b>
<b>¡Advertencia!</b>	<b>Este equipo se debe instalar y mantener solamente por personal de servicio, según definido por AS/NZS 3260 Cláusula 1.2.14.3 Service Personnel.</b>
<b>Varning!</b>	<b>Installation och underhåll av denna utrustning får endast utföras av servicepersonal enligt definition i AS/NZS 3260 klausul 1.2.14.3 Service Personnel.</b>
<b>Figyelem</b>	<b>A készüléket az AS/NZS 3260 előírás „1.2.14.3 Service Personnel” pontja értelmében csak hozzáértő szakemberek helyezhetik üzembe és tarthatják karban.</b>
<b>Предупреждение</b>	<b>Данное оборудование должно устанавливаться и обслуживаться квалифицированным персоналом в соответствии с пунктом 1.2.14.3 «Обслуживающий персонал» стандарта AS/NZS 3260.</b>

**警告** 此设备应该仅由按 AS/NZS 3260 条款 1.2.14.3 “维修人员” 一节所规定的维修人员进行安装和维护。

**警告** この装置の設置およびメンテナンス作業は、AS/NZS 3260 の 1.2.14.3 条に定義されているサービス要員が行う必要があります。

## Stacking the Chassis Warning



### Warning

**Do not stack the chassis on any other equipment. If the chassis falls, it can cause severe bodily injury and equipment damage.** Statement 48

### Waarschuwing

**Het chassis mag niet op andere apparatuur gestapeld te worden. Als het chassis mocht vallen, kan dit ernstig lichamelijk letsel en beschadiging van de apparatuur veroorzaken.**

### Varoitus

**Älä aseta asennuspohjaa minkään muun laitteen päälle. Asennuspohja voi pudotessaan aiheuttaa vaikean ruumiinvamman tai laiteaurion.**

### Avertissement

**Ne placez pas ce châssis sur un autre appareil. En cas de chute, il pourrait provoquer de graves blessures corporelles et d'importants dommages.**

### Achtung

**Das Gehäuse nicht auf andere Geräte stellen. Wenn das Gehäuse herunterfällt, besteht Gefahr schwerer Personenverletzungen und Geräteschäden.**

### Avvertenza

**Non collocare lo chassis su nessun altro apparecchio. Se lo chassis cade, può causare lesioni gravi e danni alle apparecchiature.**

### Advarsel

**Stable ikke kabinettet oppå annet utstyr. Hvis kabinettet faller, kan det forårsake alvorlig skade på mennesker og utstyr.**

## Ground Connection Warning

<b>Aviso</b>	<b>Não coloque o chassis em cima de qualquer outro equipamento. Se o chassis cair, poderá causar ferimentos graves e danos no equipamento.</b>
<b>¡Atención!</b>	<b>No apilar los chasis sobre ningún otro equipo. Si el chasis se cae al suelo puede causar graves lesiones físicas y daños al equipo.</b>
<b>Varning</b>	<b>Placera inte chassit ovanpå annan utrustning. Om chassit faller kan allvarlig kroppsskada såväl som skada på utrustningen uppstå.</b>
<b>Figyelem</b>	<b>A készüléket ne tegye rá másik készülékre. Ha a készülék leesik, súlyos testi sérülést okozhat, és maga a készülék is megkárosodhat.</b>
<b>Предупреждение</b>	Не устанавливайте данное устройство на любое другое оборудование. Если устройство упадет, то это может привести к тяжелым травмам и повреждению оборудования.
<b>警告</b>	不要将底盘堆放在其它任何设备上。如果底盘倒下，可能使身体受伤并损坏设备。
<b>警告</b>	別のいかなる装置の上にもシャーシを載せないでください。シャーシを落とすと、大けがをしたり装置を損傷させたりする場合があります。

# Ground Connection Warning



**Warning**

**When installing the unit, always make the ground connection first and disconnect it last.** Statement 42

**Waarschuwing**

**Bij de installatie van het toestel moet de aardverbinding altijd het eerste worden gemaakt en het laatste worden losgemaakt.**

<b>Varoitus</b>	<b>Laitetta asennettaessa on maahan yhdistäminen aina tehtävä ensiksi ja maadoituksen irti kytkeminen viimeiseksi.</b>
<b>Attention</b>	<b>Lors de l'installation de l'appareil, la mise à la terre doit toujours être connectée en premier et déconnectée en dernier.</b>
<b>Warnung</b>	<b>Der Erdanschluß muß bei der Installation der Einheit immer zuerst hergestellt und zuletzt abgetrennt werden.</b>
<b>Avvertenza</b>	<b>In fase di installazione dell'unità, eseguire sempre per primo il collegamento a massa e disconnetterlo per ultimo.</b>
<b>Advarsel</b>	<b>Når enheten installeres, må jordledningen alltid tilkobles først og frakobles sist.</b>
<b>Aviso</b>	<b>Ao instalar a unidade, a ligação à terra deverá ser sempre a primeira a ser ligada, e a última a ser desligada.</b>
<b>¡Advertencia!</b>	<b>Al instalar el equipo, conectar la tierra la primera y desconectarla la última.</b>
<b>Varning!</b>	<b>Vid installation av enheten måste jordledningen alltid anslutas först och kopplas bort sist.</b>
<b>Figyelem</b>	<b>A készülék üzembe helyezése közben mindig a földelővezetéket kell elsőként csatlakoztatni és azt kell utolsóként leválasztani.</b>
<b>Предупреждение</b>	<b>При установке устройства контакт заземления должен подключаться первым, а отключаться последним.</b>
<b>警告</b>	<b>安装部件时，必须首先进行接地连接，而断开接地连接应在最后进行。</b>
<b>警告</b>	<b>ユニットを設置する場合、アース端子は常に最初に接続し、最後に切断してください。</b>

# SELV-IEC 60950 DC Power Supply



## Warning

**Connect the unit only to DC power source that complies with the safety extra-low voltage (SELV) requirements in IEC 60950 based safety standards.**  
Statement 1033

## Waarschuwing

**Sluit de eenheid alleen maar aan op een gelijkstroombron die voldoet aan de veiligheidsvereisten voor extra-laag voltage (SELV) in de op IEC 60950 gebaseerde veiligheidsnormen.**

## Varoitus

**Liitä laite ainoastaan tasavirtalähteeseen, joka on yhdenmukainen IEC 60950:n suojattujen erittäisen alhaisen jännitteen (SELV) turvavaatimusten kanssa.**

## Attention

**Connectez l'unité uniquement à une alimentation CC compatible avec les recommandations SELV (safety extra-low voltage) des normes de sécurité IEC 60950.**

## Warnung

**Schließen Sie die Einheit nur an eine Gleichstrom-Stromquelle an, die mit den Safety Extra-Low Voltage (SELV)-Anforderungen in den auf IEC 60950 basierenden Sicherheitsstandards übereinstimmen.**

## Avvertenza

**Collegare l'unità esclusivamente a una presa di corrente continua rispondente ai requisiti SELV (safety extra-low voltage) in base alle norme di sicurezza IEC 60950.**

## Advarsel

**Koble bare enheten til en likestrømsforsyning som er i henhold til kravene for lavspenning (SELV) i IEC 60950-baserte sikkerhetsstandarder.**

## Aviso

**Conecte a unidade apenas à fonte da energia de CC que se encontra em conformidade com os requisitos dos circuitos de segurança de baixa tensão (SELV) constantes dos padrões de segurança baseados no IEC 60950.**

## ¡Advertencia!

**Conecte la unidad sólo en una fuente de energía DC que cumpla con los requisitos de voltaje extra bajo (SELV - safety extra-low voltage) en los estándares de seguridad IEC 60950.**

**Varning!** Anslut enheten endast till en likströmsförsörjningsenhet som uppfyller kraven för SELV (skyddskretsar för mycket låg spänning) i IEC 60950-baserade säkerhetsstandarder.

**Figyelem** Csak olyan, váltakozó feszültségű áramforráshoz csatlakoztassa a készüléket, amely megfelel az IEC 60950-es számú biztonsági szabványon alapuló biztonságos törpefeszültségi (SELV) követelményeknek.

**Предупреждение** Это устройство можно подключать только к источнику постоянного тока, соответствующему требованиям к цепям безопасного низковольтного напряжения (SELV) стандарта безопасности IEC 60950.

**警告** 请只将该部件连接到符合基于 IEC 60950 的安全标准中安全特低电压 (SELV) 要求的直流电源上。

**警告** この装置は、安全規格に基づく IEC 60950 の Safety Extra-Low Voltage (SELV) 要件を満たす DC 電源にのみ接続してください。

## Jewelry Removal Warning



**Warning**

**Before working on equipment that is connected to power lines, remove jewelry (including rings, necklaces, and watches). Metal objects will heat up when connected to power and ground and can cause serious burns or weld the metal object to the terminals.** Statement 43

**Waarschuwing**

**Alvorens aan apparatuur te werken die met elektrische leidingen is verbonden, sieraden (inclusief ringen, kettingen en horloges) verwijderen. Metalen voorwerpen worden warm wanneer ze met stroom en aarde zijn verbonden, en kunnen ernstige brandwonden veroorzaken of het metalen voorwerp aan de aansluitklemmen lassen.**

**Jewelry Removal Warning**

<b>Varoitus</b>	<b>Ennen kuin työskentelet voimavirtajohtoihin kytkettyjen laitteiden parissa, ota pois kaikki korut (sormukset, kaulakorut ja kellot mukaan lukien). Metalliesineet kuumenevat, kun ne ovat yhteydessä sähkövirran ja maan kanssa, ja ne voivat aiheuttaa vakavia palovammoja tai hitsata metalliesineet kiinni liitännänpoihin.</b>
<b>Attention</b>	<b>Avant d'accéder à cet équipement connecté aux lignes électriques, ôter tout bijou (anneaux, colliers et montres compris). Lorsqu'ils sont branchés à l'alimentation et reliés à la terre, les objets métalliques chauffent, ce qui peut provoquer des blessures graves ou souder l'objet métallique aux bornes.</b>
<b>Warnung</b>	<b>Vor der Arbeit an Geräten, die an das Netz angeschlossen sind, jeglichen Schmuck (einschließlich Ringe, Ketten und Uhren) abnehmen. Metallgegenstände erhitzen sich, wenn sie an das Netz und die Erde angeschlossen werden, und können schwere Verbrennungen verursachen oder an die Anschlußklemmen angeschweißt werden.</b>
<b>Avvertenza</b>	<b>Prima di intervenire su apparecchiature collegate alle linee di alimentazione, togliersi qualsiasi monile (inclusi anelli, collane, braccialetti ed orologi). Gli oggetti metallici si riscaldano quando sono collegati tra punti di alimentazione e massa: possono causare ustioni gravi oppure il metallo può saldarsi ai terminali.</b>
<b>Advarsel</b>	<b>Fjern alle smykker (inkludert ringer, halskjeder og klokker) før du skal arbeide på utstyr som er koblet til kraftledninger. Metallgjenstander som er koblet til kraftledninger og jord blir svært varme og kan forårsake alvorlige brannskader eller smelte fast til polene.</b>
<b>Aviso</b>	<b>Antes de trabalhar em equipamento que esteja ligado a linhas de corrente, retire todas as jóias que estiver a usar (incluindo anéis, fios e relógios). Os objectos metálicos aquecerão em contacto com a corrente e em contacto com a ligação à terra, podendo causar queimaduras graves ou ficarem soldados aos terminais.</b>
<b>¡Advertencia!</b>	<b>Antes de operar sobre equipos conectados a líneas de alimentación, quitarse las joyas (incluidos anillos, collares y relojes). Los objetos de metal se calientan cuando se conectan a la alimentación y a tierra, lo que puede ocasionar quemaduras graves o que los objetos metálicos queden soldados a los bornes.</b>



- Varning!** Tag av alla smycken (inklusive ringar, halsband och armbandsur) innan du arbetar på utrustning som är kopplad till kraftledningar. Metallobjekt hettas upp när de kopplas ihop med ström och jord och kan förorsaka allvarliga brännskador; metallobjekt kan också sammansvetsas med kontakterna.
- Figyelem** Mielőtt hálózati feszültséghez csatlakozó készülékkel kezd el dolgozni, vegye le magáról az ékszereket (például gyűrűt, nyakláncot, órát). A fém tárgyak felmelegszenek, ha hálózati feszültséghez és földhöz érnek, és súlyos égési sérülést okozhatnak, illetve a fém tárgyak hozzáforrhathatnak a csatlakozókhoz.
- Предупреждение** Прежде чем использовать оборудование, подключенное к электросети, снимите все украшения (включая кольца, ожерелья и часы). Металлические части нагреваются при соединении с источником питания и землей, что может привести к серьезным ожогам или привариванию металлических объектов к клеммам.
- 警告** 在操作与电源线连接的设备以前，请取下首饰（包括戒指、项链和手表）。连接电源和接地后，金属物品会升温，可能导致严重灼伤，也可能使金属物品熔接在线端。
- 警告** 電源に接続されている装置を取り扱う際は、事前に、指輪、ネックレス、腕時計などの装身具をはずしてください。金属のオブジェクトが電源とアースと接触すると、金属が過熱して大やけどをしたり、また金属類が端子に焼き付くことがあります。

## Product Disposal Warning



**Warning**

**Ultimate disposal of this product should be handled according to all national laws and regulations.** Statement 180

**Waarschuwing**

**Het uiteindelijke wegruimen van dit product dient te geschieden in overeenstemming met alle nationale wetten en reglementen.**

■ Product Disposal Warning

**Varoitus** Tämä tuote on hävitettävä kansallisten lakien ja määräysten mukaisesti.

**Attention** La mise au rebut ou le recyclage de ce produit sont généralement soumis à des lois et/ou directives de respect de l'environnement. Renseignez-vous auprès de l'organisme compétent.

**Warnung** Die Entsorgung dieses Produkts sollte gemäß allen Bestimmungen und Gesetzen des Landes erfolgen.

**Avvertenza** Lo smaltimento di questo prodotto deve essere eseguito secondo le leggi e regolazioni locali.

**Advarsel** Endelig kassering av dette produktet skal være i henhold til alle relevante nasjonale lover og bestemmelser.

**Aviso** Deitar fora este produto em conformidade com todas as leis e regulamentos nacionais.

**¡Advertencia!** Al deshacerse por completo de este producto debe seguir todas las leyes y reglamentos nacionales.

**Varning!** Vid deponering hanteras produkten enligt gällande lagar och bestämmelser.

**Figyelem** A készülék végső elhelyezéséről az adott országban érvényes törvények és előírások szerint kell intézkedni.

**Предупреждение** Окончательная установка данного изделия должна выполняться в соответствии со всеми региональными и местными правилами и нормами.

**警告** 本产品的废弃处理应根据所有国家的法律和规章进行。

**警告** この製品を廃棄するときは、各国の法律および規制に従って処理してください。

# Class 1 Laser Product



**Warning** **Class 1 laser product.** Statement 1008

**Waarschuwing** **Klasse-1 laser produkt.**

**Varoitus** **Luokan 1 lasertuote.**

**Attention** **Produit laser de classe 1.**

**Warnung** **Laserprodukt der Klasse 1.**

**Avvertenza** **Prodotto laser di Classe 1.**

**Advarsel** **Laserprodukt av klasse 1.**

**Aviso** **Produto laser de classe 1.**

**¡Advertencia!** **Producto láser Clase I.**

**Varning!** **Laserprodukt av klass 1.**

**Figyelem** **Class 1 besorolású lézeres termék.**

**Предупреждение** **Лазерное устройство класса 1.**

**警告** **这是 1 类激光产品。**

**警告** **クラス1レーザー製品です。**

**주의** **1급 레이저 제품.**

■ Class 1 LED Product

تذير Class 1 Laser منتج

Upozorenje Laserski proizvod klase 1

Upozornění Laserový výrobek třídy 1.

Προειδοποίηση Προϊόν λέιζερ κατηγορίας 1.

Figyelem Class 1 besorolású lézeres termék.

Предупреждение Лазерное устройство класса 1.

警告 这是 1 类激光产品。

警告 クラス1レーザー製品です。

주의 1급 레이저 제품.

تذير Class 1 Laser منتج

Upozorenje Laserski proizvod klase 1

## Class 1 LED Product



**Warning**

**Class 1 LED product.** Statement 1027

**Waarschuwing**

**Klasse 1 LED-product**

<b>Varoitus</b>	<b>Luokan 1 valodiodituote</b>
<b>Attention</b>	<b>Alarme de produit LED Class I</b>
<b>Warnung</b>	<b>Class 1 LED-Produktwarnung</b>
<b>Avvertenza</b>	<b>Avvertenza prodotto LED di Classe 1</b>
<b>Advarsel</b>	<b>LED-produkt i klasse 1</b>
<b>Aviso</b>	<b>Produto de classe 1 com LED</b>
<b>¡Advertencia!</b>	<b>Aviso sobre producto LED de Clase 1</b>
<b>Varning!</b>	<b>Lysdiodprodukt av klass 1</b>
<b>Figyelem</b>	<b>Class 1 besorolású LED termék.</b>
<b>Предупреждение</b>	<b>Светодиодное устройство класса 1.</b>
<b>警告</b>	<b>这是 1 类 LED 产品</b>
<b>警告</b>	<b>クラス1 LED製品です。</b>

---

# Laser Radiation



## Warning

**Invisible laser radiation may be emitted from disconnected fibers or connectors. Do not stare into beams or view directly with optical instruments.**

Statement 1051

## Waarschuwing

**Losgekoppelde of losgeraakte glasvezels of aansluitingen kunnen onzichtbare laserstraling produceren. Kijk niet rechtstreeks in de straling en gebruik geen optische instrumenten rond deze glasvezels of aansluitingen.**

## Varoitus

**Irrotetuista kuiduista tai liittimistä voi tulla näkymätöntä lasersäteilyä. Älä tuijota säteitä tai katso niitä suoraan optisilla välineillä.**

## Attention

**Les fibres ou connecteurs débranchés risquent d'émettre des rayonnements laser invisibles à l'œil. Ne regardez jamais directement les faisceaux laser à l'œil nu, ni d'ailleurs avec des instruments optiques.**

## Warnung

**Unterbrochene Fasern oder Steckerverbindungen können unsichtbare Laserstrahlung abgeben. Blicken Sie weder mit bloßem Auge noch mit optischen Instrumenten direkt in Laserstrahlen.**

## Avvertenza

**Le fibre ottiche ed i relativi connettori possono emettere radiazioni laser. I fasci di luce non devono mai essere osservati direttamente o attraverso strumenti ottici.**

## Advarsel

**Det kan forekomme usynlig laserstråling fra fiber eller kontakter som er frakoblet. Stirr ikke direkte inn i strålene eller se på dem direkte gjennom et optisk instrument.**

## Aviso

**Radiação laser invisível pode ser emitida de conectores ou fibras desconectadas. Não olhe diretamente para os feixes ou com instrumentos ópticos.**

## ¡Advertencia!

**Es posible que las fibras desconectadas emitan radiación láser invisible. No fije la vista en los rayos ni examine éstos con instrumentos ópticos.**

<b>Varning!</b>	<b>Osynlig laserstrålning kan avges från frånkopplade fibrer eller kontaktdon. Rikta inte blicken in i strålar och titta aldrig direkt på dem med hjälp av optiska instrument.</b>
<b>Figyelem</b>	<b>A nem csatlakoztatott üvegszálak és csatlakozók láthatatlan lézersugárzást bocsáthatnak ki. Ne nézzen bele a sugárba, és ne nézze közvetlenül, optikai berendezések segítségével!</b>
<b>Предупреждение</b>	Отключенные световоды и разъемы могут испускать невидимое лазерное излучение. Не допускайте попадания лазерного луча в глаза и не смотрите на него через оптические приборы.
<b>警告</b>	断开的光纤或接头有可能发出不可见的激光辐射。请勿直视光束或直接用光学仪器观看光束。
<b>警告</b>	光ファイバ ケーブルまたはコネクタを取り外した状態では、目に見えないレーザー光が放射されていることがあります。光線をのぞきこんだり、光学機器を使用して光線を直接見たりしないでください。
<b>تحذير</b>	من المحتمل انبعاث أشعة الليزر من الألياف غير المتصلة أو التوصيلات. لا تحقق النظر في الشعاع أو النظر مباشرة بدون أي أداة بصرية.
<b>Upozorenje</b>	<b>Postoji mogućnost laserskog zračenja iz iskopčanih vlakana ili priključaka. Nemojte gledati izravno u zrake niti ih promatrati optičkim instrumentima.</b>
<b>Upozornění</b>	<b>Odpojená vlákna kabelů či konektory mohou vyzařovat neviditelné laserové záření. Nedívejte se do paprsků ani nepozorujte přímo pomocí optických přístrojů.</b>
<b>Προειδοποίηση</b>	Από αποσυνδεδεμένες ίνες ή υποδοχές μπορεί να εκπέμπεται αόρατη ακτινοβολία λέιζερ. Μην κοιτάτε απευθείας τις δέσμες φωτός και μην τις απεικονίζετε απευθείας με οπτικά όργανα.

## Laser Viewing Warning

- Upozorenje** Postoji mogućnost laserskog zračenja iz iskopčanih vlakana ili priključaka. Nemojte gledati izravno u zrake niti ih promatrati optičkim instrumentima.
- Upozornění** Odpojená vlákna kabelů či konektory mohou vyzářovat neviditelné laserové záření. Nedívejte se do paprsků ani nepozorujte přímo pomocí optických přístrojů.

# Laser Viewing Warning



## Warning

For diverging beams, viewing the laser output with certain optical instruments within a distance of 100 mm may harm your eyes. For collimated beams, viewing the laser output with certain optical instruments designed for use at a distance may harm your eyes. Statement 282

## Waarschuwing

Voor divergerende stralen kan het bekijken van de laseruitvoer met bepaalde optische instrumenten binnen een afstand van 100 mm gevaar voor de ogen opleveren. Voor collimerende stralen kan het bekijken van de laseruitvoer met bepaalde optische instrumenten die bestemd zijn voor gebruik op afstand gevaar voor de ogen opleveren.

## Varoitus

Divergoivien lasersäteiden katselu tietyillä optisilla laitteilla 100 millimetrin etäisyydeltä saattaa vahingoittaa silmiä. Kollimoivien lasersäteiden katselu tietyillä etäkäyttöisillä optisilla laitteilla saattaa vahingoittaa silmiä.

## Attention

Pour les faisceaux divergents, observer la sortie laser avec certains instruments optiques à une distance de moins de 100 mm peut être nocif pour les yeux. Pour les faisceaux collimatés, observer la sortie laser avec certains instruments optiques conçus pour être utilisés à distance peut être nocif pour les yeux.



<b>Warnung</b>	<b>Bei auseinandergehenden Strahlen kann das Betrachten des Laserausgangs mit optischen Instrumenten innerhalb einer Distanz von 100 mm die Augen gefährden. Bei gerichteten Strahlen stellt das Betrachten des Laserausgangs mit bestimmten optischen Instrumenten, die für den Gebrauch in einer bestimmten Entfernung vorgesehen sind, eine Gefährdung der Augen dar.</b>
<b>Figyelem!</b>	<b>Divergens sugarak esetén: ha 100 mm-nél kisebb távolságból bizonyos optikai eszközökkel nézi a kibocsátott lézert, látáskárosodást szenvedhet. Párhuzamos sugarak esetén: ha bizonyos, távoli használatra készült optikai eszközökkel nézi a kibocsátott lézert, látáskárosodást szenvedhet.</b>
<b>Avvertenza</b>	<b>Per fasci divergenti, l'osservazione dell'emissione laser con certi strumenti ottici entro una distanza di 100 mm può danneggiare gli occhi. Per fasci collimati, l'osservazione dell'emissione laser con certi strumenti ottici realizzati per l'utilizzo a distanza può danneggiare gli occhi.</b>
<b>Advarsel</b>	<b>Når det er spredningsstråler til stede kan det medføre fare for øynene å observere lasereffekten med visse optiske instrumenter innenfor en avstand på 100 mm. Når det er parallellstråler til stede, kan det medføre fare for øynene å observere lasereffekten med visse optiske instrumenter som er fremstilt til bruk med en viss avstand.</b>
<b>Aviso</b>	<b>Em feixes divergentes, olhar a emissão de laser com determinados instrumentos ópticos a uma distância de até 100mm pode causar danos à visão. Em feixes colimados, olhar a emissão de laser com instrumentos ópticos apropriados para serem utilizados para visualização à distância pode causar danos à visão.</b>
<b>¡Advertencia!</b>	<b>En los haces divergentes, la visualización de la salida del láser con determinados instrumentos ópticos a una distancia de 100 mm puede dañar la vista. En los haces colimados, la visualización de la salida del láser con determinados instrumentos ópticos diseñados para el uso a distancia puede dañar la vista.</b>
<b>Varning!</b>	<b>Vid divergerande utstrålning, kan dina ögon skadas om du betraktar lasern med vissa optiska instrument inom en distans på 100 mm. Vid parallell utstrålning kan dina ögon skadas om du betraktar laserstrålen med vissa optiska instrument.</b>

<b>Предупреждение</b>	Нельзя смотреть на источник рассеянного лазерного излучения через некоторые оптические приборы с расстояния менее 100 мм: это может привести к травме органов зрения. Опасно смотреть на направленное лазерное излучение через оптические приборы, предназначенные для работы на расстоянии: это может привести к травме органов зрения.
<b>警告</b>	对于发散光束，在 100 毫米的距离内用某些光学仪器观看激光输出有可能伤害眼睛。对于平行光束，使用设计为在一定距离进行观看的某些光学仪器来观看激光输出也可能会伤害眼睛。
<b>警告</b>	ある種の光学機器を使用して100 mm以内の距離からレーザー光線を見ると、拡散ビームによって目を痛めることがあります。離れた場所から使用することを前提とする、ある種の光学機器を使用してレーザー光線を見ると、平行ビームによって目を痛めることがあります。

## Laser Beam Exposure



### Warning

**Avoid direct exposure to the laser beam.** Statement 1012

### Waarschuwing

**Voorkom rechtstreekse blootstelling aan de laserstraal.**

### Varoitus

**Vältä säteelle altistumista.**

### Attention

**Éviter toute exposition directe au faisceau.**

### Warnung

**Schützen Sie sich vor direkter Laserbestrahlung.**

### Avvertenza

**Evitare l'esposizione diretta al raggio laser.**

### Advarsel

**Unngå direkte eksponering til laserstrålen.**

### Aviso

**Evite exposição a raios laser.**

**¡Advertencia!** Evite la exposición directa al haz del láser.

**Varning!** Utsätt dig inte för laserstrålning.

**Figyelem** Kerülje a lézersugárral való közvetlen érintkezést!

**Предупреждение** Избегайте прямого воздействия лазерного луча.

**警告** 注意避免遭受激光光束的直接辐射。

**警告** レーザー光線を直接浴びないように注意してください。

---

# Chassis Warning for Rack-Mounting and Servicing



## Warning

To prevent bodily injury when mounting or servicing this unit in a rack, you must take special precautions to ensure that the system remains stable. The following guidelines are provided to ensure your safety:

- This unit should be mounted at the bottom of the rack if it is the only unit in the rack.
- When mounting this unit in a partially filled rack, load the rack from the bottom to the top with the heaviest component at the bottom of the rack.
- If the rack is provided with stabilizing devices, install the stabilizers before mounting or servicing the unit in the rack. Statement 1006

## Waarschuwing

Om lichamelijk letsel te voorkomen wanneer u dit toestel in een rek monteert of het daar een servicebeurt geeft, moet u speciale voorzorgsmaatregelen nemen om ervoor te zorgen dat het toestel stabiel blijft. De onderstaande richtlijnen worden verstrekt om uw veiligheid te verzekeren:

- Dit toestel dient onderaan in het rek gemonteerd te worden als het toestel het enige in het rek is.
- Wanneer u dit toestel in een gedeeltelijk gevuld rek monteert, dient u het rek van onderen naar boven te laden met het zwaarste onderdeel onderaan in het rek.
- Als het rek voorzien is van stabiliseringshulpmiddelen, dient u de stabilisatoren te monteren voordat u het toestel in het rek monteert of het daar een servicebeurt geeft.

## Varoitus

Kun laite asetetaan telineeseen tai huolletaan sen ollessa telineessä, on noudatettava erityisiä varotoimia järjestelmän vakavuuden säilyttämiseksi, jotta vältetään loukkaantumiselta. Noudata seuraavia turvallisuusohjeita:

- Jos telineessä ei ole muita laitteita, aseta laite telineen alaosaan.
- Jos laite asetetaan osaksi täytettyyn telineeseen, aloita kuormittaminen sen alaosasta kaikkein raskaimmalla esineellä ja siirry sitten sen yläosaan.
- Jos telinettä varten on vakaimet, asenna ne ennen laitteen asettamista telineeseen tai sen huoltamista siinä.

- Attention** Pour éviter toute blessure corporelle pendant les opérations de montage ou de réparation de cette unité en casier, il convient de prendre des précautions spéciales afin de maintenir la stabilité du système. Les directives ci-dessous sont destinées à assurer la protection du personnel:
- Si cette unité constitue la seule unité montée en casier, elle doit être placée dans le bas.
  - Si cette unité est montée dans un casier partiellement rempli, charger le casier de bas en haut en plaçant l'élément le plus lourd dans le bas.
  - Si le casier est équipé de dispositifs stabilisateurs, installer les stabilisateurs avant de monter ou de réparer l'unité en casier.
- Warnung** Zur Vermeidung von Körperverletzung beim Anbringen oder Warten dieser Einheit in einem Gestell müssen Sie besondere Vorkehrungen treffen, um sicherzustellen, daß das System stabil bleibt. Die folgenden Richtlinien sollen zur Gewährleistung Ihrer Sicherheit dienen:
- Wenn diese Einheit die einzige im Gestell ist, sollte sie unten im Gestell angebracht werden.
  - Bei Anbringung dieser Einheit in einem zum Teil gefüllten Gestell ist das Gestell von unten nach oben zu laden, wobei das schwerste Bauteil unten im Gestell anzubringen ist.
  - Wird das Gestell mit Stabilisierungszubehör geliefert, sind zuerst die Stabilisatoren zu installieren, bevor Sie die Einheit im Gestell anbringen oder sie warten.
- Avvertenza** Per evitare infortuni fisici durante il montaggio o la manutenzione di questa unità in un supporto, occorre osservare speciali precauzioni per garantire che il sistema rimanga stabile. Le seguenti direttive vengono fornite per garantire la sicurezza personale:
- Questa unità deve venire montata sul fondo del supporto, se si tratta dell'unica unità da montare nel supporto.
  - Quando questa unità viene montata in un supporto parzialmente pieno, caricare il supporto dal basso all'alto, con il componente più pesante sistemato sul fondo del supporto.
  - Se il supporto è dotato di dispositivi stabilizzanti, installare tali dispositivi prima di montare o di procedere alla manutenzione dell'unità nel supporto.

**Advarsel** Unngå fysiske skader under montering eller reparasjonsarbeid på denne enheten når den befinner seg i et kabinett. Vær nøye med at systemet er stabilt. Følgende retningslinjer er gitt for å verne om sikkerheten:

- Denne enheten bør monteres nederst i kabinettet hvis dette er den eneste enheten i kabinettet.
- Ved montering av denne enheten i et kabinett som er delvis fylt, skal kabinettet lastes fra bunnen og opp med den tyngste komponenten nederst i kabinettet.
- Hvis kabinettet er utstyrt med stabiliseringsutstyr, skal stabilisatorene installeres før montering eller utføring av reparasjonsarbeid på enheten i kabinettet.

**Aviso** Para se prevenir contra danos corporais ao montar ou reparar esta unidade numa estante, deverá tomar precauções especiais para se certificar de que o sistema possui um suporte estável. As seguintes directrizes ajudá-lo-ão a efectuar o seu trabalho com segurança:

- Esta unidade deverá ser montada na parte inferior da estante, caso seja esta a única unidade a ser montada.
- Ao montar esta unidade numa estante parcialmente ocupada, coloque os itens mais pesados na parte inferior da estante, arrumando-os de baixo para cima.
- Se a estante possuir um dispositivo de estabilização, instale-o antes de montar ou reparar a unidade.

**¡Advertencia!** Para evitar lesiones durante el montaje de este equipo sobre un bastidor, o posteriormente durante su mantenimiento, se debe poner mucho cuidado en que el sistema quede bien estable. Para garantizar su seguridad, proceda según las siguientes instrucciones:

- Colocar el equipo en la parte inferior del bastidor, cuando sea la única unidad en el mismo.
- Cuando este equipo se vaya a instalar en un bastidor parcialmente ocupado, comenzar la instalación desde la parte inferior hacia la superior colocando el equipo más pesado en la parte inferior.
- Si el bastidor dispone de dispositivos estabilizadores, instalar éstos antes de montar o proceder al mantenimiento del equipo instalado en el bastidor.

**Varning!** För att undvika kroppsskada när du installerar eller utför underhållsarbete på denna enhet på en ställning måste du vidta särskilda försiktighetsåtgärder för att försäkra dig om att systemet står stadigt. Följande riktlinjer ges för att trygga din säkerhet:

- Om denna enhet är den enda enheten på ställningen skall den installeras längst ned på ställningen.
- Om denna enhet installeras på en delvis fylld ställning skall ställningen fyllas nedifrån och upp, med de tyngsta enheterna längst ned på ställningen.
- Om ställningen är försedd med stabiliseringsdon skall dessa monteras fast innan enheten installeras eller underhålls på ställningen.

**Figyelem** A készülék rackbe történő beszerelése és karbantartása során bekövetkező sérülések elkerülése végett speciális óvintézkedésekkel meg kell őrizni a rendszer stabilitását. A személyes biztonsága érdekében tartsa be a következő szabályokat:

- Ha a rackben csak ez az egy készülék található, a rack aljába kell beszerelni.
- Ha nincs teljesen tele az a rack, amelybe beszerelik a készüléket, alulról fölfelé haladva töltsse fel a racket úgy, hogy a legnehezebb készülék kerüljön a rack aljába.
- Ha stabilizáló eszközök is tartoznak a rackhez, szerelje fel a stabilizátorokat, mielőtt beszerelné az egységet a rackbe, vagy karbantartást végezne rajta.

**Предупреждение** Во избежание травм при монтаже и обслуживании устройства в стойке следует принять особые меры предосторожности, чтобы убедиться в устойчивости оборудования. Для обеспечения безопасности работ необходимо соблюдать следующие правила.

- Если в стойке находится одно устройство, оно должно быть установлено в нижней части.
- При монтаже устройств в частично заполненную стойку устанавливайте оборудование снизу вверх, размещая наиболее тяжелые устройства в нижней части.
- Если стойка снабжена приспособлениями для стабилизации, их необходимо установить до начала монтажа или обслуживания оборудования.

## Chassis Warning for Rack-Mounting and Servicing

**警告** 为避免在机架中安装或维修该部件时使身体受伤，您必须采取特殊的预防措施确保系统固定。以下是确保安全的原则：

- 如果此部件是机架中唯一的部件，应将其安装在机架的底部。
- 如果在部分装满的机架中安装此部件，请按从下往上的顺序安装各个部件，并且最重的组件应安装在机架的底部。
- 如果机架配有固定装置，请先装好固定装置，然后再在机架中安装或维修部件。

**警告** この装置をラックに設置したり保守作業を行ったりするときは、人身事故を防ぐため、システムが安定しているかどうかを十分に確認する必要があります。次の注意事項に従ってください。

- ラックにこの装置を単独で設置する場合は、ラックの一番下に設置します。
- ラックに別の装置がすでに設置されている場合は、最も重量のある装置を一番下にして、重い順に下から上へ設置します。
- ラックに安定器具が付属している場合は、その安定器具を取り付けてから、装置をラックに設置するか、またはラック内の装置の保守作業を行ってください。

**تحذير** لتجنب حدوث أي إصابات عند تركيب هذه الوحدة، يجب اتباع بعض الاحتياطات لضمان عمل النظام بشكل سليم. يتم ذكر الإرشادات التالية لضمان الأمان.

يجب تركيب هذه الوحدة في الجزء السفلي من الدولاب المتضمن قضبان إذا كانت هذه الوحدة هي الوحدة الوحيدة في الدولاب الذي يحتوي على قضبان.

عند تركيب هذه الوحدة في دولاب شبه ممتلئ، قم برفع الدولاب من الجزء السفلي لأعلى بحيث يكون الجزء الأثقل وزناً أسفل الدولاب.

إذا كان الدولاب المتضمن قضباناً يحتوي على أجهزة حفظ التوازن، قم بتثبيت هذه الأجهزة قبل تركيب الوحدة في الدولاب.



- Upozorenje** Kako ne bi došlo do tjelesnih ozljeda kod postavljanja ili servisiranja uređaja na polici, potrebno je poduzeti mjere predostrožnosti kako bi sustav uvijek bio stabilan. Sigurnost se može osigurati poštivanjem sljedećih smjernica:
- Ovaj uređaj treba ugraditi na dno police, ukoliko je to jedini uređaj na polici.
  - Kod ugradnje uređaja u policu na kojoj se već nalaze drugi uređaji, policu treba opremiti počevši od dna, te tako da se na dno stave najteži dijelovi.
  - Ukoliko su na polici ugrađeni stabilizatori, njih montirajte prije ugradnje ili servisiranja uređaja na polici.
- Upozornění** Abyste předešli poranění osob při montáži nebo opravě zařízení v montážním rámu, musíte dodržovat zvláštní preventivní opatření pro zajištění udržení stability systému. Pro zajištění bezpečnosti obsluhy jsou určeny následující zásady:
- Pokud je toto zařízení jedinou jednotkou v montážním rámu, musí být namontováno na nejnižší místo rámu.
  - Pokud je toto zařízení montováno do částečně obsazeného montážního rámu, obsazujte montážní rám ve směru zdola nahoru tak, aby byla nejtěžší součást nejnižší.
  - Pokud je montážní rám vybaven stabilizačními zařízeními, nainstalujte stabilizátory ještě před montáží nebo opravou zařízení v montážním rámu.
- Προειδοποίηση** Για να αποφύγετε τον τραυματισμό κατά την τοποθέτηση ή τη συντήρηση αυτής της συσκευής σε αρθρωτό σύστημα, πρέπει να λάβετε ειδικές προφυλάξεις για να διασφαλίσετε τη σταθερότητα του συστήματος. Οι παρακάτω οδηγίες παρέχονται για να εξασφαλίσουν την ασφάλειά σας:
- Αυτή η συσκευή πρέπει να τοποθετείται στο κάτω μέρος του αρθρωτού συστήματος αν είναι η μοναδική συσκευή σε αυτό.
  - Όταν τοποθετείτε αυτήν τη συσκευή σε εν μέρει γεμάτο αρθρωτό σύστημα, τοποθετήστε συσκευές στο αρθρωτό σύστημα από κάτω προς τα επάνω, με τη βαρύτερη συσκευή στο κάτω μέρος του συστήματος.
  - Εάν το αρθρωτό σύστημα διαθέτει διατάξεις σταθεροποίησης, τοποθετήστε τους σταθεροποιητές πριν τοποθετήσετε ή συντηρήσετε τη συσκευή στο αρθρωτό σύστημα.

**Figyelem** A készülék rackbe történő beszerelése és karbantartása során bekövetkező sérülések elkerülése végett speciális óvintézkedésekkel meg kell őrizni a rendszer stabilitását. A személyes biztonsága érdekében tartsa be a következő szabályokat:

- Ha a rackben csak ez az egy készülék található, a rack aljába kell beszerelni.
- Ha nincs teljesen tele az a rack, amelybe beszerelik a készüléket, alulról fölfelé haladva töltsse fel a racket úgy, hogy a legnehezebb készülék kerüljön a rack aljába.
- Ha stabilizáló eszközök is tartoznak a rackhez, szerelje fel a stabilizátorokat, mielőtt beszerelné az egységet a rackbe, vagy karbantartást végezne rajta.

**Предупреждение** Во избежание травм при монтаже и обслуживании устройства в стойке следует принять особые меры предосторожности, чтобы убедиться в устойчивости оборудования. Для обеспечения безопасности работ необходимо соблюдать следующие правила.

- Если в стойке находится одно устройство, оно должно быть установлено в нижней части.
- При монтаже устройств в частично заполненную стойку устанавливайте оборудование снизу вверх, размещая наиболее тяжелые устройства в нижней части.
- Если стойка снабжена приспособлениями для стабилизации, их необходимо установить до начала монтажа или обслуживания оборудования.

**警告** 为避免在机架中安装或维修该部件时使身体受伤，您必须采取特殊的预防措施确保系统固定。以下是确保安全的原则：

- 如果此部件是机架中唯一的部件，应将其安装在机架的底部。
- 如果在部分装满的机架中安装此部件，请按从下往上的顺序安装各个部件，并且最重的组件应安装在机架的底部。
- 如果机架配有固定装置，请先装好固定装置，然后再在机架中安装或维修部件。

**警告** この装置をラックに設置したり保守作業を行ったりするときは、人身事故を防ぐため、システムが安定しているかどうかを十分に確認する必要があります。次の注意事項に従ってください。

- ラックにこの装置を単独で設置する場合は、ラックの一番下に設置します。
- ラックに別の装置がすでに設置されている場合は、最も重量のある装置を一番下にして、重い順に下から上へ設置します。
- ラックに安定器具が付属している場合は、その安定器具を取り付けてから、装置をラックに設置するか、またはラック内の装置の保守作業を行ってください。

**تحذير** لتجنب حدوث أي إصابات عند تركيب هذه الوحدة، يجب اتباع بعض الاحتياطات لضمان عمل النظام بشكل سليم. يتم ذكر الإرشادات التالية لضمان الأمان.

يجب تركيب هذه الوحدة في الجزء السفلي من الدولاب المتضمن قضبان إذا كانت هذه الوحدة هي الوحدة الوحيدة في الدولاب الذي يحتوي على قضبان.

عند تركيب هذه الوحدة في دولاب شبه ممتلئ، قم برفع الدولاب من الجزء السفلي لأعلى بحيث يكون الجزء الأثقل وزناً أسفل الدولاب.

إذا كان الدولاب المتضمن قضباناً يحتوي على أجهزة حفظ التوازن، قم بتثبيت هذه الأجهزة قبل تركيب الوحدة في الدولاب.

## Grounded Equipment Warning

- Upozorenje** Kako ne bi došlo do tjelesnih ozljeda kod postavljanja ili servisiranja uređaja na polici, potrebno je poduzeti mjere predostrožnosti kako bi sustav uvijek bio stabilan. Sigurnost se može osigurati poštivanjem sljedećih smjernica:
- Ovaj uređaj treba ugraditi na dno police, ukoliko je to jedini uređaj na polici.
  - Kod ugradnje uređaja u policu na kojoj se već nalaze drugi uređaji, policu treba opremiti počevši od dna, te tako da se na dno stave najteži dijelovi.
  - Ukoliko su na polici ugrađeni stabilizatori, njih montirajte prije ugradnje ili servisiranja uređaja na polici.
- Upozornění** Abyste předešli poranění osob při montáži nebo opravě zařízení v montážním rámu, musíte dodržovat zvláštní preventivní opatření pro zajištění udržení stability systému. Pro zajištění bezpečnosti obsluhy jsou určeny následující zásady:
- Pokud je toto zařízení jedinou jednotkou v montážním rámu, musí být namontováno na nejnižší místo rámu.
  - Pokud je toto zařízení montováno do částečně obsazeného montážního rámu, obsazujte montážní rám ve směru zdola nahoru tak, aby byla nejtěžší součást nejniže.
  - Pokud je montážní rám vybaven stabilizačními zařízeními, nainstalujte stabilizátory ještě před montáží nebo opravou zařízení v montážním rámu.

# Grounded Equipment Warning



Warning

This equipment is intended to be grounded. Ensure that the host is connected to earth ground during normal use. Statement 39

Waarschuwing

Deze apparatuur hoort geaard te worden. Zorg dat de host-computer tijdens normaal gebruik met aarde is verbonden.

<b>Varoitus</b>	<b>Tämä laitteisto on tarkoitettu maadoitettavaksi. Varmista, että isäntälaitte on yhdistetty maahan normaalikäytön aikana.</b>
<b>Attention</b>	<b>Cet équipement doit être relié à la terre. S'assurer que l'appareil hôte est relié à la terre lors de l'utilisation normale.</b>
<b>Warnung</b>	<b>Dieses Gerät muß geerdet werden. Stellen Sie sicher, daß das Host-Gerät während des normalen Betriebs an Erde gelegt ist.</b>
<b>Avvertenza</b>	<b>Questa apparecchiatura deve essere collegata a massa. Accertarsi che il dispositivo host sia collegato alla massa di terra durante il normale utilizzo.</b>
<b>Advarsel</b>	<b>Dette utstyret skal jordes. Forviss deg om vertsterminalen er jordet ved normalt bruk.</b>
<b>Aviso</b>	<b>Este equipamento deverá estar ligado à terra. Certifique-se que o host se encontra ligado à terra durante a sua utilização normal.</b>
<b>¡Advertencia!</b>	<b>Este equipo debe conectarse a tierra. Asegurarse de que el equipo principal esté conectado a tierra durante el uso normal.</b>
<b>Varning!</b>	<b>Denna utrustning är avsedd att jordas. Se till att värdenheten är jordad vid normal användning.</b>
<b>Figyelem</b>	<b>A készüléket védőföldeléssel kell ellátni. Győződjön meg róla, hogy a készülék normál használat során csatlakozik a földhöz.</b>
<b>Предупреждение</b>	<b>Данное устройство должно быть заземлено. Убедитесь, что при обычной работе устройство заземлено.</b>
<b>警告</b>	<b>此设备应该接地。请确保主机在正常使用期间连接接地。</b>
<b>警告</b>	<b>この装置はアースに接続するものです。通常の使用では、ホストがアース端子に接続されていることを確認してください。</b>

# Qualified Personnel Warning



## Warning

**Only trained and qualified personnel should be allowed to install or replace this equipment.** Statement 49

## Waarschuwing

**Installatie en reparaties mogen uitsluitend door getraind en bevoegd personeel uitgevoerd worden.**

## Varoitus

**Ainoastaan koulutettu ja pätevä henkilökunta saa asentaa tai vaihtaa tämän laitteen.**

## Avertissement

**Tout installation ou remplacement de l'appareil doit être réalisé par du personnel qualifié et compétent.**

## Achtung

**Gerät nur von geschultem, qualifiziertem Personal installieren oder auswechseln lassen.**

## Avvertenza

**Solo personale addestrato e qualificato deve essere autorizzato ad installare o sostituire questo apparecchio.**

## Advarsel

**Kun kvalifisert personell med riktig opplæring bør montere eller bytte ut dette utstyret.**

## Aviso

**Este equipamento deverá ser instalado ou substituído apenas por pessoal devidamente treinado e qualificado.**

## ¡Atención!

**Estos equipos deben ser instalados y reemplazados exclusivamente por personal técnico adecuadamente preparado y capacitado.**

## Varning

**Denna utrustning ska endast installeras och bytas ut av utbildad och kvalificerad personal.**

## Figyelem

**A berendezést csak szakképzett személy helyezheti üzembe és cserélheti ki.**

- Предупреждение** Установку и замену этого оборудования может осуществлять только специально обученный квалифицированный персонал.
- 警告** 只有经过培训且具有资格的人员才能安装或更换此设备。
- 警告** この装置の設置または交換は、訓練を受けた相応の資格のある人のみが行ってください。
- 

## Restricted Area



### Warning

**This unit is intended for installation in restricted access areas. A restricted access area can be accessed only through the use of a special tool, lock and key, or other means of security.** Statement 1017

### Waarschuwing

**Deze eenheid is bestemd voor installatie in plaatsen met beperkte toegang. Toegang tot een dergelijke plaats kan alleen verkregen worden door middel van een speciaal instrument, een slot en sleutel of een ander veiligheidsmiddel.**

### Varoitus

**Tämä laite on tarkoitettu asennettavaksi paikkaan, johon pääsy on rajoitettua. Tällaiseen paikkaan pääsee vain erikoistyökäluä, lukkoon sopivaa avainta tai jotakin muuta turvalaitetta käyttämällä.**

### Attention

**Cet appareil est à installer dans des zones d'accès réservé. L'accès à une zone d'accès réservé n'est possible qu'en utilisant un outil spécial, un mécanisme de verrouillage et une clé, ou tout autre moyen de sécurité.**

### Warnung

**Diese Einheit ist zur Installation in Bereichen mit beschränktem Zutritt vorgesehen. Der Zutritt zu derartigen Bereichen ist nur mit einem Spezialwerkzeug, Schloss und Schlüssel oder einer sonstigen Sicherheitsvorkehrung möglich.**

■ Restricted Area

- Avvertenza** Questa unità è prevista per essere installata in un'area ad accesso limitato, vale a dire un'area accessibile solo mediante l'uso di un attrezzo speciale, come lucchetto e chiave, o altri dispositivi di sicurezza.
- Advarsel** Denne enheten er beregnet på installasjon i områder med begrenset tilgang. Et begrenset tilgangsområde kan bare nås ved hjelp av et spesielt verktøy, lås og nøkkel, eller andre sikkerhetsanordninger.
- Aviso** Esta unidade foi concebida para instalação em áreas de acesso restrito. Uma área de acesso restrito é uma área à qual apenas tem acesso o pessoal de serviço autorizado, que possua uma ferramenta, chave e fechadura especial, ou qualquer outra forma de segurança.
- ¡Advertencia!** Esta unidad ha sido diseñada para instalación en áreas de acceso restringido. Sólo puede obtenerse acceso a una de estas áreas mediante la utilización de una herramienta especial, cerradura con llave u otro medio de seguridad.
- Varning!** Denna enhet är avsedd för installation i områden med begränsat tillträde. Ett område med begränsat tillträde kan endast tillträdas med hjälp av specialverktyg, lås och nyckel eller annan säkerhetsanordning.
- Figyelem** A készülék korlátozottan hozzáférhető területre történő beszerelésre készült. A korlátozottan hozzáférhető területekhez csak speciális szerszám, zár és kulcs vagy más biztonsági berendezés segítségével lehet hozzáférni.
- Предупреждение** Данное устройство предназначено для установки в помещениях с ограниченным доступом. В такие помещения можно попасть, только имея специальное устройство доступа, карту или ключ или пройдя проверку другими средствами обеспечения безопасности.
- 警告** 此部件应安装在限制进出的场所。限制进出的场所指只能通过使用特殊工具、锁和钥匙或其它安全手段进出的场所。
- 警告** この装置は立ち入り制限区域内に設置することが前提になっています。立ち入り制限区域とは、鍵、錠、またはその他の保全手段を使用しないと立ち入ることができない区域です。



تحذير تم تخصيص هذه الوحدة ليتم تثبيتها في مناطق محظور الوصول إليها. يمكن الوصول إلى المنطقة المحظورة فقط من خلال استخدام أداة خاصة أو قفل أو مفتاح أو أي وسيلة أخرى من التأمين.

**Upozorenje** Uređaj je namijenjen ugradnji na teško dostupnim mjestima. Teško su dostupna mjesta takva mjesta koja su dostupna samo uz pomoć posebnih alata, lokota i ključa, ili nekog drugog načina osiguravanja sigurnosti.

**Upozornění** Toto zařízení je určeno pro instalaci v prostorech s omezeným přístupem. Do prostoru s omezeným přístupem lze získat přístup pouze pomocí zvláštního nástroje, zámku a klíče nebo jiných zabezpečovacích prostředků.

**Προειδοποίηση** Αυτή η συσκευή προορίζεται για να τοποθετηθεί σε χώρους στους οποίους η πρόσβαση είναι περιορισμένη. Η πρόσβαση σε ένα χώρο με περιορισμένη πρόσβαση είναι δυνατή μόνο με τη χρήση ενός ειδικού εργαλείου, κλειδαριάς και κλειδιού ή άλλου μέσου ασφαλείας.

**Figyelem** A készülék korlátozottan hozzáférhető területre történő beszerelésre készült. A korlátozottan hozzáférhető területekhez csak speciális szerszám, zár és kulcs vagy más biztonsági berendezés segítségével lehet hozzáférni.

**Предупреждение** Данное устройство предназначено для установки в помещениях с ограниченным доступом. В такие помещения можно попасть, только имея специальное устройство доступа, карту или ключ или пройдя проверку другими средствами обеспечения безопасности.

**警告** 此部件应安装在限制进出的场所。限制进出的场所指只能通过使用特殊工具、锁和钥匙或其它安全手段进出的场所。

**警告** この装置は立ち入り制限区域内に設置することが前提になっています。立ち入り制限区域とは、鍵、錠、またはその他の保全手段を使用しないと立ち入ることができない区域です。

تحذير تم تخصيص هذه الوحدة ليتم تثبيتها في مناطق محظور الوصول إليها. يمكن الوصول إلى المنطقة المحظورة فقط من خلال استخدام أداة خاصة أو قفل أو مفتاح أو وسيلة أخرى من التأمين.

**Upozorenje** Uređaj je namijenjen ugradnji na teško dostupnim mjestima. Teško su dostupna mjesta takva mjesta koja su dostupna samo uz pomoć posebnih alata, lokota i ključa, ili nekog drugog načina osiguravanja sigurnosti.

**Upozornění** Toto zařízení je určeno pro instalaci v prostorech s omezeným přístupem. Do prostoru s omezeným přístupem lze získat přístup pouze pomocí zvláštního nástroje, zámku a klíče nebo jiných zabezpečovacích prostředků.

## Chassis Power Connection



### Warning

Before connecting or disconnecting ground or power wires to the chassis, ensure that power is removed from the DC circuit. To ensure that all power is OFF, locate the circuit breaker on the panel board that services the DC circuit, switch the circuit breaker to the OFF position, and tape the switch handle of the circuit breaker in the OFF position. Statement 140

### Waarschuwing

Voordat u aarddraden of elektriciteitsdraden op het frame aansluit of van het frame neemt, dient u te controleren of de stroom naar het gelijkstroomcircuit uitgeschakeld is. Om u ervan te verzekeren dat alle stroom UIT is geschakeld, kiest u op het schakelbord de stroomverbreker die het gelijkstroomcircuit bedient, draait de stroomverbreker naar de UIT positie en plakt de schakelaarhendel van de stroomverbreker met plakband in de UIT positie vast.

<b>Varoitus</b>	<b>Varmista, että tasavirtapiirissä ei ole virtaa ennen maadoitus- tai virtajohtojen kytkemistä asennuspohjaan tai ennen niiden irrottamista. Varmistaaksesi, että virta on KATKAISTU täysin, paikanna tasavirrasta huolehtivassa kojetaulussa sijaitseva suojakytkin, käännä suojakytkin KATKAISTU-asentoon ja teippaa suojakytkimen varsi niin, että se pysyy KATKAISTU-asennossa.</b>
<b>Attention</b>	<b>Avant de connecter ou de déconnecter les câbles d'alimentation (pôles et terre) du châssis, vérifiez que le circuit de courant continu est hors tension : localisez le disjoncteur sur le panneau de commande du circuit de courant continu, poussez-le sur la position fermée (OFF) et, à l'aide d'un ruban adhésif, bloquez sa poignée sur cette position.</b>
<b>Warnung</b>	<b>Gleichstrom-Unterbrechung Bevor Sie Erdungs- oder Stromkabel an das Chassis anschließen oder von ihm abtrennen, ist sicherzustellen, daß der Gleichstrom-Stromkreis unterbrochen ist. Um sicherzustellen, daß sämtlicher Strom AUS ist, machen Sie auf der Schalttafel den Unterbrecher für die Gleichstromschaltung ausfindig, stellen Sie den Unterbrecher auf OFF, und kleben Sie den Schaltergriff des Unterbrechers mit Klebeband in der AUS-Stellung fest.</b>
<b>Avvertenza</b>	<b>Prima di collegare o distaccare i cavi elettrici o di messa a terra dallo chassis, assicuratevi che il circuito DC non sia alimentato. Per verificare che tutta l'alimentazione sia scollegata (OFF), individuare l'interruttore automatico sul quadro strumenti che alimenta il circuito CC, mettere l'interruttore in posizione OFF e fissarlo con nastro adesivo in tale posizione.</b>
<b>Advarsel</b>	<b>Før til- eller frakobling av jord- og strømløsnings til kabinettet, kontroller at strømmen er frakoblet likestrømkretsen. Sørg for at all strøm er slått AV. Dette gjøres ved å lokalisere strømbryteren på brytertavlen som betjener likestrømkretsen, slå strømbryteren AV og teipe bryterhåndtaket på strømbryteren i AV-stilling.</b>
<b>Aviso</b>	<b>Antes de conectar ou desconectar a ligação à terra ou a alimentação do chassis, certifique-se de que desligou a fonte de alimentação de energia do circuito de corrente contínua. Para se assegurar que toda a corrente foi DESLIGADA, localize o disjuntor no painel que serve o circuito de corrente contínua e coloque-o na posição OFF (Desligado), segurando nessa posição a manivela do interruptor do disjuntor com fita isoladora.</b>

**¡Advertencia!** Antes de conectar o desconectar el circuito de tierra o de alimentación del chasis, asegúrese que la alimentación del circuito CC esté cortada (OFF). Para asegurarse de que toda la alimentación esté cortada (OFF), localice el interruptor automático en el panel que alimenta el circuito de corriente continua, cambie el interruptor automático a la posición de apagado (OFF) y sujete con cinta la palanca del interruptor automático en posición de apagado (OFF).

**Varning!** Innan du kopplar jord- eller elledningar till eller från chassit måste du kontrollera att strömförsörjningen till likströmskretsen är bruten. Kontrollera att all strömförsörjning är BRUTEN genom att slå AV det överspänningsskydd som skyddar likströmskretsen och tejpa fast överspänningsskyddets omkopplare i FRÅN-läget.

**Figyelem** Mielőtt a föld- vagy a fázisvezetéket a házhoz csatlakoztatja, feltétlenül szakítsa meg az egyenáramú áramkör tápellátását. Úgy gondoskodhat arról, hogy mindenféle tápellátás meg legyen szakítva, hogy megkeresi az árammegszakítót az egyenáramú áramkört kiszolgáló kártyán, az árammegszakítót OFF (KI) helyzetbe állítja, és árammegszakító kapcsolóját az OFF (KI) helyzetben leragasztja.

**Предупреждение** Перед подключением к шасси проводов заземления или питания необходимо убедиться в том, что питание в цепи постоянного тока отключено. Чтобы убедиться в том, что питание полностью ОТКЛЮЧЕНО, найдите на панели выключатель цепи постоянного тока, установите его в положение ВЫКЛ и закрепите рычажок переключателя в этом положении

**警告** 将接地线或电源线连接到底盘或从底盘上断开前，应确保电源已与直流电路断开。为了确保所有电源均处于“关闭”状态，须找到控制直流电路面板上的断路器，将断路器切换到“关闭”位置，并用胶带将断路器的开关手柄固定在“关闭”位置上。

**警告** シャーシヘアース端子または電源コードを接続したり、切断したりする場合、DC回路から電源がはずれていることを確認してください。すべての電源がオフになっていることを確認する際は、DC回路をサポートするパネルボード上に回路ブレーカを設置し、回路ブレーカのスイッチをオフにし、回路ブレーカのスイッチハンドルをオフの位置に接着します。

# Exposed DC Power Wire Warning

**Warning**

An exposed wire lead from a DC-input power source can conduct harmful levels of electricity. Be sure that no exposed portion of the DC-input power source wire extends from the terminal block plug. Statement 122

**Waarschuwing**

Een blootgestelde verbindingsdraad van een ingangsgelijkstroombron kan gevaarlijke elektriciteitsniveaus geleiden. Zorg ervoor dat geen blootgesteld deel van het draad van de ingangsgelijkstroombron zich uitstrekt vanuit het aansluitblok van de terminal.

**Varoitus**

Tasavirtalähteestä tuleva avoin johto voi johtaa vaarallisen määrän sähköä. Varmista, ettei kaapelikengän pistokkeesta tule esille lainkaan tasavirtajohdon avointa osaa.

**Attention**

Pour éviter tout risque de choc électrique, vérifiez que les câbles d'alimentation secteur sont protégés par une gaine. Aucun fil dénudé ne doit apparaître hors du bloc d'alimentation du terminal.

**Warnung**

Eine ungeschützte Kabelleitung von einer Gleichstrom-Eingangsspannungsquelle kann schädliche Elektrizitätslevel führen. Achten Sie darauf, daß von dem Klemmleistenstecker aus kein ungeschütztes Eingangsgleichstromkabel freiliegt.

**Avvertenza**

Un cavo elettrico scoperto proveniente da un alimentatore DC-INPUT può trasmettere scariche elettriche ad elevata tensione. Assicuratevi che i cavi in uscita dall'alimentatore DC-input non presentino punti scoperti.

**Advarsel**

En avdekket ledning fra en likestrømskilde kan lede farlig elektrisitet. Kontroller at ingen avdekkede deler av ledningen til likestrømskilden stikker ut av terminalens koblingsblokk.

**Aviso**

Um fio condutor exposto de uma unidade de entrada de DC (corrente contínua) pode transportar níveis perigosos de electricidade. Certifique-se de que nenhuma secção exposta de um fio condutor da fonte de energia de entrada de DC se estende a partir da ficha da placa de terminais.

**¡Advertencia!** **Un cable desnudo de una fuente de entrada de alimentación de corriente directa (DC) puede conducir niveles de electricidad peligrosos. Asegúrese de que ninguna parte del cable de la fuente de alimentación de DC de entrada sale del enchufe del bloque de terminal.**

**Varning!** **En blottad trådledning från en likströmsförsörjningsenhet kan utgöra en ledare för skadliga elektricitetsnivåer. Se till att inte någon blottad ledningsdel från likströmsförsörjningsenheten sticker ut från stiftplinten.**

**Figyelem** **Az egyenáramú tápegység egyik hozzáférhető vezetéke veszélyes áramerősségű lehet. Győződjön meg róla, hogy az egyenáramú tápegység egyik vezetéke sem lóg ki a sorkapocsból.**

**Предупреждение** **Неизолированный провод, который выходит из источника питания постоянного тока, может нести опасный уровень заряда. Убедитесь, что провод входного источника питания постоянного тока, который выходит из вилки контактной колодки, надежно изолирован.**

**警告** **从 DC 输入电源裸露的引线可能会造成电击伤害。请确保 DC 输入电源线没有任何裸露部份从端子板插头伸展出来。**

**警告** **DC 入力電源装置からの露出したリード線は、危険な電気を伝導することがあります。DC 入力電源装置からの配線の露出部分が、端子ブロックのプラグからはみ出していないかどうかを確認してください。**



---

## Numerics

### 10/100/1000 ports

- cable lengths [3-8, 4-11](#)
- connecting to [3-62 to 3-64, 4-47 to 4-49](#)
- described [2-7](#)
- pinouts [B-2](#)

### 10/100 ports

- cable lengths [3-8, 4-11](#)
- connecting to [3-62 to 3-64, 4-47 to 4-49](#)
- described [2-6 to 2-7](#)
- pinouts [B-2](#)

### 100BASE-FX ports

- cable lengths [3-8, 4-11](#)
- connecting to [3-65 to 3-66, 4-50 to 4-51](#)
- connectors and cables [B-3](#)
- described [2-8](#)
- power levels, fiber-optic [A-3](#)

### 100BASE-LX ports

- cable lengths [3-8, 4-11](#)
- connecting to [3-67 to 3-68, 4-52 to 4-54](#)
- connectors and cables [B-3](#)
- described [2-8](#)

---

## A

### AC power

- connecting to [3-29 to 3-40](#)

### adapter pinouts, terminal

- RJ-45-to-DB-25 [B-10](#)
- RJ-45-to-DB-9 [B-9](#)

### airflow

- required clearance [3-9, 4-11](#)

### alarm relay connections

- power and relay connector [2-8, 2-9](#)

### alarms and relays

- LEDs [2-16](#)

### altitude [A-2, A-4](#)

### applying the switch protective liner [3-10, 4-13](#)

### autonegotiation

- 10/100/1000 ports [2-7](#)
- 10/100 ports [2-7](#)

---

## C

### cables

- 10/100/1000 ports [2-7](#)
- 10/100 ports [2-6 to 2-7](#)
- 100BASE-FX ports [2-8](#)

- 100BASE-LX ports [2-8](#)
- crossover
  - four twisted-pair pinout, 10/100 ports [B-7](#)
  - four twisted-pair pinout, 1000BASE-T ports [B-8](#)
  - identifying [B-11](#)
  - two twisted-pair pinout [B-6](#)
- LC [B-4](#)
- LC patch cables [B-4](#)
- multimode
  - 100BASE-FX ports [2-8](#)
- problems, solving [5-4](#)
- single-mode
  - 100BASE-LX ports [2-8](#)
- straight-through
  - four twisted-pair pinout, 10/100 ports [B-7](#)
  - four twisted-pair pinout, 1000BASE-T ports [B-8](#)
  - two twisted-pair pinout [B-6](#)
- twisted-pair
  - 10/100/1000 ports [2-7](#)
  - 10/100 ports [2-6 to 2-7](#)
- Catalyst 2955C-12 switch
  - illustrated [2-4](#)
  - LEDs
    - illustrated [2-12](#)
- Catalyst 2955S-12 switch
  - illustrated [2-5](#)
  - LEDs
    - illustrated [2-12](#)
- Catalyst 2955 switch
  - warning labels [2-5](#)
- Catalyst 2955T-12 switch
  - illustrated [2-3](#)
  - LEDs
    - illustrated [2-11](#)
  - cautions, defined [xviii](#)
  - chassis power connection warning [C-72](#)
  - chassis warnings
    - servicing [C-39](#)
- Cisco IE2100 [2-20](#)
- Cisco IE2100 Series Configuration Registrar
  - See Cisco IE2100
- Cisco Intelligent Engine 2100
  - See Cisco IE2100
- CiscoView [2-19](#)
- class 1, division 2, hazardous location warning [C-29 to C-31](#)
- Class 1 laser product warning [3-5, 4-7, B-4](#)
- class 1 laser product warning [C-49](#)
- Class 1 LED product warning [3-5, 3-65, 4-7, 4-50, B-3](#)
- class 1 LED product warning [C-50](#)
- clearance [3-9, 4-11](#)
- CLI [2-19](#)
- command-line interface
  - See CLI
- configuration examples, network [2-1](#)



- connecting
    - to 10/100/1000 ports [3-62 to 3-64, 4-47 to 4-49](#)
    - to 10/100 ports [3-62 to 3-64, 4-47 to 4-49](#)
    - to 100BASE-FX ports [3-65 to 3-66, 4-50 to 4-51](#)
    - to 100BASE-LX ports [3-67 to 3-68, 4-52 to 4-54](#)
    - to console port [3-11 to 3-13, 4-14 to 4-16](#)
    - to DC power [3-17 to 3-27, 4-21 to 4-30](#)
    - to PC [3-11 to 3-13, 4-14 to 4-16](#)
    - to terminal [3-11 to 3-13, 4-14 to 4-16](#)
    - to the power converter [3-29 to 3-47](#)
  - connecting to
    - external alarm devices [3-48 to 3-51, 4-32 to 4-36](#)
  - connecting to the console port [1-4](#)
  - connectivity problems, solving [5-5](#)
  - connectors and cables
    - 100BASE-FX ports [B-3](#)
    - 100BASE-LX ports [B-3](#)
    - console port [B-5](#)
  - console cable connection warning [C-24 to C-27](#)
  - console port
    - adapter pinouts
      - RJ-45-to-DB-25 terminal [B-10](#)
    - connecting to [1-4, 3-11 to 3-13, 4-14 to 4-16, B-9 to B-10](#)
    - default characteristics [3-12, 4-15](#)
    - described [2-10](#)
    - RJ-45-to-DB-9 adapter cable pinouts [B-9](#)
  - conventions, document [xviii to xxvi](#)
  - crossover cable [B-11](#)
    - connecting to
      - 10/100/1000 ports [3-63, 4-48](#)
      - 10/100 ports [3-63, 4-48](#)
  - connectivity problems [5-5](#)
  - pinout
    - four twisted-pair, 10/100 ports [B-7](#)
    - four twisted-pair, 1000BASE-T ports [B-8](#)
    - two twisted-pair [B-6](#)
- 
- D**
- DC power
    - connecting to [3-17 to 3-27, 4-21 to 4-30](#)
    - warnings [3-2, 3-17, 4-2, 4-21](#)
  - DC power disconnection warning [3-4, 3-18, 4-6](#)
  - default characteristics of the console port [3-12, 4-15](#)
  - Device Manager [xxvi, 2-19](#)
    - to configure switch [3-69, 4-54](#)
  - dimensions [A-2, A-5](#)
  - documentation
    - related publications [xxvi](#)
  - document conventions [xviii to xxvi](#)
- 
- E**
- electrical noise, avoiding [3-9, 4-12](#)
  - electromagnetic interface (EMI) [A-3, A-5](#)
  - EMC
    - agency approvals [A-3 to A-5](#)

EMC regulatory statements [3-6, 4-8](#)  
 ensure that the switch is grounded warning [3-4, 4-6](#)  
 environmental ranges [A-2, A-4](#)  
 ESD  
   requirements [3-62, 4-47](#)  
 European Zone 2 certification  
   regulatory statements [4-10](#)  
 examples, network configuration [2-1](#)  
 exposed DC power wire warning [3-5, 3-20, 3-33, 3-44, 4-4, 4-23, C-75](#)

---

## F

features [2-1 to 2-2](#)  
 ferrite  
   attaching [3-24 to 3-25, 4-27 to 4-28](#)  
 fiber-port specifications [A-3](#)  
 front panel  
   10/100/1000 ports [2-7](#)  
   10/100 ports [2-6 to 2-7](#)  
   100BASE-FX ports [2-8](#)  
   100BASE-LX ports [2-8](#)  
 clearance [3-9, 4-11](#)  
 console port [2-10](#)  
 described [2-3](#)  
 illustrated [2-3 to 2-5](#)

LEDs [2-10 to 2-16](#)  
 power and relay connector [2-8](#)  
 functional ground lug warning [3-4, 3-15, 3-32, 4-6, 4-18](#)

---

## G

ground connection warning [3-3, 3-15, 3-36, 3-42, 4-5, 4-18, C-42 to C-43](#)  
 grounded equipment warning [C-22 to C-23, C-66](#)  
 grounding procedures [3-15 to 3-17, 4-18 to 4-20](#)

---

## H

hazardous location installation warning [C-7](#)  
 hazardous location warnings  
   connecting and disconnecting cables [1-4, 4-5](#)  
   console cable [1-6, 2-10, 4-5, 4-14, 4-16, 4-30, 5-2](#)  
   disconnecting equipment [4-3](#)  
   power and relay connector [2-9, 4-3, 4-28](#)  
   relay wires [2-16, 4-4, 4-33](#)  
   safe operating voltage range [4-3](#)  
 hot surface warning label  
   illustrated [2-6](#)  
 HP OpenView [2-20](#)  
 humidity [A-2](#)

industrial environment warning [3-3, 4-4](#)

installation

- applying the switch protective liner [3-10, 4-13](#)
- assigning the IP Address [1-6](#)
- attaching the ferrite [3-24 to 3-25, 4-27 to 4-28](#)
- attach the power and relay connector [3-25, 4-28](#)
- connecting to a power source [1-2](#)
- grounding procedures [3-15 to 3-17, 4-18 to 4-20](#)
- guidelines [3-8, 4-11](#)
- mounting on a DIN rail [3-52 to 3-56, 4-37 to 4-41](#)
- package contents [3-9 to 3-10, 4-12 to 4-13](#)
- POST [1-2 to 1-3, 3-27 to 3-29, 4-30 to 4-32](#)
- power on [3-27, 4-30](#)
- pre-installation information and guidelines [3-2 to 3-10, 4-2 to 4-10](#)
- rack-mount [3-57 to 3-58, 4-42 to 4-43](#)
- required clearance [3-9, 4-11](#)
- starting the terminal-emulation software [1-6](#)
- verifying switch operation [3-11 to 3-29, 4-14 to 4-32](#)
- warning [C-3](#)
- wiring the relays [3-48 to 3-51, 4-32 to 4-36](#)

installation instructions warning [C-38](#)

invisible laser radiation warning [3-5, 4-7, B-4](#)

IOS command-line interface [2-19](#)

---

## J

jewelry removal warning [3-4, 4-6, C-45](#)

---

## L

laser beam exposure warning [3-6, 4-7, C-56](#)

laser radiation warning [C-52](#)

laser safety warning label

- illustrated [2-6](#)

laser viewing warning [3-5, 4-7, C-54](#)

LC

- patch cables [B-4](#)

LEDs

- alarm relay [2-16](#)
- alarm relay status [2-16](#)
- front panel [2-10 to 2-16](#)
- port [2-13](#)
- port status [2-13](#)
- uplink ports [2-14 to 2-15](#)
- uplink port status [2-14 to 2-15](#)

lightning activity warning [3-5, 4-7, C-1](#)

---

## M

management options [2-19 to 2-20](#)

mounting

- DIN rail [3-52 to 3-56, 4-37 to 4-41](#)
- rack [3-57 to 3-58, 4-42 to 4-43](#)

## MT-RJ

connector [B-3](#)

---

**N**
Network Assistant [2-19](#)

getting started guide [xxvi](#)

to configure switch [3-69, 4-54](#)

network configuration examples [2-1](#)

noise, electrical [3-9, 4-12](#)

notes, defined [xviii](#)

---

**O**

open type equipment warning [C-18 to C-21](#)

overtemperature warning [3-3, 4-5, C-27](#)

---

**P**

package contents [3-9 to 3-10, 4-12 to 4-13](#)

patch cables, LC [3-10, 4-13](#)

patch cables, MT-RJ [3-10, 3-65, 3-67, 4-13, 4-50, 4-52](#)

PC, connecting to switch [3-11 to 3-13, 4-14 to 4-16, B-9](#)

performance problems, solving [5-4](#)

physical dimensions [A-2, A-5](#)

## pinouts

10/100/1000 ports [B-2](#)

10/100 ports [B-2](#)

adapters [B-11](#)

DB-25 [B-10](#)

## console port

DB-25 adapter [B-10](#)

RJ-45-to-DB-9 adapter cable [B-9](#)

crossover cable [B-11](#)

## crossover cables

four twisted-pair, 10/100 ports [B-7](#)

four twisted-pair, 1000BASE-T ports [B-8](#)

two twisted-pair [B-6](#)

RJ-45-to-DB-25 terminal adapter [B-10](#)

RJ-45-to-DB-9 adapter cable [B-9](#)

RJ-45-to-DB-9 PC adapter cable [B-9](#)

## straight-through cables

four twisted-pair, 10/100 ports [B-7](#)

four twisted-pair, 1000BASE-T ports [B-8](#)

two twisted-pair [B-6](#)

pollution degree 2 industrial environment  
warning [C-33](#)

## port

10/100/1000BASE-T

LEDs [2-14](#)

100BASE-FX

LEDs [2-15](#)

100BASE-LX

LEDs [2-15](#)

LEDs [2-13 to 2-15](#)

port connection warning [C-35 to C-38](#)

- ports
    - 10/100
      - pinouts [B-2](#)
    - 10/100/1000
      - pinouts [B-2](#)
    - See 10/100 ports, 10/100/1000 ports, 100BASE-FX ports, 100BASE-LX ports, and console ports
  - POST
    - description [1-2, 3-27, 3-46, 4-30, 5-2](#)
    - problems [5-5](#)
    - results [1-2, 3-27, 3-46, 4-30, 5-2](#)
  - power
    - connecting to
      - AC [3-29 to 3-40](#)
      - DC [3-17 to 3-27, 4-21 to 4-30](#)
      - power and relay connector [2-8](#)
    - requirements [A-2, A-5](#)
  - power and relay connector
    - connecting to the switch [3-25, 4-28](#)
    - described [2-8](#)
    - illustrated [2-8](#)
  - power and relay connector warning [C-3 to C-6](#)
  - power connection
    - power and relay connector [2-8](#)
  - power on [3-13, 4-16](#)
  - power on the switch [3-27, 4-30](#)
  - procedures
    - connecting to AC power [3-29 to 3-40](#)
    - connecting to DC power [3-17 to 3-27, 4-21 to 4-30](#)
    - installation [3-57 to 3-58, 4-42 to 4-43](#)
    - power on [3-13 to 3-27, 4-16 to 4-26](#)
  - product disposal warning [3-5, 4-7, C-47](#)
  - protective liner
    - applying [3-10, 4-13](#)
  - publications, related [xxvi](#)
- 
- ## Q
- qualified personnel warning [C-68](#)
- 
- ## R
- rack-mounting
    - procedures [3-57 to 3-58, 4-42 to 4-43](#)
  - rear panel
    - clearance [3-9, 4-11](#)
  - regulatory statements, EMC [3-6, 4-8](#)
  - regulatory statements, European Zone 2 certification [4-10](#)
  - related publications [xxvi](#)
  - relays
    - connecting to
      - power and relay connector [2-9](#)
    - described [2-9](#)
    - wiring [3-48 to 3-51, 4-32 to 4-36](#)
  - remove power before disconnecting
    - warning [C-15 to C-18](#)

removing the switch from a DIN rail or a rack [3-59 to 3-61](#), [4-45 to 4-46](#)

removing the switch from parallel and face-down mounted positions [3-59 to 3-61](#), [4-45 to 4-46](#)

restricted area warning [C-69](#)

---

## S

safe operating voltage range  
warning [C-9 to C-10](#)

safety agency approvals [A-3](#), [A-5](#)

safety warnings [3-2 to 3-6](#), [4-2 to 4-7](#), [C-1 to C-76](#)

SELV-IEC 60950 DC power supply  
warning [C-44](#)

service personnel warning [3-2](#), [4-2](#), [C-39](#)

servicing warning [C-58 to C-66](#)

SNMP network management platforms [2-20](#)

software switch management [2-19 to 2-20](#)

specifications [A-1 to A-5](#)

stacking the chassis warning [C-39](#), [C-41 to C-42](#)

straight-through cable

- connecting to
  - 10/100/1000 ports [3-63](#), [4-48](#)
  - 10/100 ports [3-63](#), [4-48](#)
- connectivity problems [5-5](#)
- pinout
  - four twisted-pair, 10/100 ports [B-7](#)
  - four twisted-pair, 1000BASE-T ports [B-8](#)
  - two twisted-pair [B-6](#)

SunNet Manager [2-20](#)

supply wires warning [3-3](#), [3-32](#), [3-42](#), [4-4](#),  
[C-32 to C-33](#)

switch, power-on [3-13 to 3-27](#), [4-16 to 4-30](#)

switch relays warning [C-11 to C-14](#)

---

## T

technical specifications [A-1 to A-5](#)

Telnet, and accessing the CLI [2-19](#)

temperature

- operating [A-2](#), [A-4](#)
- warning [3-3](#), [4-5](#)

terminal, connecting to a switch [3-11 to 3-13](#),  
[4-14 to 4-16](#), [B-10](#)

terminal-emulation software [1-5](#), [3-12](#), [4-15](#)

translated warnings [C-1 to C-76](#)

troubleshooting [5-1](#)

- diagnosing problems [5-3 to 5-5](#)
- understanding POST results [5-2](#)

---

## U

uplink ports

- LEDs [2-14 to 2-15](#)

**V**

verifying package contents [3-9 to 3-10](#),  
[4-12 to 4-13](#)

verifying switch operation [3-11 to 3-29](#),  
[4-14 to 4-32](#)

**W**

warning labels

hot surface [2-6](#)

illustrated [2-5](#)

laser safety [2-6](#)

warnings

chassis power connection [C-72](#)

Class 1 laser product [3-5, 4-7, B-4](#)

class 1 laser product [C-49](#)

Class 1 LED product [3-5, 3-65, 4-7, 4-50, B-3](#)

class 1 LED product [C-50](#)

console cable connection [C-24 to C-27](#)

DC power [3-2, 3-17, 4-2, 4-21](#)

ensure that the switch is grounded [3-4, 4-6](#)

exposed DC power wire [C-75](#)

functional ground lug [3-4, 3-15, 3-32, 4-6, 4-18](#)

ground connection [3-3, 4-5, C-42 to C-43](#)

grounded equipment [C-22 to C-23, C-66](#)

hazardous locations

- class 1, division 2 hazardous location [C-29 to C-31](#)

connecting and disconnecting cables [1-4, 4-5](#)

console cable [1-6, 2-10, 4-5, 4-14, 4-16, 4-30, 5-2](#)

disconnecting equipment [4-3](#)

pollution degree 2 industrial environment [C-33](#)

port connection [C-35 to C-38](#)

power and relay connector [2-9, 4-3, 4-28](#)

relay wires [2-16, 4-4, 4-33](#)

safe operating voltage range [4-3](#)

switch installation [C-7](#)

industrial environment [3-3, 4-4](#)

installation [3-2 to 3-6, 4-2 to 4-7, C-3](#)

installation instructions [C-38](#)

invisible laser radiation [3-5, 4-7, B-4](#)

jewelry removal [3-4, 4-6, C-45](#)

laser beam exposure [3-6, 4-7, C-56](#)

laser radiation [C-52](#)

laser viewing [3-5, 4-7, C-54](#)

lightning activity [3-5, 4-7, C-1](#)

open type equipment [C-18 to C-21](#)

overtemperature [3-3, 4-5, C-27](#)

product disposal [3-5, 4-7, C-47](#)

qualified personnel [C-68](#)

remove power before disconnecting [C-15 to C-18](#)

restricted area [C-69](#)

SELV-IEC 60950 DC power supply [C-44](#)

service personnel [3-2, 4-2, C-39](#)

servicing [C-39, C-58 to C-66](#)

stacking the chassis [C-39, C-41 to C-42](#)

supply wires [3-3](#), [3-32](#), [3-42](#), [4-4](#), [C-32 to C-33](#)  
temperature [3-3](#)  
translated [C-1 to C-76](#)  
wiring the relays [3-48 to 3-51](#), [4-32 to 4-36](#)