



# Installation in a Hazardous Environment

---

This chapter describes how to install your switch in a hazardous environment, interpret the power-on self-test (POST), and connect the switch to other devices. Read these topics, and perform the procedures in this order:

- [Preparing for Installation, page 3-2](#)
- [Verifying Switch Operation, page 3-12](#)
- [Installing the Switch on a DIN Rail, page 3-32](#)
- [Installing the Switch in a Rack, page 3-36](#)
- [Removing the Switch from a DIN Rail or a Rack, page 3-39](#)
- [Connecting to 10/100 and 10/100/1000 Ports, page 3-42](#)
- [Connecting to 100BASE-FX MM Ports, page 3-45](#)
- [Connecting to 100BASE-LX SM Ports, page 3-47](#)
- [Where to Go Next, page 3-50](#)

# Preparing for Installation

This section provides information about these topics:

- [Warnings, page 3-2](#)
- [EMC Regulatory Statements, page 3-7](#)
- [Installation Guidelines, page 3-10](#)
- [Verifying Package Contents, page 3-11](#)

## Warnings

These warnings are translated into several languages in [Appendix C, “Translated Safety Warnings.”](#)



Warning

---

**This equipment is to be installed and maintained by service personnel only as defined by AS/NZS 3260 Clause 1.2.14.3 Service Personnel.**

---



Warning

---

**Read the installation instructions before you connect the system to its power source.**

---



Warning

---

**Do not disconnect connections to this equipment unless power has been removed or you have verified that the area is nonhazardous. Secure any external connections that mate to this equipment by using screws, sliding latches, threaded connectors, or other means provided with this product.**

---

**Substitution of components may impair suitability for Class I, Division 2.**

---



Warning

When you connect or disconnect the power and relay connector with power applied, an electrical arc can occur. This could cause an explosion in hazardous area installations. Be sure that power is removed from the switch and alarm circuit. Be sure that power cannot be accidentally turned on or verify that the area is nonhazardous before proceeding.

Failure to securely tighten the power and relay connector captive screws can result in an electrical arc if the connector is accidentally removed.



Warning

Connect the unit only to DC power source that complies with the safety extra-low voltage (SELV) requirements in IEC 60950 based safety standards.



Warning

The nominal voltage for this product is 24 V. When the switch is installed in hazardous locations, the safe operating range of 18 to 30 VDC must be maintained.



Warning

The switch relays are rated at 1 Amp and have a voltage limit of 30 VDC and 0.3 Amp at a voltage limit of 125 VAC. It is dangerous to exceed these limitations in a hazardous environment.

An electrical arc can occur when you connect or disconnect the relay wires with field side power applied. This could cause an explosion in switch installations in a hazardous location. Before proceeding, be sure that power is removed or the area is not hazardous.



Warning

This equipment is intended for use in a Pollution Degree 2 industrial environment, in overvoltage Category II applications (as defined in IEC publication 60664-1), and at altitudes up to 2000 meters without derating.



Warning

---

This equipment is supplied as “open type” equipment. It must be mounted within an enclosure that is suitably designed for those specific environmental conditions that will be present and appropriately designed to prevent personal injury resulting from accessibility to live parts. The interior of the enclosure must be accessible only by the use of a tool.

The enclosure must meet IP 54 or NEMA type 4 minimum enclosure rating standards.

---



Warning

---

Use twisted-pair supply wires suitable for 86°F (30°C) above surrounding ambient temperature outside the enclosure.

---



Warning

---

When used in a Class I, Division 2, hazardous location, this equipment must be mounted in a suitable enclosure with a proper wiring method that complies with the governing electrical codes.

---



Warning

---

In switch installations in a hazardous location, the DC power source could be located away from the vicinity of the switch. be sure that power is removed and power cannot be accidentally be turned on or the area is nonhazardous before proceeding.

---



Warning

If you connect or disconnect the console cable with power applied to the switch or any device on the network, an electrical arc can occur. This could cause an explosion in hazardous location installations. Be sure that power is removed or the area is nonhazardous before proceeding.

To verify switch operation, perform POST on the switch in a nonhazardous location before installation.



Warning

Do not connect or disconnect cables to the ports while power is applied to the switch or any device on the network because an electrical arc can occur. This could cause an explosion in hazardous location installations. Be sure that power is removed from the switch and cannot be accidentally be turned on, or verify that the area is nonhazardous before proceeding.



Warning

To prevent the switch from overheating, do not operate it in an area that exceeds the maximum recommended ambient temperature of 140°F (60°C). To prevent airflow restriction, allow at least 3 inches (7.6 cm) of clearance around the ventilation openings.



Warning

When used in a Class I, Division 2, hazardous location, this equipment must be mounted in a suitable enclosure with proper wiring method, for all power, input and output wiring, that complies with the governing electrical codes and in accordance with the authority having jurisdiction over Class I, Division 2 installations.



Warning

When used in a Class I, Division 2, hazardous location, this equipment must be mounted in a suitable enclosure with a proper wiring method that complies with the governing electrical codes.



Warning

Do not stack the chassis on any other equipment. If the chassis falls, it can cause severe bodily injury and equipment damage.



Warning

---

When installing the unit, always make the ground connection first and disconnect it last.

---



Warning

---

This equipment is intended to be grounded. Ensure that the host is connected to earth ground during normal use.

---



Warning

---

This equipment is intended to be grounded to comply with emission and immunity requirements. Ensure that the switch functional ground lug is connected to earth ground during normal use.

---



Warning

---

Before working on equipment that is connected to power lines, remove jewelry (including rings, necklaces, and watches). Metal objects will heat up when connected to power and ground and can cause serious burns or weld the metal object to the terminals.

---



Warning

---

Do not work on the system or connect or disconnect cables during periods of lightning activity.

---



Warning

---

Ultimate disposal of this product should be handled according to all national laws and regulations.

---



Warning

---

Class 1 laser product

---



Warning

---

Class 1 LED product

---



Warning

---

Invisible laser radiation may be emitted from disconnected fibers or connectors. Do not stare into beams or view directly with optical instruments.

---



Warning

---

For diverging beams, viewing the laser output with certain optical instruments within a distance of 100 mm may harm your eyes. For collimated beams, viewing the laser output with certain optical instruments designed for use at a distance may harm your eyes.

---



Warning

---

Laser radiation is present when the system is open.

---



Warning

---

LED radiation is present when the system is open.

---



Warning

---

Avoid exposure to the laser beam.

---

## EMC Regulatory Statements

This section includes specific regulatory statements about the Catalyst 2955 switches.

### U.S.A.

This equipment is considered Group 1, Class A industrial equipment according to IEC/CISPR Publication 11. Without appropriate precautions, there may be potential difficulties ensuring electromagnetic compatibility in other environments due to conducted as well as radiated disturbance.

Group 1 contains all Industrial, Scientific and Medical (ISM) equipment in which there is intentionally generated and/or used conductively coupled radio-frequency energy which is necessary for the internal functioning of the equipment itself.

Class A equipment is suitable for use in all establishments other than domestic and those directly connected to a low voltage power supply network which supplies buildings used for domestic purposes.

Additional U.S. regulatory information for this product is in the front matter of this manual.

## Taiwan

This is a Class A Information product. When used in a residential environment, it may cause radio frequency interference. Under such circumstances, the user may be requested to take appropriate countermeasures.

警告使用者：  
這是甲類的資訊產品，在居住的環境中使用時，可能會造成射頻干擾，在這種情況下，使用者會被要求採取某些適當的對策。

## Japan

This is a Class A product based on the standard of the Voluntary Control Council for Interference by Information Technology Equipment (VCCI). If this equipment is used in a domestic environment, radio disturbance may arise. When such trouble occurs, the user may be required to take corrective actions.

この装置は、情報処理装置等電波障害自主規制協議会（VCCI）の基準に基づくクラスA情報技術装置です。この装置を家庭環境で使用すると電波妨害を引き起こすことがあります。この場合には使用者が適切な対策を講ずるよう要求されることがあります。

146464



## Korea



Warning

**This is a Class A Device and is registered for EMC requirements for industrial use. The seller or buyer should be aware of this. If this type was sold or purchased by mistake, it should be replaced with a residential-use type.**

주의 A급 기기 이 기기는 업무용으로 전자파 적합 등록을 한 기기이  
오니 판매자 또는 사용자는 이 점을 주의하시기 바라며 만약  
잘못 판매 또는 구입하였을 때에는 가정용으로 교환하시기 바랍니다.

## Hungary

This equipment is a Class A product and should be used and installed properly according to the Hungarian EMC Class A requirements (MSZEN55022). Class A equipment is designed for typical commercial establishments for which special conditions of installation and protection distance are used.

Figyelmeztetés a felhasználói kézikönyv számára:

Ez a berendezés "A" osztályú termék, felhasználására és üzembe helyezésére a magyar EMC "A" osztályú követelményeknek (MSZ EN 55022) megfelelően kerülhet sor, illetve ezen "A" osztályú berendezések csak megfelelő kereskedelmi forrásból származhatnak, amelyek biztosítják a megfelelő speciális üzembe helyezési körülményeket és biztonságos üzemelési távolságok alkalmazását.

## European Zone 2 Certification

This equipment is intended for use in potentially explosive atmospheres as defined by European Union Directive 94/9/EC. Underwriters Laboratory International DEMKO certifies that this equipment has been found to comply with the Essential Health and Safety Requirements relating to the design and construction of Category 3 equipment intended for use in potentially explosive

atmospheres, given in Annex II to this Directive. Compliance with the Essential Health and Safety Requirements has been assured by compliance with EN 50021 (1999).

## Installation Guidelines

When determining where to place the switch, observe these guidelines.

- Before installing the switch, first verify that the switch is operational by powering it on and running POST. Follow the procedures in the [“Powering On the Switch and Running POST”](#) section on page 3-14.
- For 10/100 ports and 10/100/1000 ports, the cable length from a switch to an attached device cannot exceed 328 feet (100 meters).
- For 100BASE-FX multimode fiber-optic (MM) ports, the cable length from a switch to an attached device cannot exceed 6562 feet (2 kilometers).
- For 100BASE-LX single-mode fiber-optic (SM) ports, the cable length from a switch to an attached device cannot exceed 9.375 miles (15 kilometers).
- Operating environment is within the ranges listed in [Appendix A, “Technical Specifications.”](#)
- Clearance to front and rear panels meet these conditions:
  - Front-panel LEDs can be easily read.
  - Access to ports is sufficient for unrestricted cabling.
  - Front-panel direct current (DC) power and relay connector is within reach of the connection to the DC circuit breaker.
- Airflow around the switch and through the vents is unrestricted. To prevent the switch from overheating, there must be a minimum of 3 inches between any other device and the top, bottom, or sides of the switch.
- Temperature surrounding the unit does not exceed 140°F (60°C).

**Note**

---

When the switch is installed in an industrial enclosure, the temperature within the enclosure is greater than normal room temperature outside the enclosure.

The temperature inside the enclosure cannot exceed 140°F (60°C), the maximum ambient enclosure temperature of the switch.

---

- Cabling is away from sources of electrical noise, such as radios, power lines, and fluorescent lighting fixtures.

## Verifying Package Contents

**Note**

---

Carefully remove the contents from the shipping container, and check each item for damage. If any item is missing or damaged, contact your Cisco representative or reseller for support. Return all packing materials to the shipping container and save them.

---

The switch is shipped with these items:

- *Catalyst 2955 Hardware Installation Guide* (Cisco part number DOC-7814944=)
- Power and relay connector
- One ring terminal lug (Cisco part number 27-1183-01)
- One single-block ferrite
- One RJ-45-to-DB-9 console port adapter cable

If you want to connect a terminal to the switch console port, you need to provide an RJ-45-to-DB-25 female DTE adapter. You can order a kit (part number ACS-DSBUASYN=) with that adapter from Cisco.

For multimode (MM) connections, you can connect a 100BASE-FX port to a port on a target device by using one of the MT-RJ fiber-optic patch cables listed in [Table B-1 on page B-5](#). Use the Cisco part numbers in [Table B-1](#) to order the patch cables that you need.

For single-mode (SM) connections, you can connect a 100BASE-LX port to a port on a target device by using one of the connectors listed in [Table B-2 on page B-6](#). Use the Cisco part numbers in [Table B-2](#) to order the patch cables that you need.

## Verifying Switch Operation



### Warning

---

If you connect or disconnect the console cable with power applied to the switch or any device on the network, an electrical arc can occur. This could cause an explosion in hazardous location installations. Be sure that power is removed or the area is nonhazardous before proceeding.

To verify switch operation, perform POST on the switch in a nonhazardous location before installation.

---

Before installing the switch on a DIN rail or in a 19-inch rack, you should power on the switch and verify that the switch passes power-on self-test (POST). These sections describe the steps required to connect a PC to the switch console port, to power on the switch, and to observe POST:

[Connecting a PC or a Terminal to the Console Port, page 3-12](#)

[Powering On the Switch and Running POST, page 3-14](#)

## Connecting a PC or a Terminal to the Console Port

To connect a PC to the console port, use the supplied RJ-45-to-DB-9 adapter cable. To connect a terminal to the console port, you need to provide an RJ-45-to-DB-25 female DTE adapter. You can order a kit (part number ACS-DSBUASYN=) with that adapter from Cisco. For console-port and adapter-pinout information, see the [“Cable and Adapter Specifications” section on page B-7](#).

The PC or terminal must support VT100 terminal emulation. The terminal-emulation software—frequently a PC application such as HyperTerminal or Procomm Plus—makes communication between the switch and your PC or terminal possible during the setup program.

Follow these steps to connect the PC or terminal to the switch:

- Step 1** Make sure that your terminal-emulation software is configured to communicate with the switch through hardware flow control.
- Step 2** Configure the baud rate and character format of the PC or terminal to match these console-port default characteristics:
- 9600 baud
  - Eight data bits
  - One stop bit
  - No parity

After gaining access to the switch, you can change the port baud rate. Refer to the switch software configuration guide for instructions.

- Step 3** Insert the adapter cable in the console port, as shown in [Figure 3-1](#). (See the “Cable and Adapter Pinouts” section on page B-10 for pinout descriptions.)

*Figure 3-1 Connecting to the Console Port*

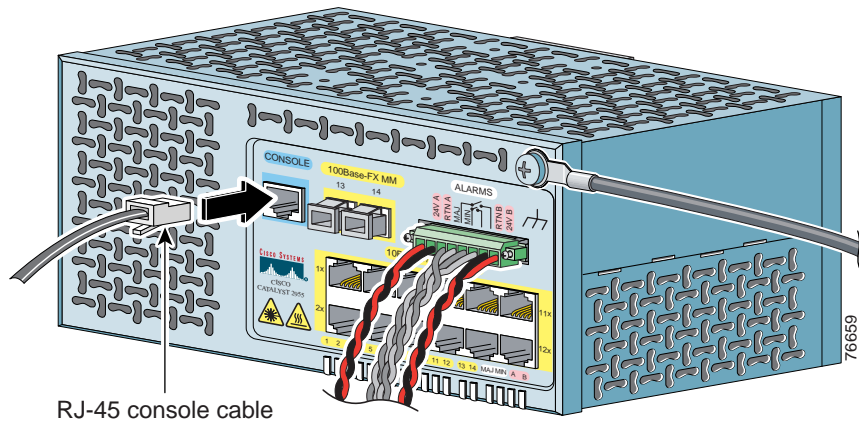

- Step 4** Attach the appropriate adapter to the terminal, if needed.
- Step 5** Insert the other adapter cable end in the PC or terminal adapter.
- Step 6** Start the terminal-emulation software.

## Powering On the Switch and Running POST



### Warning

---

If you connect or disconnect the console cable with power applied to the switch or any device on the network, an electrical arc can occur. This could cause an explosion in hazardous location installations. Be sure that power is removed or the area is nonhazardous before proceeding.

To verify switch operation, perform POST on the switch in a nonhazardous location before installation.

---



### Caution

---

The AC/DC power converter (PWR-2955-AC) can only be used in a nonhazardous location installation.

---

These sections describe the steps required to power on the switch and to observe POST:

[Grounding the Switch, page 3-15](#)

[Wiring the DC-Input Power Source, page 3-18](#)

[Add the Ferrite to the Power and Relay Connector Wiring, page 3-24](#)

[Attach the Power and Relay Connector to the Switch, page 3-25](#)

[Power On the Switch, page 3-26](#)

[Running POST, page 3-26](#)

Locate the power and relay connector, the ground screw, and the ring terminal lug in the switch kit.

Obtain these necessary tools and equipment:

- Ratcheting torque flathead screwdriver that exerts up to 15 inch pounds (in-lbs.) of pressure
- Panduit crimping tool with optional controlled cycle mechanism (model CT-700, CT-720, CT-920, CT-920CH, CT-930, or CT-940CH)
- 10- to 12-gauge copper ground wire (insulated or noninsulated)
- Four leads of 18-gauge copper wire
- Wire-stripping tools for stripping 10-to-12- and 18-gauge wires
- Single-block ferrite

## Grounding the Switch



**Warning**

---

This equipment is intended to be grounded to comply with emission and immunity requirements. Ensure that the switch functional ground lug is connected to earth ground during normal use.

---



**Warning**

---

When installing the unit, always make the ground connection first and disconnect it last.

---



**Warning**

---

Use twisted-pair supply wires suitable for 86°F (30°C) above surrounding ambient temperature outside the enclosure.

---



**Caution**

---

To make sure that the equipment is reliably connected to earth ground, follow the grounding procedure instructions, and use a UL-listed lug suitable for number 10-to-12 AWG wire and an M-5 thread ground screw.

---

To ground the switch to earth ground by using the functional ground screw, follow these steps. Make sure to follow any grounding requirements at your site.

- 
- Step 1** Locate the functional ground screw on the front panel of the switch and the ring terminal from the switch kit. Use a standard Phillips screwdriver or a ratcheting torque screwdriver with a Phillips head to remove the screw. Store the ground screw and the ring terminal for later use.
- Step 2** If your ground wire is insulated, use a wire stripping tool to strip the 10- to 12-gauge ground wire to 0.5 inch (12.7 millimeter [mm]) 0.02 inch (0.5 mm) as shown in [Figure 3-2](#).

**Figure 3-2** *Stripping the Ground Wire*

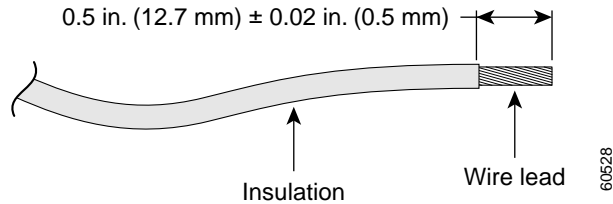

- Step 3** Slide the ground wire and the ring terminal around the ground screw.
- Step 4** Insert the ground screw into the functional ground screw opening on the front panel.



- Step 5** Using a Panduit crimping tool, crimp the ring terminal to the 10- to 12-gauge wire.

*Figure 3-3 Crimping the Ring Terminal*

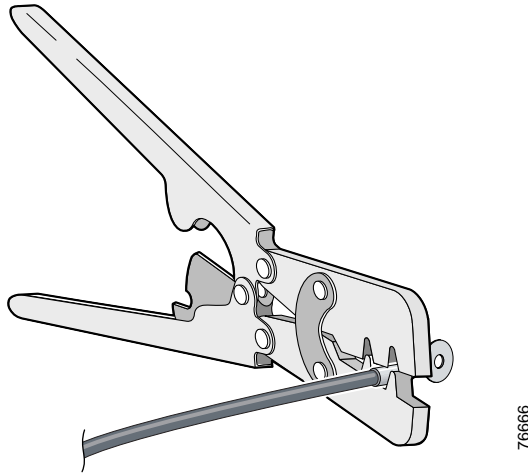

- Step 6** Using a ratcheting torque screwdriver, tighten the ground screw and ground wire to the switch front panel to 15 in-lbs. (240 ounce-force inches [ozf-in.]), as shown in [Figure 3-4](#).

Figure 3-4 Torquing Ground-Lug Screws

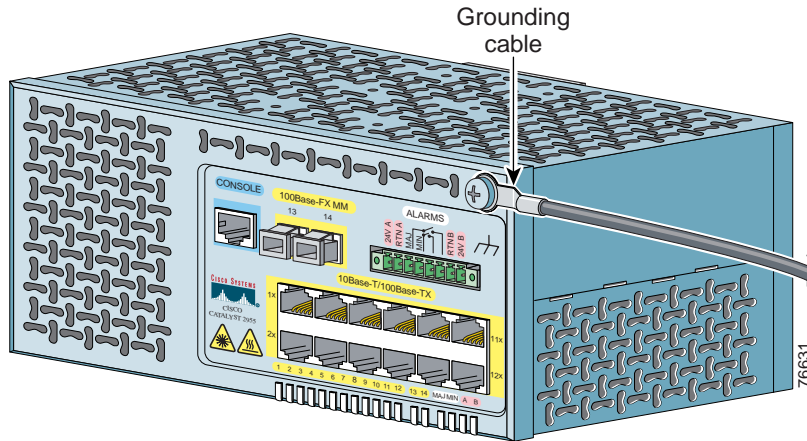

- Step 7** Attach the other end of the ground wire to a grounded bare metal surface, such as a ground bus, a grounded DIN rail, or a grounded bare rack.

## Wiring the DC-Input Power Source



**Warning**

Only trained and qualified personnel should be allowed to install or replace this equipment.



**Warning**

In switch installations in a hazardous location, the DC power source could be located away from the vicinity of the switch. Be sure that power is removed and power cannot be accidentally be turned on or the area is nonhazardous before proceeding.

**Warning**

When you disconnect the power and relay connector with power applied to the switch, an electrical arc can occur. This could cause an explosion in hazardous area installations. Be sure that power is removed from the switch and cannot be accidentally be turned on, or verify that the area is nonhazardous before proceeding.

Failure to securely tighten the power and relay connector captive screws can result in an electrical arc if the connector is accidentally removed.

**Warning**

Connect the unit only to DC power source that complies with the safety extra-low voltage (SELV) requirements in IEC 60950 based safety standards.

**Caution**

The AC/DC power converter (PWR-2955-AC) can only be used in a nonhazardous location installation.

**Caution**

You must connect the Catalyst 2955 switch only to a DC-input power source that has an input supply voltage from 18 to 30 VDC. If the supply voltage is not in this range, the switch might not operate properly or might be damaged.

**Caution**

The switch must be installed with 2 A-branch-circuit protection.

**Caution**

This installation must comply with all applicable codes.

To wire the switch to a DC-input power source, follow these steps:

- Step 1** Locate the power and relay connector (see [Figure 3-5](#)).

**Figure 3-5** Power and Relay Connector

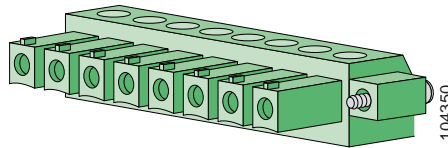

- Step 2** Identify the positive and negative feed positions for the power and relay connector. The positive DC power input for power supply A is labeled 24 V A, and the return for power supply A is labeled RTN A. For power supply B (the redundant power supply), the positive DC power input is labeled 24 V B, and the return is labeled RTN B.
- Step 3** Measure two strands of twisted-pair copper wire (18 to 20 AWG) long enough to connect to the DC power source.
- Step 4** Using an 18-gauge wire-stripping tool, strip each of the two wires coming from each DC-input power source to 0.25 inch (6.3 mm) ± 0.02 inch (0.5 mm). Do not strip more than 0.27 inch (6.8 mm) of insulation from the wire. Stripping more than the recommended amount of wire can leave exposed wire from the power and relay connector after installation.

**Figure 3-6** Stripping the DC-Input Power Source Wire

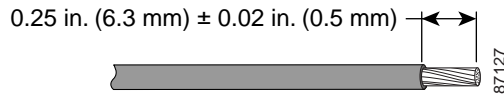

- Step 5** Insert the exposed wire of one of the four DC-input power source wires into the power and relay connector, as shown in [Figure 3-7](#). Make sure that you cannot see any wire lead. Only wire *with insulation* should extend from the connector.



**Warning**

An exposed wire lead from a DC-input power source can conduct harmful levels of electricity. Be sure that no exposed portion of the DC-input power source wire extends from the power and relay connector.

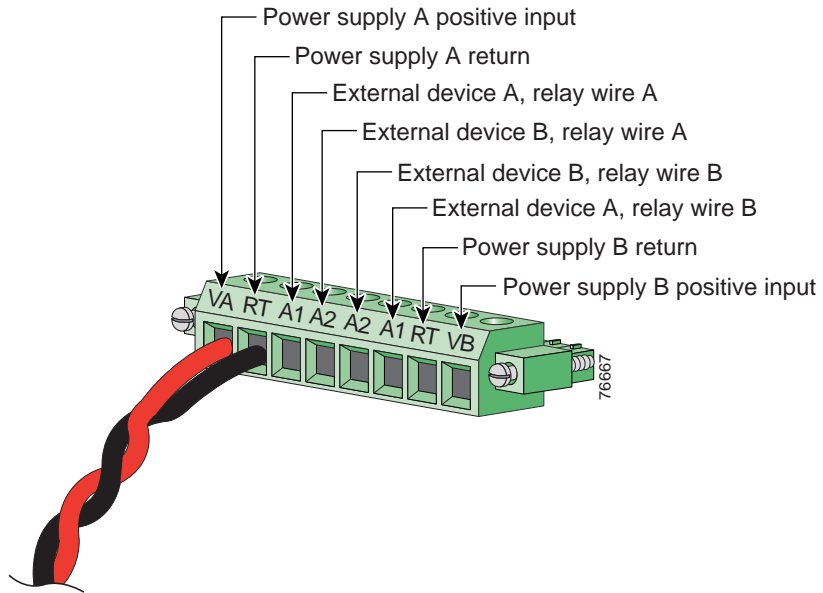
*Figure 3-7 Inserting Wires in the Power and Relay Connector*

- Step 6** Use a ratcheting torque flathead screwdriver to torque the power and relay connector captive screw (above the installed wire lead) to 4.5 in-lbs. (72 ozf-in.). (See [Figure 3-8](#).)

**Caution**

Do not overtorque the power and relay connector captive screws. The recommended maximum torque is 4.5 in-lbs.

*Figure 3-8 Torquing the Power and Relay Connector Captive Screws*

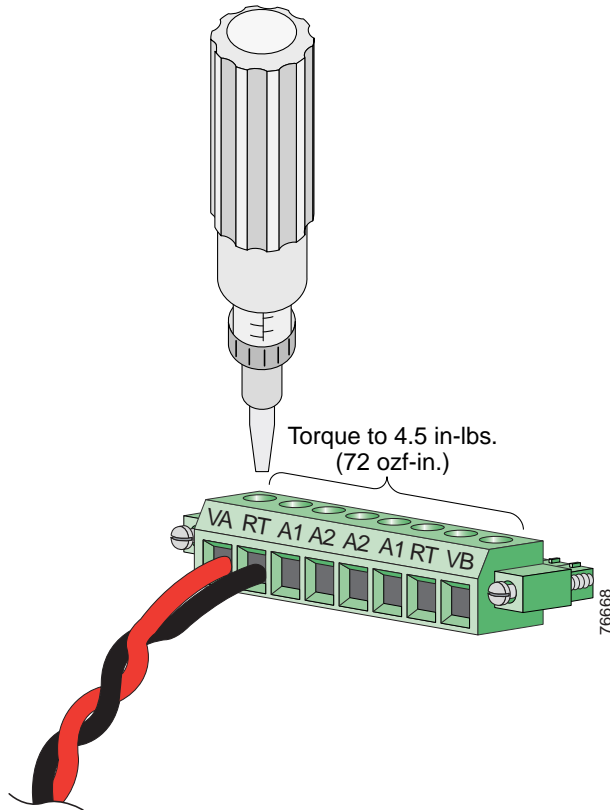

**Step 7** Repeat [Step 4](#) through [Step 6](#) for the return wire for the primary DC power source.



**Note** If you are connecting a second power supply, repeat [Step 4](#) through [Step 6](#) for the DC-input (24V B) and return (RTN B) for power supply B.

Figure 3-9 shows the completed DC-input wiring for two power supplies on a power and relay connector.

**Figure 3-9** Completed DC Power Connections on the Power and Relay Connector

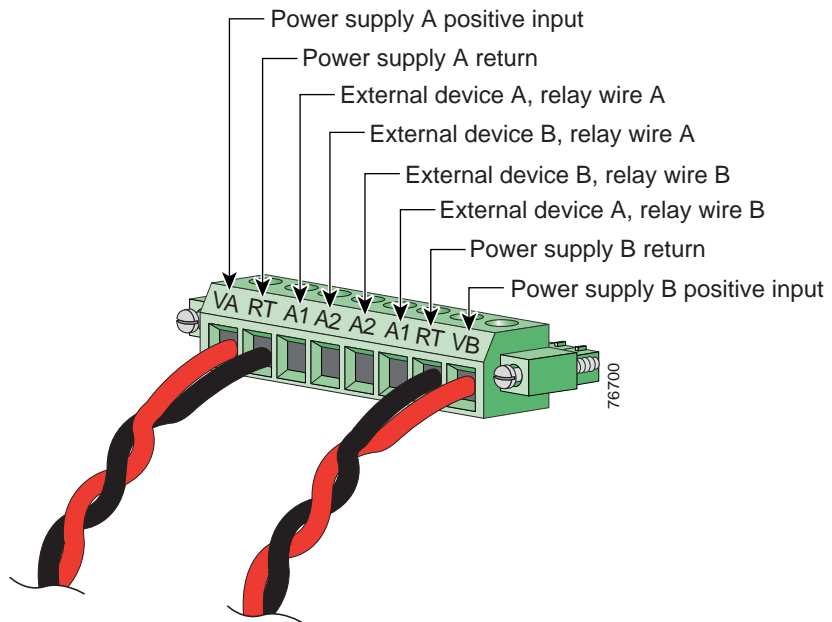

**Note** If you plan to connect external alarm devices to the alarm relays, proceed to the “[Wiring the External Alarm Device Relays](#)” section on page 3-28. Otherwise, proceed to the next step.

**Step 8** Proceed to the next section, “[Add the Ferrite to the Power and Relay Connector Wiring](#)” for instructions on how to attach the ferrite to the power and relay connector wiring.

## Add the Ferrite to the Power and Relay Connector Wiring

Before you connect the power and relay connector to the front panel, follow these steps to add a ferrite to the power and relay connector wiring.



### Note

If you plan to connect external alarm devices to the alarm relays, first proceed to the [“Wiring the External Alarm Device Relays”](#) section on page 3-28.

- Step 1** Grasp the power and relay connector wiring, and attach a ferrite close to the connector.
- Step 2** Loop the cable around the ferrite and back through the center to secure the ferrite. See [Figure 3-10](#) for details.

*Figure 3-10 Loop the Wiring Through the Ferrite*

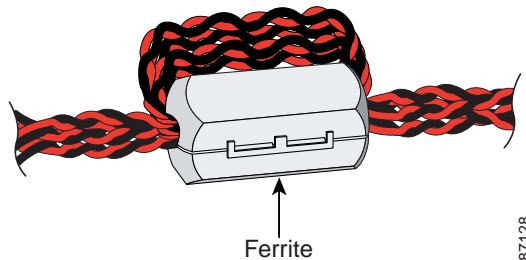

- Step 3** Proceed to the [“Attach the Power and Relay Connector to the Switch”](#) section on page 3-25 for instructions on how to attach the power and relay connector to the front panel of the switch.





## Power On the Switch

Locate the circuit breaker on the panel board that services the DC circuit, and switch the circuit breaker to the ON position.

## Running POST

After the power is connected, the switch automatically begins POST, a series of tests that verifies that the switch functions properly.



### Note

---

The uplink port status LEDs provide system and status information during POST. On the Catalyst 2955C-12 and Catalyst 2955S-12, the uplink ports are labeled 13 and 14. On the Catalyst 2955T-12, the uplink ports are labeled 1 and 2.

---



### Warning

---

**If you connect or disconnect the console cable with power applied to the switch or any device on the network, an electrical arc can occur. This could cause an explosion in hazardous location installations. Be sure that power is removed or the area is nonhazardous before proceeding.**

---

**To verify switch operation, perform POST on the switch in a nonhazardous location before installation.**

---

When the Catalyst 2955C-12 and Catalyst 2955S-12 begin POST:

- Uplink port 13 LED is amber.
- Uplink port 14 LED blinks green.

When the Catalyst 2955T-12 begins POST:

- Uplink port 1 LED is amber.
- Uplink port 2 LED blinks green.

If POST completes successfully on the Catalyst 2955C-12 and Catalyst 2955S-12:

- Uplink port 13 LED turns green.
- Uplink port 14 LED goes off during the FLASH file system initialization.

If POST completes successfully on the Catalyst 2955T-12:

- Uplink port 1 LED turns green.
- Uplink port 2 LED goes off during the FLASH file system initialization.

If POST fails on the Catalyst 2955C-12 and Catalyst 2955S-12:

- Uplink port 13 LED blinks amber.
- Uplink port 14 LED turns green.

If POST fails on the Catalyst 2955T-12:

- Uplink port 1 LED blinks amber.
- Uplink port 2 LED turns green.

If your switch fails POST, see [Chapter 4, “Troubleshooting,”](#) to determine a corrective action.

**Note**

---

Call Cisco Systems immediately if your switch does not pass POST.

---

While the switch powers on, the power status LEDs are green. During POST, the power status LEDs are off. After POST completes successfully, the power status LEDs turn green if both power supplies are functioning normally and the switch has been configured to operate in dual power mode.

If the switch is configured to operate in single power mode operation, only the primary power status LED is on. If the primary power supply is not functioning normally or is not present, the power status LED turns amber. Refer to the switch configuration guide for details on single and dual power mode operation.

On a Catalyst 2950 switch, you can use the MODE button to recover the switch password. The Catalyst 2955 switch has no MODE button, so the boot loader compensates by using break key detection to stop the automatic boot sequence for password recovery.

On the Catalyst 2955C-12 and Catalyst 2955S-12 switches, during the initial appearance of the boot loader prompt on the console after POST, uplink port 13 LED blinks green, and uplink port 14 LED is off. On the Catalyst 2955T-12 switch, during the initial appearance of the boot loader prompt on the console after POST, uplink port 1 LED blinks green, and uplink port 2 LED is off.

**Note**

---

Refer to the switch software configuration guide for details on the Catalyst 2955 switch password recovery process.

---

After successfully running POST, follow these steps.

- 
- Step 1 Turn off power to the switch.
  - Step 2 Disconnect the cables.
  - Step 3 Decide where you want to install the switch.
- 

## Wiring the External Alarm Device Relays

The alarm relays on the Catalyst 2955 switch are normally open (NO). To connect an external alarm device to the relays, you must connect two relay contact wires to complete an electrical circuit. Because each external alarm device requires two connections to a relay, the Catalyst 2955 switch supports a maximum of two external alarm devices.



### Warning

The switch relays are rated at 1 Amp and have a voltage limit of 30 VDC and 0.3 Amp at a voltage limit of 125 VAC. It is dangerous to exceed these limitations in a hazardous environment.

**An electrical arc can occur when you connect or disconnect the relay wires with field side power applied. This could cause an explosion in switch installations in a hazardous location. Before proceeding, be sure that power is removed or the area is not hazardous.**

After you have completed the wiring for the DC power connections, follow these steps to wire the switch to an external alarm device:



### Note

This procedure is optional.

- 
- Step 1 Measure one strand of twisted-pair wire (18 to 20 AWG) long enough to connect to the external alarm device.
  - Step 2 Use a wire stripper to remove the casing from both ends of the wire to 0.25 inch (6.3 mm) 0.02 inch (0.5 mm). Do not strip more than 0.27 inch (6.8 mm) of insulation from the wire. Stripping more than the recommended amount of wire can leave exposed wire from the power and relay connector after installation.

- Step 3** Insert the exposed wire for the external alarm device (alarm relay wire A) into the wire entry hole for the alarm relay contact, as shown in [Figure 3-12](#).

*Figure 3-12 Inserting Relay Wires into the Power and Relay Connector*

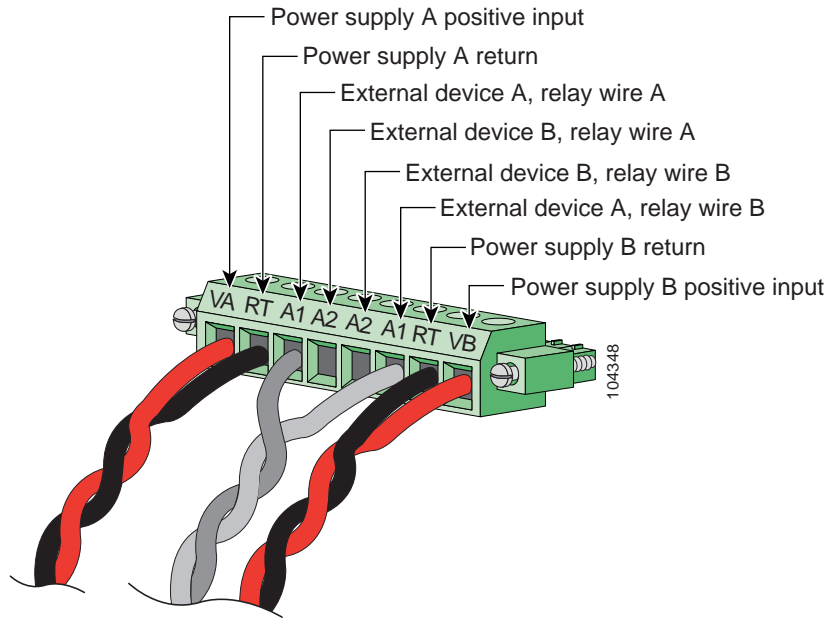

- Step 4** Use a ratcheting torque flathead screwdriver to torque the power and relay connector captive screw (above the installed wire lead) to 4.5 in-lbs. (72 ozf-in.). (See [Figure 3-13](#) for details.)



**Caution**

Do not overtorque the power and relay connector captive screws. The recommended maximum torque is 4.5 in-lbs.

*Figure 3-13 Torquing the Power and Relay Connector Captive Screws*

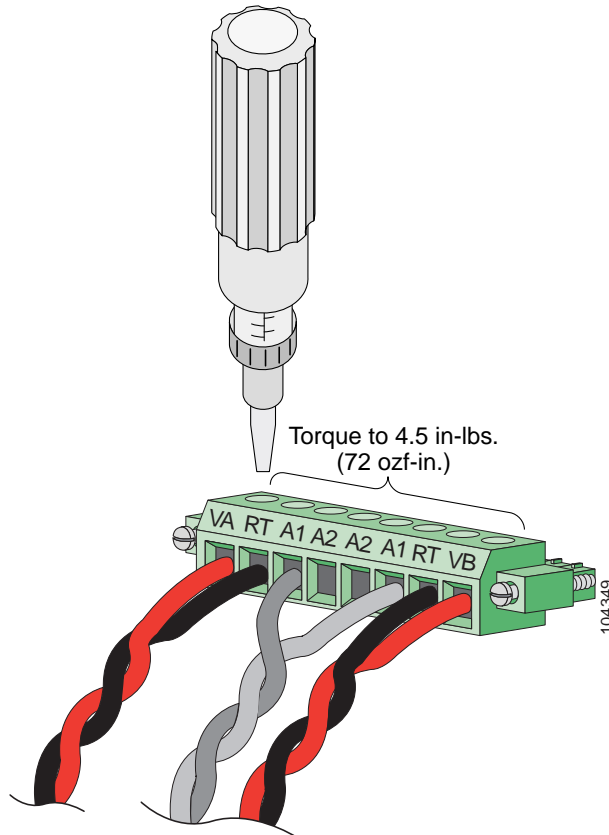

Step 5 Repeat [Step 1](#) through [Step 4](#) to connect alarm relay wire B.



**Note**

To connect an additional external alarm device to the alarm relays, repeat [Step 1](#) through [Step 4](#) for the relay input and output wires.

Figure 3-14 shows the completed wiring for two external alarm devices on a power and relay connector.

*Figure 3-14 Completed Connections for Two External Alarm Devices on the Power and Relay Connector*

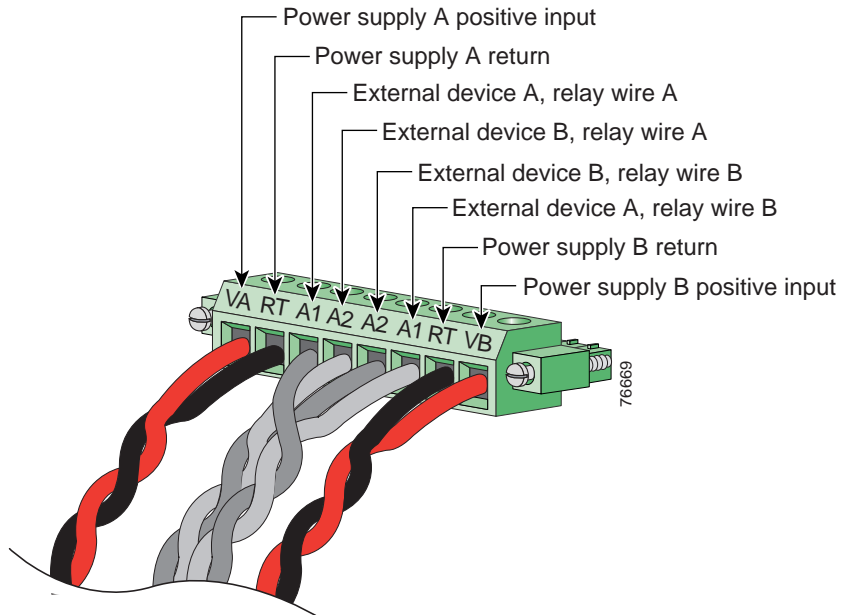

**Note**

---

See the “[Add the Ferrite to the Power and Relay Connector Wiring](#)” section on [page 3-24](#) for instructions on how to attach the ferrite to the power and relay connector wiring.

See the “[Attach the Power and Relay Connector to the Switch](#)” section on [page 3-25](#) for instructions on how to connect the power and relay connector to the front panel.

---

## Installing the Switch on a DIN Rail

You can mount the Catalyst 2955 switch on a DIN rail in a parallel or a face-down configuration.

**Warning**

---

This equipment is supplied as “open type” equipment. It must be mounted within an enclosure that is suitably designed for those specific environmental conditions that will be present and appropriately designed to prevent personal injury resulting from accessibility to live parts. The interior of the enclosure must be accessible only by the use of a tool.

The enclosure must meet IP 54 or NEMA type 4 minimum enclosure rating standards.

---

**Warning**

---

When used in a Class I, Division 2, hazardous location, this equipment must be mounted in a suitable enclosure with proper wiring method, for all power, input and output wiring, that complies with the governing electrical codes and in accordance with the authority having jurisdiction over Class I, Division 2 installations.

---

**Caution**

---

To prevent the switch from overheating, there must be a minimum of 3 inches between any other device and the top, bottom, or sides of the switch.

---



**Note**

---

The Catalyst 2955 switch ships with the clip assembly installed on the rear panel of the switch for a parallel mounting configuration.

To mount the switch in a face-down configuration, use a screwdriver to remove the clip assembly from the rear panel and then install it on the top of the switch.

---

To attach the switch to a DIN rail, follow the procedures in this section.

**Step 1**

---

Position the rear panel of the switch directly in front of the DIN rail, making sure that the DIN rail meets the mounting clip assembly, as shown in [Figure 3-15](#) and [Figure 3-19](#).

*Figure 3-15 Mounting the Switch on a DIN Rail in a Parallel Configuration*

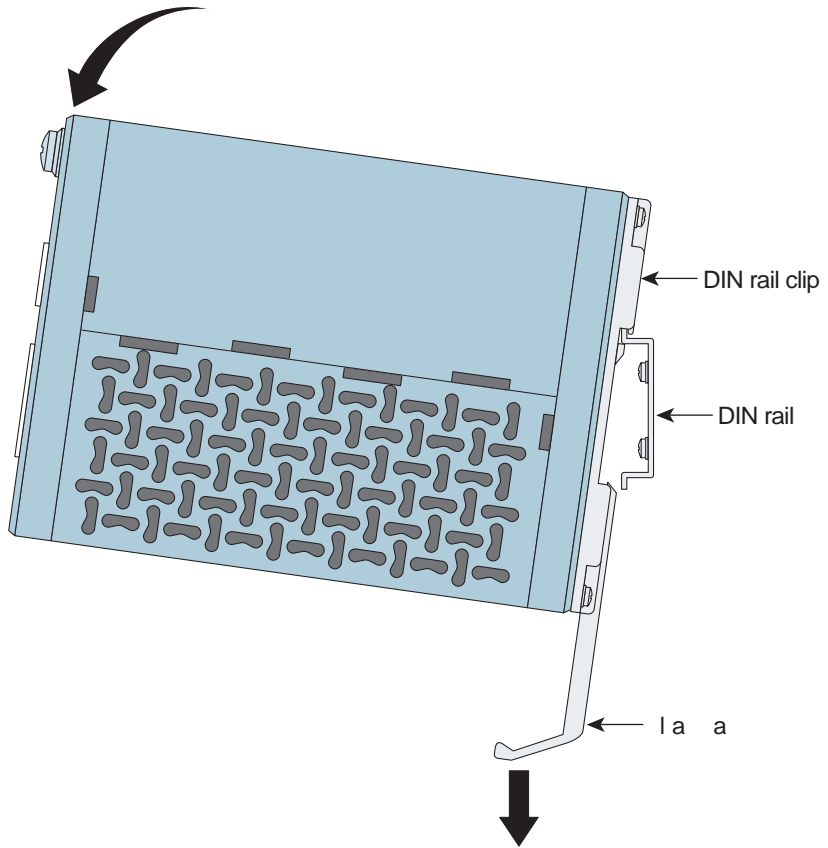

*Figure 3-16 Mounting the Switch on a DIN Rail in a Face-Down Configuration*

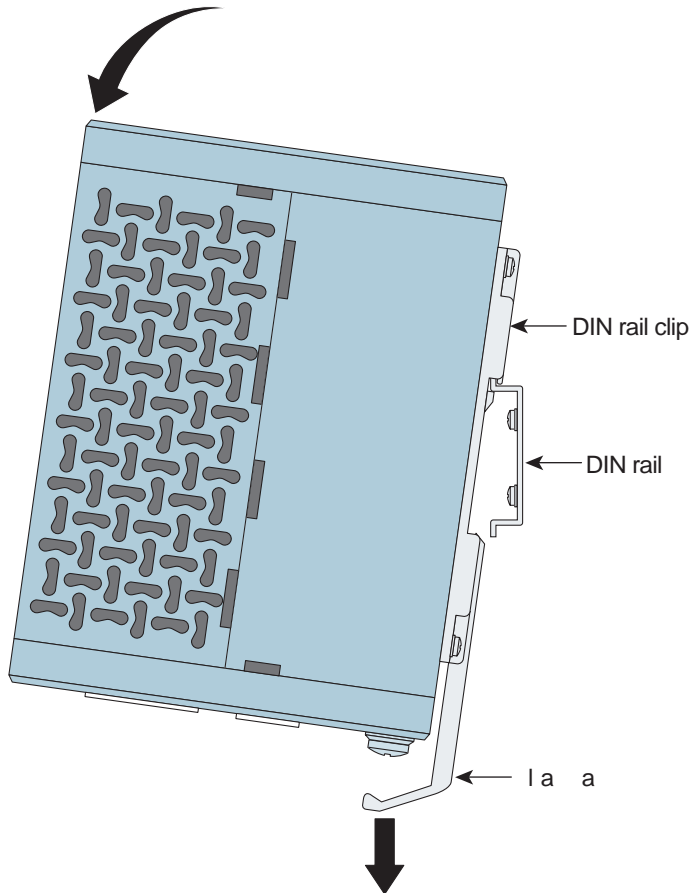

- Step 2** Pull down on the clip release tab as you press the switch toward the DIN rail.
- Step 3** When the switch makes contact with the top and bottom of the DIN rail, let go of the clip release tab.
- Step 4** Push down lightly on the switch to ensure that it is firmly locked in place.

---

After the switch is mounted on the DIN rail, power on the switch as described in [“Powering On the Switch and Running POST”](#) section on page 3-14.

**Note**

---

For instructions on how to remove the switch from a DIN rail, see the [“Removing the Switch from a DIN Rail or a Rack”](#) section on page 3-39.

---

## Installing the Switch in a Rack

**Warning**

---

To prevent bodily injury when mounting or servicing this unit in a rack, you must take special precautions to ensure that the system remains stable. The following guidelines are provided to ensure your safety:

- This unit should be mounted at the bottom of the rack if it is the only unit in the rack.
  - When mounting this unit in a partially filled rack, load the rack from the bottom to the top with the heaviest component at the bottom of the rack.
  - If the rack is provided with stabilizing devices, install the stabilizers before mounting or servicing the unit in the rack.
- 

**Caution**

---

To prevent the switch from overheating, there must be a minimum of 3 inches between any other device and the top, bottom, or sides of the switch.

---

You can use an optional DIN rail adapter kit (available through Cisco, part number STK-RACKMNT-2955=) to mount the Catalyst 2955 switch in a 19-inch rack. The rack mounting kit comes with a DIN rail adapter and screws to attach the adapter to the rack. Ask your Cisco representative for details.

To install the switch in a rack, follow these steps:

- Step 1** Use the four Phillips machine screws to securely attach the brackets to the rack, as shown in [Figure 3-17](#).

*Figure 3-17 Installing the DIN Rail Adapter*

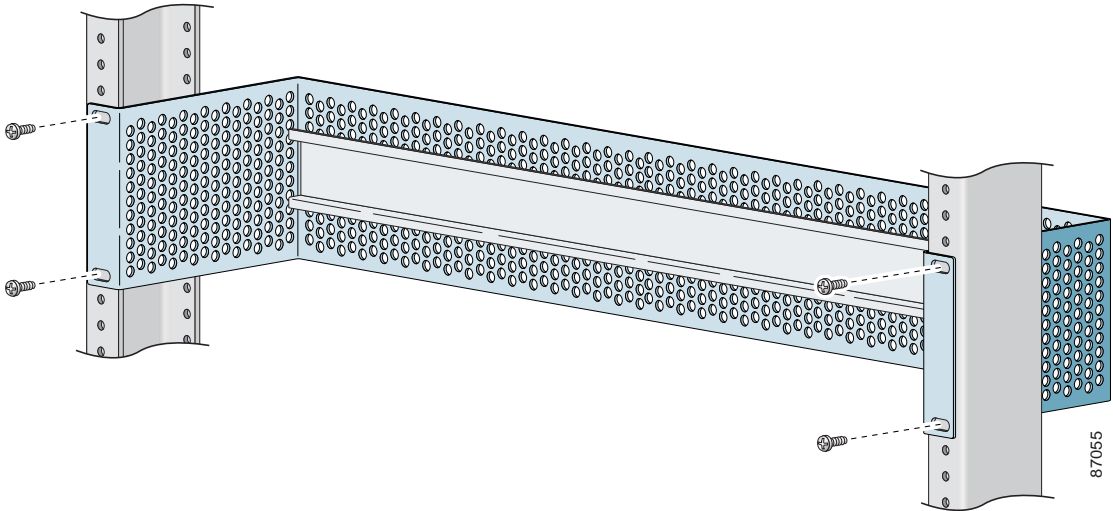

- Step 1** Position the rear panel of the switch directly in front of the DIN rail, making sure that the DIN rail meets the mounting clip assembly, as shown in [Figure 3-15](#) and [Figure 3-16](#).
- Step 2** Pull down on the clip release tab as you press the switch toward the DIN rail.
- Step 3** When the switch makes contact with the top and bottom of the DIN rail, let go of the clip release tab. See [Figure 3-15](#) for details.
- Step 4** Push down lightly on the switch to ensure that it is firmly locked in place. See [Figure 3-18](#) for details.

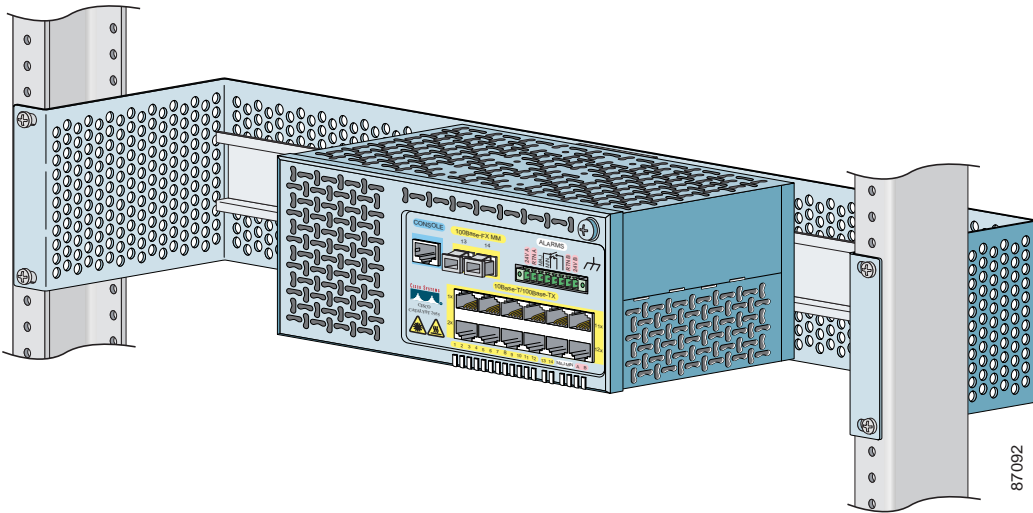
*Figure 3-18 Installing the Switch in a Rack*

After mounting the switch in the rack, start the terminal-emulation software, and provide power to the switch. See the [“Powering On the Switch and Running POST”](#) section on page 3-14 for instructions.

**Note**

For instructions on how to remove the switch from a rack, see the [“Removing the Switch from a DIN Rail or a Rack”](#) section on page 3-39.

# Removing the Switch from a DIN Rail or a Rack

To remove the switch from a DIN rail or a rack, follow these steps:

---

**Step 1** Ensure that power is removed from the switch (if applicable), and disconnect all cables and connectors from the switch front panel.

**Step 2** Detach the switch from the DIN rail or rack:



---

**Note** The DIN rail clip release tab might not be easily accessible in some mounting configurations. If you cannot reach the tab, insert a long flathead screwdriver into the tab slot and pull down to release the clip.

---

- For a parallel mounting configuration, pull down on the clip release tab on the rear of the switch as you lift the switch front panel, as shown in [Figure 3-19](#).

■ Removing the Switch from a DIN Rail or a Rack

*Figure 3-19 Removing the Switch in a Parallel Configuration from a DIN Rail or a Rack*

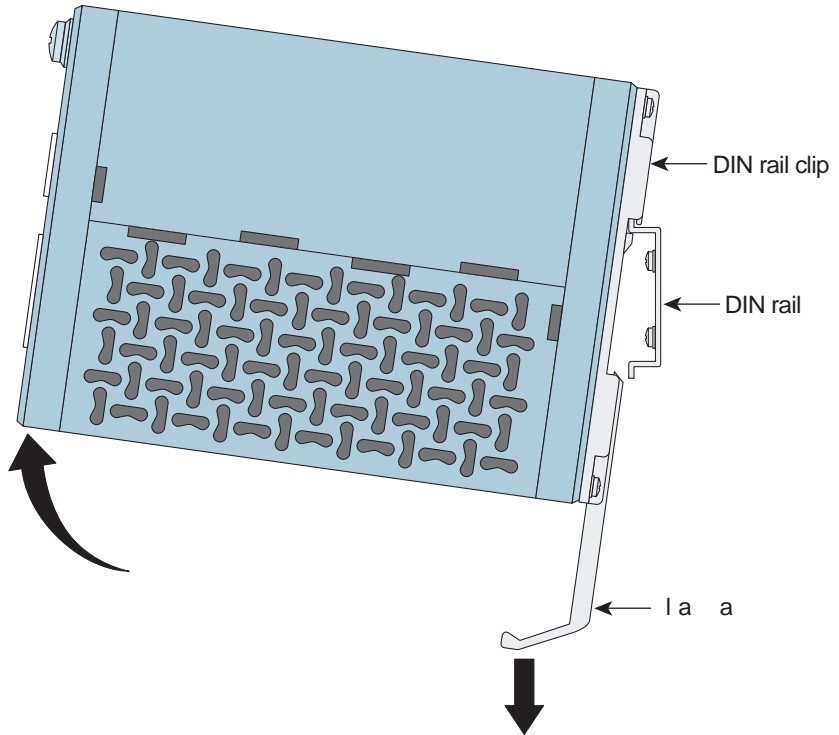



- For a face-down mounting configuration, pull down on the release tab on the top panel of the switch as you lift the switch front panel, as shown in [Figure 3-20](#).

**Figure 3-20** *Removing the Switch in a Face-Down Configuration from a DIN Rail or a Rack*

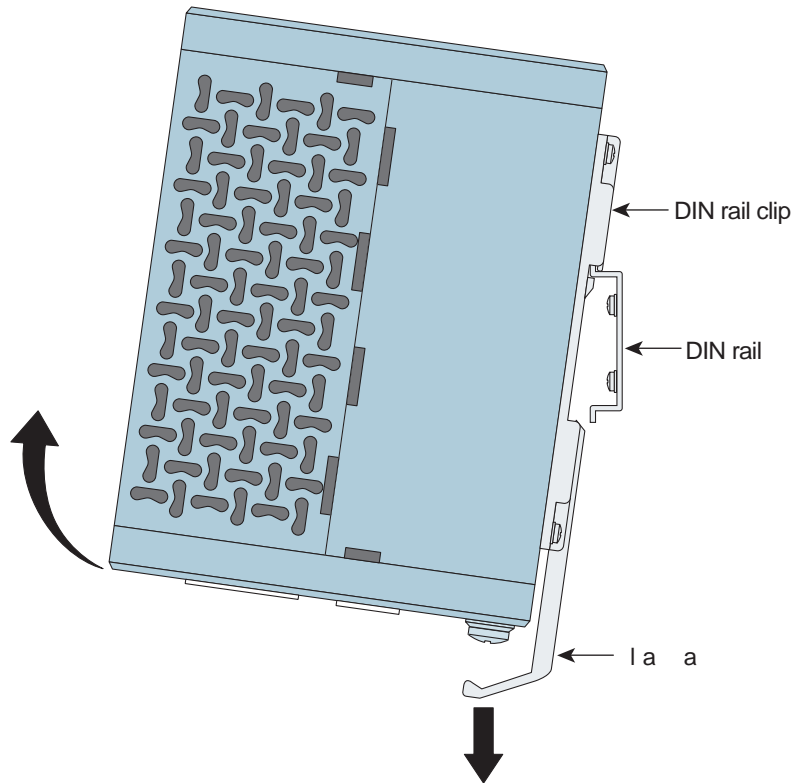

## Connecting to 10/100 and 10/100/1000 Ports

The 10/100 ports on the Catalyst 2955 configure themselves to operate at the speed and duplex settings of attached devices. They operate at 10 or 100 Mbps in half- or full-duplex mode. If the attached devices do not support autonegotiation, you can explicitly set the speed and duplex parameters.

The 10/100/1000 ports configure themselves to operate at the speed setting of attached devices. These ports on the Catalyst 2955T-12 operate at either 10 or 100 Mbps in either full- or half-duplex mode or at 1000 Mbps in full-duplex mode. If the attached devices do not support autonegotiation, you can explicitly set the speed parameter.

Connecting devices that do not autonegotiate or devices with manually set speed and duplex parameters can reduce performance or result in link failures between the devices. To maximize performance, choose one of these methods for configuring the ports:

- Let the ports autonegotiate both speed and duplex for 10/100 ports and speed for 10/100/1000 ports.
- Set the speed and duplex parameters on both ends of the connection.



### Warning

---

**Do not connect or disconnect cables to the ports while power is applied to the switch or any device on the network because an electrical arc can occur. This could cause an explosion in hazardous location installations. Be sure that power is removed from the switch and cannot be accidentally be turned on, or verify that the area is nonhazardous before proceeding.**

---



### Caution

---

Proper ESD protection is required whenever you handle Cisco equipment. Installation and maintenance personnel should be properly grounded using ground straps to eliminate the risk of ESD damage to the switch.

Do not touch connectors or pins on component boards. Do not touch circuit components inside the switch. When not in use, store the equipment in appropriate static-safe packaging.

---

Follow these steps to connect the switch to 10BASE-T, 100BASE-TX, or 1000BASE-T devices:

- Step 1** When connecting to servers, workstations, and routers, insert a twisted-pair straight-through cable in a front-panel RJ-45 connector, as shown in [Figure 3-21](#) and [Figure 3-22](#). When connecting to switches or repeaters, insert a twisted-pair crossover cable. (See the “[Cable and Adapter Specifications](#)” section on page B-7 for cable-pinout descriptions.)



- Note** When connecting to 1000BASE-T devices, be sure to use a four twisted-pair, Category 5 cable.

*Figure 3-21 Connecting to a 10/100 Port on the Catalyst 2955 Switch*

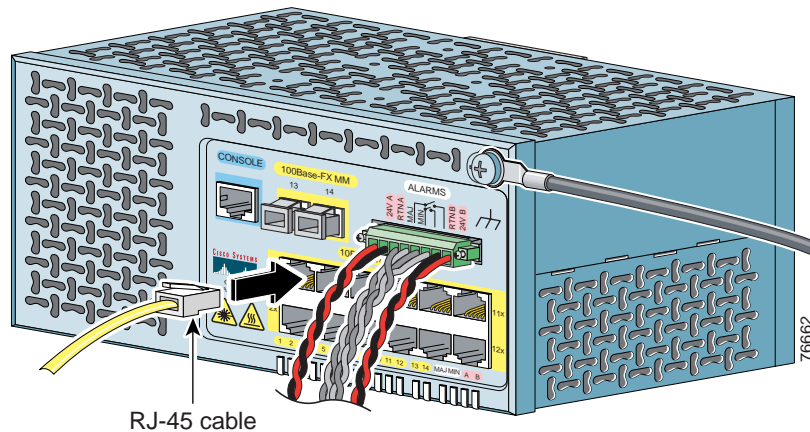

*Figure 3-22 Connecting to a 10/100/1000 Port on the Catalyst 2955T-12 Switch*

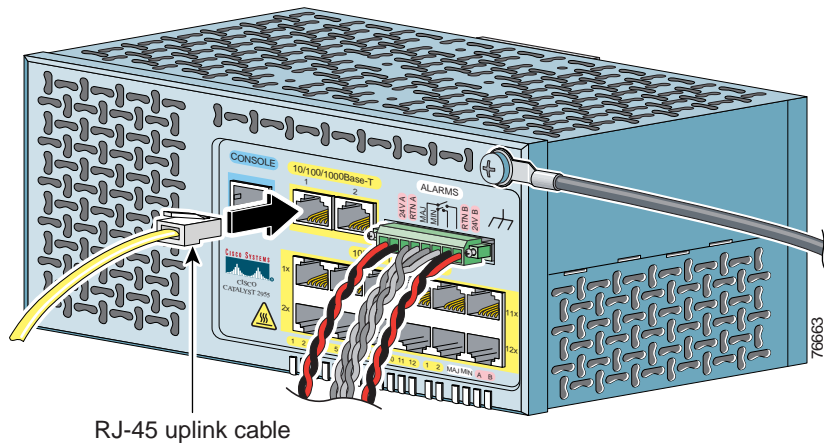

- RJ-45 uplink cable
- Step 2** Insert the other cable end in an RJ-45 connector on the target device.
- Step 3** Observe the port status LED.
- The LED turns green when the switch and the target device have an established link.
- The LED turns amber while Spanning Tree Protocol (STP) discovers the network topology and searches for loops. This process takes about 30 seconds, and then the LED turns green.
- If the LED is off, the target device might not be turned on, there might be a cable problem, or there might be a problem with the adapter installed in the target device. See [Chapter 4, “Troubleshooting,”](#) for solutions to cabling problems.
- Step 4** Reconfigure and restart the target device if necessary.
- Step 5** Repeat Steps 1 through 4 to connect each port.

## Connecting to 100BASE-FX MM Ports

The 100BASE-FX MM fiber-optic uplink ports operate in full-duplex mode.

You can connect a 100BASE-FX port to a port on a target device by using one of the MT-RJ fiber-optic patch cables listed in [Table B-1 on page B-5](#). Use the Cisco part numbers in [Table B-1](#) to order the patch cables that you need.



Warning

---

**Do not connect or disconnect cables to the ports while power is applied to the switch or any device on the network because an electrical arc can occur. This could cause an explosion in hazardous location installations. Be sure that power is removed from the switch and cannot be accidentally be turned on, or verify that the area is nonhazardous before proceeding.**

---



Warning

---

**LED radiation is present when the system is open.**

---



Warning

---

**Class 1 LED product**

---



Caution

---

**Do not remove the dust plugs from the fiber-optic ports or the rubber caps from the fiber-optic cable until you are ready to connect the cable. The plugs and caps protect the fiber-optic ports and cables from contamination and ambient light.**

---

Follow these steps to connect the switch to a MM 100BASE-FX device:

- Step 1** Remove the dust plugs from the 100BASE-FX port, as shown in [Figure 3-23](#), and store them for future use. Remove the rubber caps from the MT-RJ patch cable. Store them for future use.

*Figure 3-23 Removing Dust Plugs from 100BASE-FX Ports*

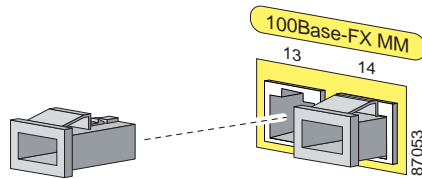

- Step 2** Insert the cable in a 100BASE-FX port. (See [Figure 3-24](#).)

*Figure 3-24 Connecting to a 100BASE-FX MM Port*

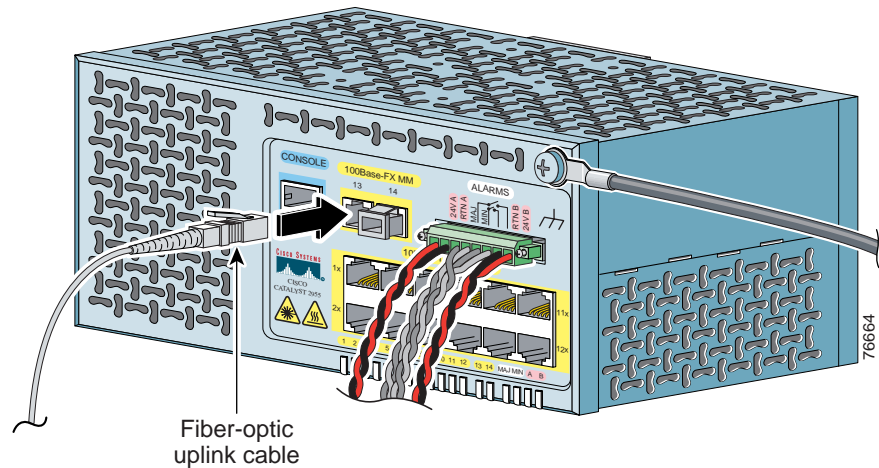

- Step 3** Insert the other cable end in an SC or ST port on the target device.
- Step 4** Observe the port status LED.
- The LED turns green when the switch and the target device have an established link.
- The LED turns amber while STP discovers the network topology and searches for loops. This process takes about 30 seconds, and then the port LED turns green.
- If the LED is off, the target device might not be turned on, there might be a cable problem, or there might be a problem with the adapter installed in the target device. See [Chapter 4, “Troubleshooting,”](#) for solutions to cabling problems.
- Step 5** Reconfigure and restart the target device, if necessary.
- Step 6** Repeat Steps 1 through 5 to connect each port.
- 

## Connecting to 100BASE-LX SM Ports

You can connect a 100BASE-LX port to a port on a target device by using one of the LC fiber-optic patch cables listed in [Table B-2 on page B-6](#). Use the Cisco part numbers in [Table B-2](#) to order the patch cables that you need.

Follow these steps to connect the switch to a 100BASE-LX SM device:



Warning

---

Do not connect or disconnect cables to the ports while power is applied to the switch or any device on the network because an electrical arc can occur. This could cause an explosion in hazardous location installations. Be sure that power is removed from the switch and cannot be accidentally be turned on, or verify that the area is nonhazardous before proceeding.

---



Warning

---

Laser radiation is present when the system is open.

---



Warning

---

Invisible laser radiation may be emitted from disconnected fibers or connectors. Do not stare into beams or view directly with optical instruments.

---

**Warning****Avoid exposure to the laser beam.****Caution**

Do not remove the dust plugs from the fiber-optic ports or the rubber caps from the fiber-optic cable until you are ready to connect the cable. The plugs and caps protect the fiber-optic ports and cables from contamination and ambient light.

- Step 1** Remove the dust plugs from the 100BASE-LX port, as shown in [Figure 3-25](#), and store them for future use. Remove the rubber caps from the LC on the fiber-optic cable. Store them for future use.

*Figure 3-25 Removing Dust Plugs from 100BASE-LX Ports*

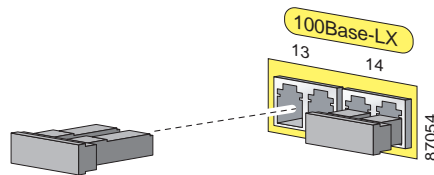

- Step 2** Insert the cable in a 100BASE-LX port. (See [Figure 3-26](#).)

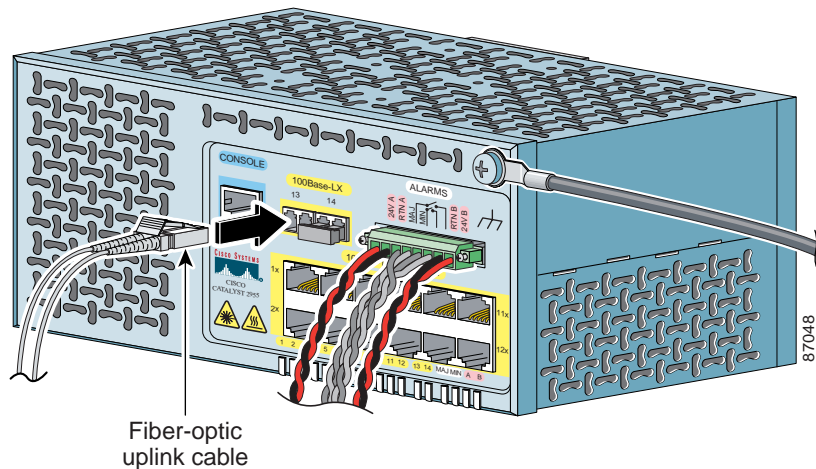

*Figure 3-26 Connecting to a 100BASE-LX SM Port*

**Step 3** Insert the other cable end in an LC port on the target device.

**Step 4** Observe the port status LED.

The LED turns green when the switch and the target device have an established link.

The LED turns amber while STP discovers the network topology and searches for loops. This process takes about 30 seconds, and then the port LED turns green.

If the LED is off, the target device might not be turned on, there might be a cable problem, or there might be a problem with the adapter installed in the target device. See [Chapter 4, “Troubleshooting,”](#) for solutions to cabling problems.

**Step 5** Reconfigure and restart the target device, if necessary.

**Step 6** Repeat Steps 1 through 5 to connect each port.

## Where to Go Next

For information about starting the switch, refer to the release notes for the Catalyst 2955 switch.

For information about configuring the switch, refer to the switch software configuration guide.