

Introduction

Designed for use with the EtherSwitch 1420 Ethernet switch, the EtherSwitch 1420 modules consist of three Fiber Distributed Data Interface (FDDI) modules that support both fiber-optic and Category 5 unshielded twisted pair (UTP) cabling and four 100BaseT modules that support the 100BaseTX and 100BaseFX physical media specifications.

Without interrupting the network, these hot-swappable modules plug directly into the EtherSwitch 1420 high-speed expansion slots. The EtherSwitch 1420 then automatically configures the module to the network and verifies its operation.

CiscoPro product documentation and additional literature are available on a CD called Cisco Connection Documentation, CiscoPro Solutions. The CD is updated and shipped monthly, so it might be more current than printed documentation. To order the Cisco Connection Documentation, CiscoPro Solutions CD in North America, contact your local reseller; international customers, contact your local Cisco sales office. The CD is available both as a single CD and as an annual subscription. You can also access CiscoPro product documentation on the World Wide Web URL <http://www.cisco.com>.

Key Features

- Data rates of up to 200 Mbps in full-duplex mode.
- Field-installable and hot-swappable.
- Available in UTP or fiber-optic media interface.
- Fully manageable with any SNMP management station or with the EtherSwitch 1420 management console. The FDDI modules are manageable via any SMT management station.
- Automatic packet recognition and translation for IPX networks for FDDI modules.

Packing List

- IP fragmentation support for FDDI modules.
- Bridge tunneling support in AppleTalk networks for FDDI modules.

Packing List

Before going any further, make sure that the following items have been included with this package. If anything is missing, contact your Cisco customer service representative.

- EtherSwitch 1420 modules
- This *EtherSwitch 1420 Modules Installation Guide*
- Warranty package

FDDI Modules

All network connectors and LEDs are on the FDDI module front panels. These panels are shown in Figure 1-1 and described in the following sections.

FDDI Fiber DAS Module

The FDDI Fiber DAS module is a dual-attach station (DAS) compatible with the ANSI X3T12 standard. It has two MIC connectors and uses 50/125- or 62.5/125-micron multimode fiber-optic cabling. It also has a 6-pin mini-DIN connector to connect to an optical bypass switch.

FDDI Fiber SAS Module

The FDDI Fiber SAS module is a single-attach station (SAS) compatible with the ANSI X3T12 standard. It has one MIC connector and uses 50/125- or 62.5/125-micron multimode fiber-optic cabling.

Figure 1-1 FDDI Modules

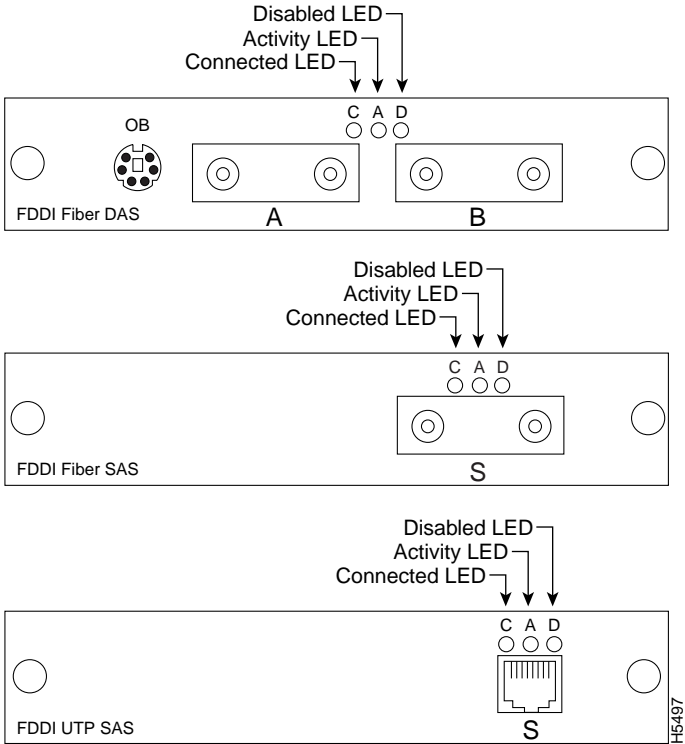

FDDI UTP SAS Module

The FDDI UTP SAS module is a single-attach station (SAS) compatible with the ANSI X3T12 standard. It has an RJ-45 connector and uses two-pair Category 5 UTP cabling.

FDDI Module LEDs

The following LEDs on the front panel indicate a module's operating status:

- **Connected**

This LED is on when the module is connected to an operational FDDI ring. It is off when the device is not connected to the FDDI ring.

- **Activity**

This LED blinks when the corresponding port is transmitting or receiving data. It blinks rapidly when the traffic level is high; it is off when there is no activity.

- **Disabled**

This LED is on when the port has been disabled by administrative intervention or by a secure address violation. You can disable a port with the EtherSwitch 1420 management console.

The LEDs also indicate the type of failure when the module does not pass the power-on self-test (POST). See Table 2-1 in the "Installation" chapter for more information.

100BaseT Modules

The four 100BaseT modules support the 100BaseTX or 100BaseFX physical layer specifications. All network connectors and LEDs are located on the module front panel, as shown in Figure 1-2.

100BaseT Ports

The 100BaseT modules are available in 100BaseTX and 100BaseFX configurations, supporting both switched and shared 100-Mbps operation.

The single-switched 100BaseT ports provide a dedicated 100 Mbps of bandwidth for direct connection to a single server, workstation, or another EtherSwitch 1420. The shared 100BaseT ports connect to the same types of devices as the switched 100BaseT ports but share 100 Mbps of bandwidth across all the ports.

100BaseTX Modules

The 100BaseTX modules are compatible with the 100BaseT IEEE 802.3u standard. They have RJ-45 connectors and use two-pair Category 5 UTP cabling. The following port configurations are available:

- One switched 100BaseTX port
- Eight shared 100BaseTX ports

100BaseFX Modules

The 100BaseFX modules are compatible with the 100BaseT IEEE 802.3u standard. They have ST connectors and use 50/125- or 62.5/125-micron multimode fiber-optic cabling. The following port configurations are available:

- One switched 100BaseFX port
- Four shared 100BaseFX ports

100BaseT Modules

Figure 1-2 100BaseT Modules

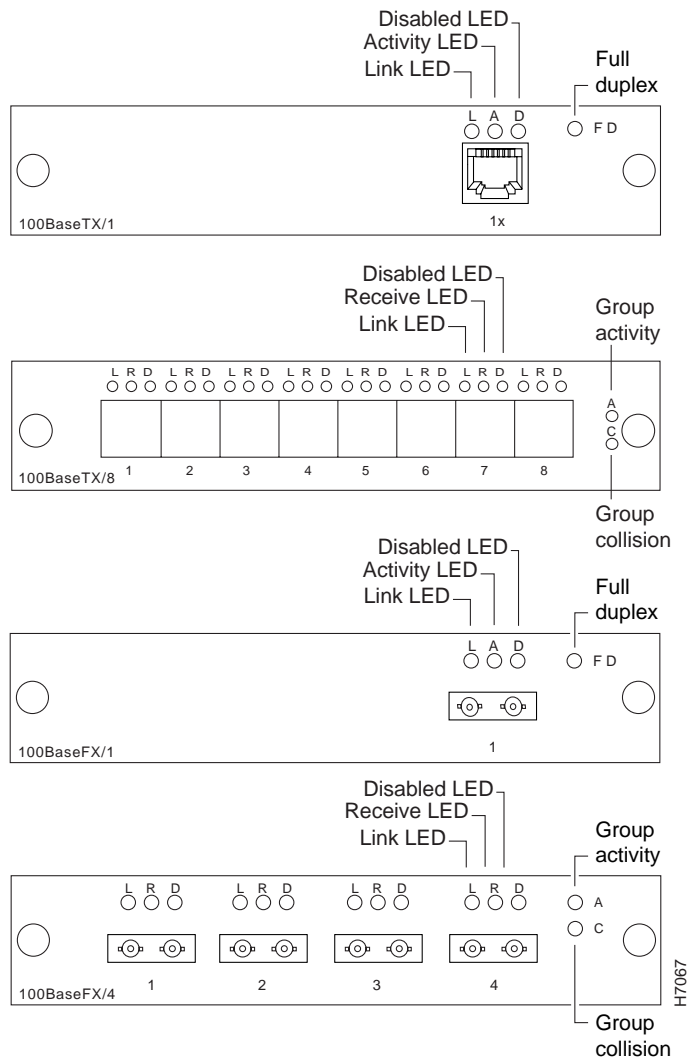

100BaseT Module LEDs

All of the 100BaseT modules have individual port LEDs. The shared 100BaseT modules have two group-status LEDs, and the switched 100BaseT modules have a full-duplex LED. The LEDs, shown in Figure 1-2, are described in the following list:

- **Port Status LEDs**

Three status LEDs are provided for each individual 100BaseT port: link integrity, network activity, receive (shared 100BaseT ports only), and disabled.

- **Link**

The link LED indicates that the 100BaseT port is properly connected to a powered-up device. This LED is on when the link-integrity test passes and off when the link integrity test fails.

- **Activity (Switched 100BaseT Ports Only)**

The activity LED for switched 100BaseT ports blinks when the corresponding port is transmitting or receiving data. If the traffic level is high, this LED is on continuously. This LED is off when there is no activity.

- **Receive (Shared 100BaseT Ports Only)**

The receive LED for shared 100BaseT ports blinks whenever the corresponding port is receiving data. If the traffic level is high, this LED is on continuously. This LED is off when there is no activity.

- **Disabled**

The disabled LED is on when the 100BaseT port is disabled or suspended, either by a network connection error or secure address violation, or manually disabled or suspended using the EtherSwitch 1420 management console. If a shared 100BaseT port is automatically disabled due to a jabber or autopartition error, this LED blinks.

- **Full-Duplex LED (Switched 100BaseT Modules Only)**

The full-duplex LED is on when the switched 100BaseT port is operating in full-duplex mode and off when the port is operating in half-duplex mode.

100BaseT Modules

- **Group Status LEDs**

The shared 100BaseT modules have two group-status LEDs:

- **Group activity**

The group activity LED blinks when the corresponding shared 100BaseT ports are transmitting or receiving data. If the traffic level is high, this LED is on continuously. This LED is off when there is no activity.

- **Group collision**

The group collision LED blinks when the corresponding shared 100BaseT ports detect a packet collision. This LED is off when no packet collisions are detected.