

Reading LED Indicators

This appendix provides a summary of all the LEDs (status indicators) used in the router. The LED on the interface processor end of the router and on the RP indicate the system power and processor status; LEDs on the rest of the interface processors indicate the status of the individual interface processor and its interfaces.

DC OK LED

The DC OK LED, on the interface processor end of the AC-input and DC-input power supplies, goes on when the power supply is receiving AC or DC source power and providing DC power to the internal system components. The power supply monitors its own temperature and internal voltages. For a description of the power supply shutdown conditions and threshold status levels, refer to the section “Environmental Monitoring and Reporting Functions” in the chapter “Product Overview.”

Figure B-1 DC OK LED—AC-Input Power Supply Shown

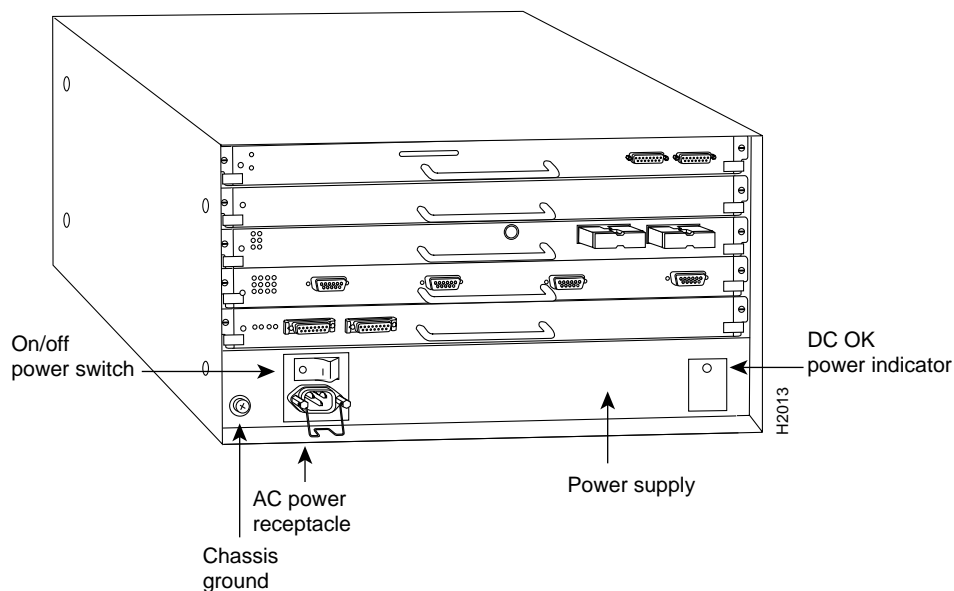

SP and SSP LEDs

The SP and SSP have an enabled LED. The enabled LED goes on to indicate that the SP or SSP is operational and powered up. All enabled LEDs (on the SP, SSP, and interface processors) go on when the boot sequence is complete. If the enabled LEDs do not come on, one of the following errors is indicated:

- The SP or SSP or interface processor is not installed correctly (not fully seated in the backplane connector).
- The microcode and software that are loading at startup are not compatible.
- The SP or SSP or interface processor has failed.

RP LEDs

The three LEDs on the RP, which are shown in Figure B-2, indicate the system and RP status. The normal LED goes on to indicate that the system is operational. During normal operation, the CPU halt and boot error LEDs on the RP should be off. When the system is turned on or restarted, the boot error LED goes on for one or two seconds, then goes off. The CPU halt LED, which goes on only if the system detects a processor hardware failure, should stay off. If the boot error LED stays on for more than 5 seconds, the system is unable to boot and should be restarted. A successful boot is indicated when the boot error LED goes out; however, this does not necessarily mean that the system has reached normal operation.

Figure B-2 RP LEDs

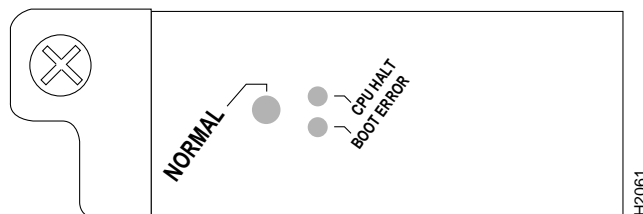

RSP7000 LEDs

Figure B-3 shows the LEDs on the RSP7000 faceplate. The LEDs on the RSP7000 indicate the system and RSP7000 status and which Flash memory card slot is active. The CPU halt LED, which goes on only if the system detects a processor hardware failure, should remain off. A successful boot is indicated when the normal LED goes on; however, this does not necessarily mean that the system has reached normal operation. During normal operation, the CPU halt LED should be off, and the normal LED should be on. The slot 0 and slot 1 LEDs indicate which PCMCIA (Flash memory) card slot is in use, and each LED blinks when the card is accessed by the system.



Caution The reset switch resets the RSP7000 and the entire system. To prevent system errors and problems, use it *only* at the direction of your service representative.

Figure B-3 RSP7000 LEDs

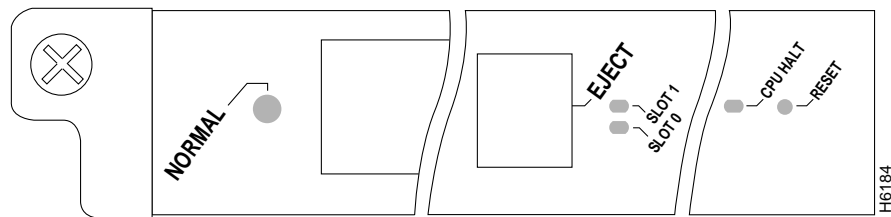

Interface Processor LEDs

Each interface processor (except the RP, which is not really an interface processor) contains an enabled LED. When on, this LED indicates that the interface processor is operational and that it is powered up. It does not necessarily mean that the interface ports are functional or enabled. The following sections describe the LEDs for each interface processor. The SP has no LEDs other than the enabled LED to indicate that it is operational.

AIP LEDs

The three LEDs above the ATM port (see Figure B-4) indicate the following:

- Enabled—When on, indicates that the AIP is enabled for operation; however, the interface ports might not be functional or enabled.
- RX cells —When on, indicates that the AIP has received an ATM cell. This LED will flicker in normal operation, indicating traffic.
- RX carrier —When on, indicates that the AIP has detected carrier on the RX cable. For a fiber-optic interface, this means simply that light is detected.

Figure B-4 AIP LEDs

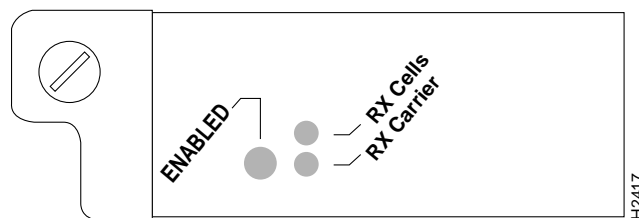

CIP LEDs

Following are the functions of the CIP LEDs. (See Figure B-5.)

- Enabled—Indicates that the CIP has been enabled for operation by the system.
- Present—Indicates that the adapter (ECA or PCA) has been detected by the CIP.
- Loaded—Indicates that the adapter (ECA or PCA) firmware has been completely loaded.
- Signal—For the ECA, this LED indicates that the Sync signal has been detected.

For the PCA, this LED indicates that the Operational Out signal has been detected. Note that even though a system reset and selective reset both cause the Operational Out signal to drop, the signal LED will still be on during those sequences.

- Online—For the ECA, this LED indicates that an establish-logical-path request has been received from the channel.
For the PCA, this LED indicates that the PCA is ready to establish connection to the host channel.

Figure B-5 CIP LEDs

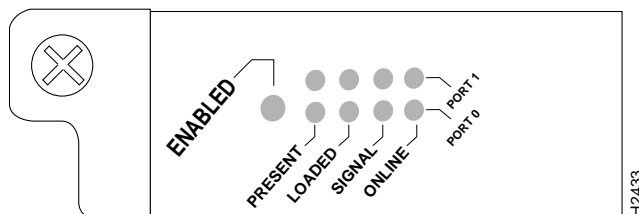

Following are the sequences for the CIP LED indicators. The enabled LED is not part of the following sequences. On cold boots, the following four LED sequences apply:

	Present	Loaded	Signal	Online
Port 1	On	On	Off	Off
Port 0	Off	Off	Off	Off

	Present	Loaded	Signal	Online
Port 1	On	On	On	On
Port 0	On	On	Off	Off

	Present	Loaded	Signal	Online
Port 1	On	On	On	On
Port 0	On	On	On	On

The following sequence indicates that the CIP is waiting for commands from the RP.

	Present	Loaded	Signal	Online
Port 1	Off	Off	Off	Off
Port 0	Off	Off	Off	Off

On warm boots, the LEDs flash briefly. On downloads, the following three LED sequences apply; the first indicates that the system is downloading volatile programmable logic device (VPLD) code:

	Present	Loaded	Signal	Online
Port 1	On	On	On	On
Port 0	On	On	On	Off

The following sequence indicates that the CIP is downloading microcode:

	Present	Loaded	Signal	Online
Port 1	Off	Off	Off	Off
Port 0	On	On	On	On

The following sequence indicates that the CIP is starting to execute the microcode:

	Present	Loaded	Signal	Online
Port 1	Off	Off	Off	Off
Port 0	Off	Off	Off	Off

EIP LEDs

The EIP contains a bank of 18 LEDs: one horizontal row of three LEDs for each of the six Ethernet interfaces, as shown in Figure B-6.

As with the other interface processors, the enabled LED goes on when the EIP is enabled for operation. Three LEDs for each port indicate the following:

- Collision—A frame collision has been detected.
- Transmit—Frames are being transmitted.
- Receive—Frames are being received.

Figure B-6 EIP LEDs

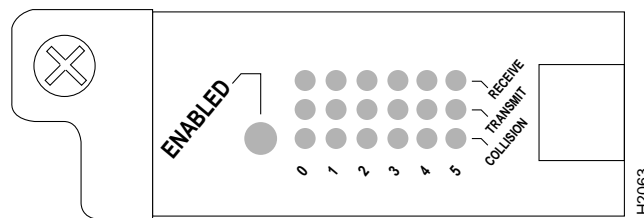

FEIP LEDs

The FEIP contains the enabled LED, standard on all interface processors, and a bank of three status LEDs for the ports. After system initialization, the enabled LED goes on to indicate that the FEIP has been enabled for operation. (The LEDs are shown in Figure B-7.) The following conditions must be met before the enabled LED goes on:

- The FEIP is correctly connected to the backplane and receiving power.
- The FEIP contains a valid microcode version that has successfully been downloaded.
- The bus recognizes the FEIP.

If any of these conditions is not met, or if the initialization fails for other reasons, the enabled LED does not go on.

Figure B-7 FEIP LEDs

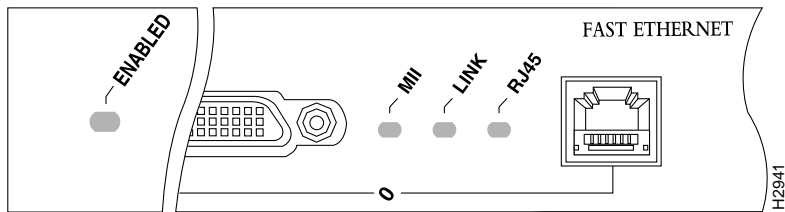

A bank of three LEDs indicates the following:

- MII—Lights when the MII port is selected as the active port by the controller.
- Link—Lights when the FEIP is receiving a carrier signal from the network.
- RJ-45—Lights when the RJ45 port is selected as the active port by the controller.

Either the MII LED *or* the RJ-45 LED should be on at one time; never both.

TRIP LEDs

The TRIP LEDs are shown in Figure B-8. Each horizontal row of three LEDs, one for each Token Ring interface, indicates the speed (4 or 16 Mbps) of the interface and whether the interface is inserted into the ring.

Figure B-8 TRIP LEDs

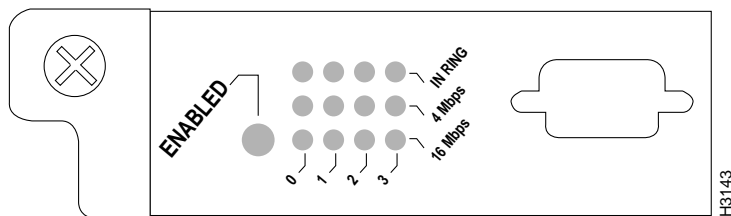

All TRIP interface processors, regardless of whether they provide two or four ports, contain the bank of LEDs shown in Figure B-8. As with the other interface processors, the enabled LED goes on when the TRIP is enabled for operation. Three LEDs for each port indicate the following:

- 16 Mbps—On when the interface is operating at 16 Mbps.
- 4 Mbps—On when the interface is operating at 4 Mbps.
- In Ring—When on, indicates that the interface is currently active and inserted into the ring. When off, indicates that the interface is not active and is not inserted into a ring.

FIP LEDs

The FIP LEDs are shown in Figure B-9. The LEDs on the left indicate the state of PHY B, and those on the right indicate the state of PHY A. (The PHY B interface is also to the left of the PHY A interface on the face of the FIP.) As with the other interface processors, the enabled LED goes on when the FIP is enabled for operation.

The state of each B/A pair of LEDs indicates the status of one type of three possible station connections: dual attachment station (DAS), single attachment station (SAS), or dual homed. The states of the FIP LED combinations, and the meanings of each are described and illustrated in Table B-1.

Figure B-9 FIP LEDs

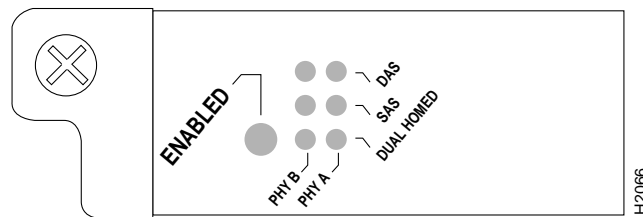

Table B-1 FIP LED States—Refer to Figure B-9

LED Pattern ¹	State	Indication
B A	DAS	Both LEDs off means <i>not connected</i> .
- -	Both LEDs off	Not connected
X X		
X X		
O O	Both LEDs on	Through A
X X		
X X		
O -	B on and A off	Wrap B
X X		
X X		
- O	B off and A on	Wrap A
X X		
X X		
B A	SAS	
X X		
- -	Both LEDs off	Not connected
X X		Single attachment B (PHY A shut down)
O -	B on and A off	
X X		
X X		Single attachment A (PHY B shut down)
- O	B off and A on	
X X		
B A	Dual Homed	

LED Pattern ¹	State	Indication
X X		Not connected
X X		
- -	Both B and A off	
X X		Dual homed with A active; not a normal condition; indicates potential problem on B
X O	Single attachment A on	
O O	plus both B and A on	
X X		Dual homed with B active, which is a normal condition
O X	Single attachment B on	
O O	plus both B and A on plus	
X X		Single attachment B, Dual homed A failed
O X	Single attachment B on	
O X	plus B on	
X X		Single attachment A, Dual homed B failed
X O	Single attachment A on	
X O	plus A on	

1. For the LED patterns, “-” means off, “O” means on, and “X” means does not apply.

FSIP LEDs

The FSIP LEDs are shown in Figure B-10. As with the other interface processors, the enabled LED goes on when the FSIP is enabled for operation. However, unlike the LED cluster on other interface processors, the LEDs for each serial port are adjacent to the connector. Table B-2 lists descriptions of each LED.

Figure B-10 FSIP LEDs

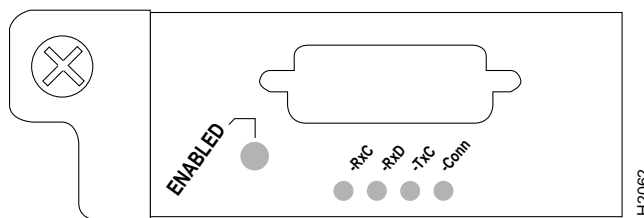

The conn (connected) LED goes on when the interface is connected to the network. During normal operation, the three other LEDs go on to indicate data and timing signal traffic, or an idle pattern that is commonly sent across the line during idle time.

Table B-2 FSIP LEDs

LED	DTE Signal	DCE Signal
RxC	Receive clock (from DTE)	(TxC) Transmit clock (to DTE)
RxD	Receive data (from DTE)	(TxD) Transmit data (from DTE)
TxC	Send timing (from DCE)	(RxC) Receive timing (to DTE)

LED	DTE Signal	DCE Signal
Conn	Connected	Connected

The labels on each LED indicate the signal state when the FSIP port is in DTE mode. However, the direction of the signals is reversed when the FSIP port is in DCE mode. For example, a DCE device usually generates a clock signal, which it sends to the DTE device.

Therefore, when the Receive Clock (RxC) LED goes on, on a DTE interface, it indicates that the DTE is receiving the clock signal from the DCE device. However, when the RxC LED goes on, on a DCE interface, it indicates that the DCE is sending a clock signal (RxC) to the DTE device. Because of limited space on the FSIP faceplate, only DTE mode states are labeled on each port.

Figure B-11 shows the signal flow between a DTE and DCE device and the LEDs that correspond to signals for each mode. The following LED state descriptions include the meanings for both DTE and DCE interfaces.

- **RxC**— On DTE interfaces, this LED is on when the port is receiving a transmit clock signal (TxC) from the remote DCE device, which is usually a DSU or modem.
On DCE interfaces, this LED indicates TxC (Transmit Clock). This LED is on when the DCE port is sending a transmit clock (TxC) signal to the remote DTE device.
- **RxD (Receive Data)**—On DTE interfaces, this LED is on when the port is receiving data signals (packets) from the network through the remote DCE device. This LED is also on when it detects an idle pattern that is commonly sent across the network during idle time.
On DCE interfaces, this LED indicates TxD (transmit data). During normal DCE operation, this LED is on when the DCE port is receiving data packets from the network through the remote DTE device.
- **TxC (Transmit Clock)**—On DTE interfaces, this LED is on when the port is receiving the transmit clock signal from the remote DCE.
On DCE interfaces, this LED indicates receive clock (RxC). During normal DCE operation, this LED is on when the DCE port is *sending* the internal clock signal (which the FSIP generates) to the remote DTE device, which is usually a host, PC, or another router.
- **Conn (connected or loopback)**—On both DTE and DCE interfaces, this LED is on to indicate normal operation: the FSIP is properly connected to the external device, and TA (DTE available) and CA (DCE available) are active. When this LED is off, the FSIP is in loopback mode or is not connected to the network or external device. (See Table B-2.)

Figure B-11 DTE to DCE Signals

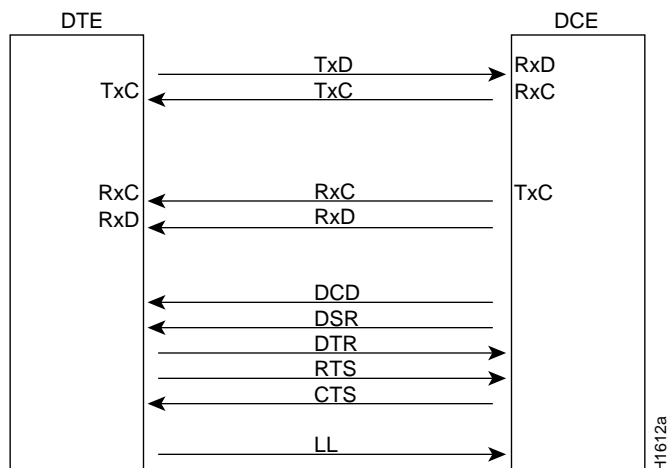

The default mode for all interface ports *without a port adapter cable attached* is DCE, although there is no default clockrate set on the interfaces. The DCE default allows you to perform local loopbacks without having to terminate the port or connect a cable. Because the serial adapter cables determine the mode and interface type, the FSIP port becomes a DTE when a DTE cable is connected to it. If a DTE cable is connected to a port with a clockrate set, the DTE will ignore the clockrate and use the external clock signal that is sent from the remote DCE.

HIP LEDs

Four LEDs on the HIP indicate different states of the HSSI interface. As with the other interface processors, the enabled LED goes on when the HIP is enabled for operation. The four LEDs above the HSSI port (see Figure B-12) indicate the following.

Figure B-12 HIP LEDs

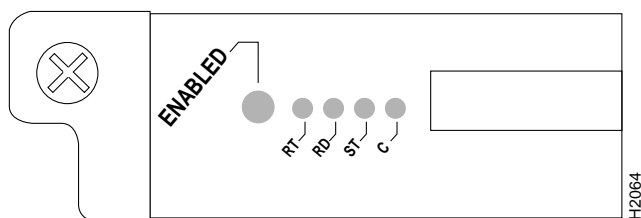

- RT (Receive Timing)—When on, indicates that the HIP has detected a Receive Clock signal. During normal operation, this signal is received from the external DSU. During loopback, this signal is generated internally.
- RD (Receive Data)—When on, indicates that the HIP has detected and is able to receive packets from the external DSU.
- ST (Send Timing)—When on, indicates that the HIP is transmitting a Transmit Clock signal to the external DSU. During normal operation, this signal is derived from the Receive Timing (RT) signal from the external DSU. During loopback, this signal is generated internally.
- C (connected)—When on, indicates normal operation; the HIP is properly connected to the external DSU, and TA (DTE available) and CA (DCE available) are active. When off, indicates that the HIP is in loopback mode or is not connected to the DSU.

MIP LEDs

After system initialization, the enabled LED (shown in Figure B-13), which is present on all interface processors, turns on to indicate that the MIP has been enabled for operation.

Figure B-13 MIP LEDs

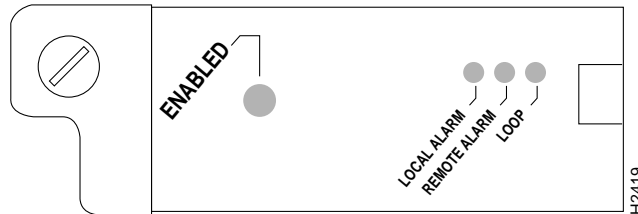

The following conditions must be met before the MIP is enabled:

- The MIP contains a valid microcode version that has successfully been downloaded.
- The MIP is correctly connected to the backplane and receiving power.
- The CxBus recognizes the MIP card.

If any of these conditions is not met, or if the initialization fails for other reasons, the enabled LED does not turn on.

There are three LEDs associated with each MIP port that indicate alarm or loop conditions on that port. The three LEDs above each MIP port indicate the following:

- Local alarm—Indicates a loss of signal, a loss of frame, or unavailability due to excessive errors.
- Remote alarm—Indicates a remote alarm is received from the remote end due to a local alarm at the remote end.
- Loop—Indicates controller local loopback.

