



Customer Order Number: DOC-781385=
Documentation Part Number: 78-1385-04

FSIP and SSIP, E1-G.703/G.704 Port Adapter Interface Installation and Configuration

Product Numbers: PA-7KF-E1/120, PA-7KF-E1/120=, PA-7KF-E1/75, and PA-7KF-E1/75=

This document provides descriptions, installation instructions, and configuration guidelines for the Fast Serial Interface Processor (FSIP) and Standard Serial Interface processor (SSIP) E1-G.703/G.704 port adapter interface. The E1-G.703/G.704 interface supports both framed (G.704) and unframed (G.703) modes of operation; the default is unframed operation.

The E1-G.703/G.704 interface is a 2.048 megabit per second (Mbps), E1 telecommunications interface; all the other available FSIP interfaces are synchronous serial data communications interfaces.

Many of the FSIP and SSIP features and functions are common to both types of interfaces; this document describes the E1-G.703/G.704 features that differ from those for the data communications interfaces. Use this document as a supplement to the information in the configuration note *Fast Serial Interface Processor (FSIP) Installation and Configuration* (Document Number 78-1047-03, or later, or *Standard Serial Interface Processor (SSIP) Installation and Configuration* (Document Number 78-2245-01, or later). Refer to the FSIP or SSIP configuration notes as your primary source of information, and refer to this supplement for specific E1-G.703/G.704 information where the cross-references appear. Use of the E1-G.703/G.704 port adapter in the Standard Serial Interface Processor (SSIP) is identical to that in the FSIP.

The information in this supplement includes an overview of G.703, instructions for installing and connecting an FSIP with E1-G.703/G.704 interfaces, and descriptions of the E1-G.703/G.704 interface configuration subcommands. For complete descriptions of the interface subcommands and the configuration options available for serial interfaces, refer to the related software documentation.

The sections in this document that correspond to sections in the *Fast Serial Interface Processor (FSIP) Installation and Configuration* publication include the following:

Sections in this document...

- Product Description, page 2
- Installation Prerequisites, page 7
- Configuring the Interfaces, page 8
- Reference Information, page 11

Sections in the FSIP document...

- Product Description, page 2
- Installation Prerequisites, page 14
- Configuring the FSIP, page 31
- Reference Information, page 48



Caution If you are installing a new E1-G.703/G.704 interface in an installed system, ensure that your system configuration meets the minimum requirements for the new interfaces. Refer to the section “Software Prerequisites” on page 7 for a description of these prerequisites.

Product Description

The E1-G.703/G.704 interface mounts on the FSIP and connects Cisco 7000 series and Cisco 7500 series routers with 2.048-Mbps leased-line services. The E1-G.703/G.704 interface supports both framed and unframed modes of operation, a loopback test, and a four-bit cyclic redundancy check (CRC). The interface can operate with either a line-recovered or an internal clock signal.

The E1-G.703/G.704 interface eliminates the need for a separate, external data termination unit to convert a standard serial interface (such as V.35) to a G.703/G.704/G.732 interface.

Two versions of the E1-G.703/G.704 interface are available: one supports balanced mode, and the other supports unbalanced mode.

The FSIP uses special serial port adapters and port adapter cables. A port adapter is a daughter card that provides the physical interface for two serial interface ports. Both ports on each port adapter use the same connector type: either a high-density, 60-pin universal port that supports all data communications interfaces (Electronics Industries Association/Telecommunications Industry Association (EIA/TIA)-232, EIA/TIA-449, V.35, X.21, and EIA-530), or a 15-pin port that supports the E1-G.703/G.704 telecommunications interface. Figure 1 shows the layout of the FSIP with port adapters installed. Figure 2 shows both the universal and E1-G.703/G.704 interface port adapters.

The FSIP can be configured to support up to eight E1-G.703/G.704 ports (four ports per module, two modules per FSIP). FSIP bandwidth can be allocated by the user, and the maximum aggregate bandwidth per four-port module is 16 Mbps, full duplex. We recommend that you leave one port on each module shut down to avoid exceeding this 16-Mbps maximum per module. Each of the four interfaces can operate up to 2.048 Mbps, which potentially presents a load greater than 16 Mbps, full duplex, if all four interfaces are configured. Eight E1-G.703/G.704 ports can be supported up to the 16-Mbps aggregate bandwidth capability; however, it is not possible to simultaneously support eight E1-G.703/G.704 ports at 100-percent peak bandwidth utilization without exceeding the 16-Mbps maximum per module.

Figure 1 Fast Serial Interface Processor

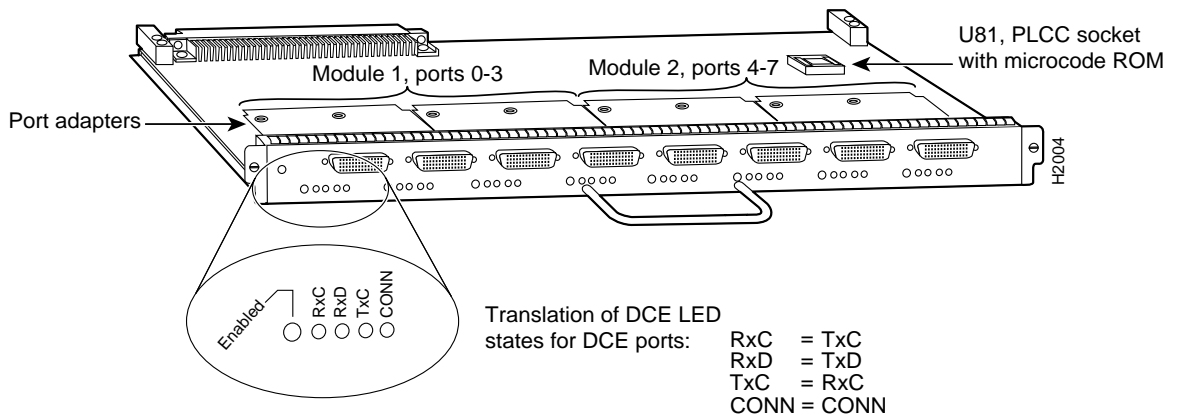

If you need to install or replace an E1-G.703/G.704 port adapter on your FSIP, refer to the section “Replacing Port Adapters” on page 42 of the *Fast Serial Interface Processor (FSIP) Installation and Configuration* publication (Document Number 78-1047-03, or later) for instructions.

The following sections provide an overview of G.703 operation and describe the configuration options on the E1-G.703/G.704 interface.

Figure 2 FSIP Universal and E1-G.703/G.704 Port Adapters

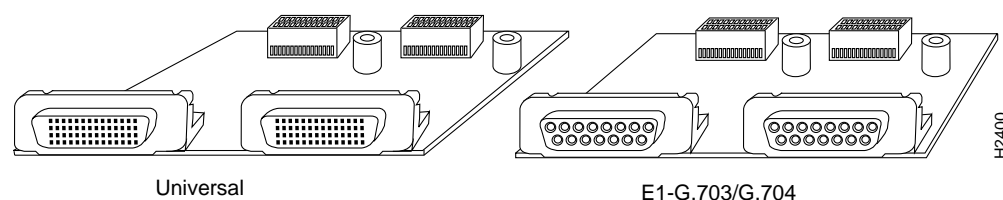

E1-G.703/G.704 Overview

G.703 is an International Telecommunication Union Telecommunication Standardization Sector (ITU-T) electrical and mechanical specification for connections between telecommunications interfaces and data communications equipment (DTE).

Note The ITU-T carries out the functions of the former Consultative Committee for International Telegraph and Telephone (CCITT).

Typically, G.703 provides a means of connecting standard serial interfaces such as V.35 to telephone lines or Postal Telephone and Telegraph (PTT) networks.

The E1-G.703/G.704 port adapter supports point-to-point connections to Cisco 7000 series and Cisco 7500 series routers from 2.048-Mbps, E1 leased-line services, and eliminates the need for a separate, external data termination unit that is typically used to convert standard serial interfaces, such as V.35, to E1-G.703/G.704.

Balanced and Unbalanced Modes

The E1-G.703/G.704 interface is available in either balanced or unbalanced mode. A unique port adapter supports each type. Neither the modes nor the cables are interchangeable; you cannot configure a balanced port to support an unbalanced line, nor can you attach an interface cable intended for a balanced port to an unbalanced port.

Balanced interfaces typically use three conductors and three signal states: high, low, and ground. The high and low signals mirror each other. Unbalanced interfaces use only two signals: signal and ground.

In addition to the agency approval label on each FSIP port, the **show controller cbus** command shows the mode of each interface. Following is an example:

```
Router# show controllers cbus

Switch Processor 5, hardware version 11.1, microcode version 1.4
[text omitted from example]
FSIP 1, hardware version 1.0, microcode version 1.0
Interface 8 - Serial1/0, electrical interface is E1-G.703, balanced
[text omitted from example]
Interface 9 - Serial1/1, electrical interface is E1-G.703, balanced
[remainder of displayed text omitted from example]
```

Framed and Unframed Operation

The E-G.703 interface is divided into 32 time slots or *frames*. (See Figure 3.) Each of the 32 time slots is an 8-bit frame that transmits data at 64 kbps. Each of these time slots can be configured to carry data or to remain empty. (The E1-G.703/G.704 port adapter inserts an idle pattern into empty time slots.)

Time slot 0, or the first 8 bits, is reserved as overhead. The remaining 248 bits (31 frames with 8 bits each) are designated time slots 1 through 31. Time slot 16 is also designated as a framing slot when using framed mode. When you use unframed mode (G.703), the default, you can configure time slot 16 to carry data and operate as any of the other slots; therefore, in framed mode time slot 0 must be designated as a framing signal; time slot 16 can be configured for either data or framing.

Unframed mode uses all 32 time slots for data (data is also called *payload*). None of the 32 time slots are used for framing signals. This allows each of the 32 time slots to transmit at 64 kilobits per second (kbps). (For example, 32 time slots x 64 kbps = 2.048 Mbps.)

Figure 3 Time Slot Diagram

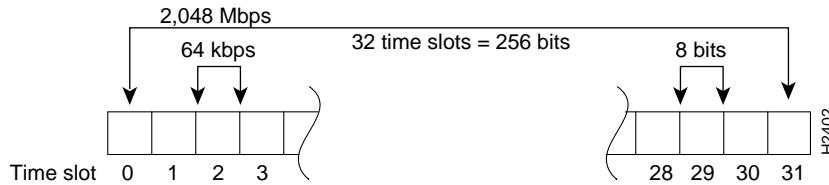

Framed mode (G.704) allows you to specify a bandwidth for the interface by designating a number of the 32 time slots for data, and reserves others for framing (timing). When you use framed mode, you must designate start and stop time slots; the slots within these boundaries are used for data, and the remaining slots are left idle. For example, on an interface with framing set on time slots 1 through 8, the interface will carry data within the specified 8 frames, and frames 9 through 31 will remain idle. Because each time slot transmits at 64 kbps, the interface will operate at 512 kbps (8 frames x 64 kbps = 512 kbps).

By configuring 16 of the time slots to carry data and the remaining 16 to remain empty, you can essentially configure the interface for 1.024 Mbps (by leaving half the time slots empty and unable to carry data). The FSIP inserts an idle pattern into unused time slots to identify them as overhead (unused for data). Only one contiguous time slot range can be used.

In PABX systems, time slot 16 is always left unused. By default, time slot 16 is *not* enabled for data in the FSIP E1-G.703/G.704 interface. Time slot 16 is used for data if it is included in the specified range of data slots. Also, the command **timeslot 16** overrides the default and enables time slot 16 to carry data.

Unframed mode is the default, and you can also specify unframed mode with the command **timeslot 0**, which specifies time slot 0 as the start slot with no stop (ending) time slot; therefore, all slots are used for data. The **no timeslot** command also restores the default of unframed mode.

CRC4

Framed mode supports a four-bit CRC, which you enable with a software command. The default is for no CRC. Refer to the section “Configuring CRC-4” on page 9.

Clock Source

The E1-G.703/G.704 interface does not operate in the DTE and data communications equipment (DCE) modes that are typical of data communications interfaces. The E1-G.703/G.704 interface operates with either a line-recovered or an internal clock signal. The default is for a line clock signal that the interface recovers from the received data stream. The interface can also operate with an internal clock signal. The E1-G.703/G.704 port adapter generates the internal clock signal; the interface does not use the FSIP clock. Because the E1-G.703/G.704 interfaces operate at a default clock rate of 2.048 Mbps (E1 speed), we recommend that you leave one port on each module shut down to avoid exceeding the 8 Mbps maximum for each module.

E1-G.703/G.704 Port Adapters and Cables

The FSIP is configured at the factory with from one to four E1-G.703/G.704 interface port adapters. Each port adapter provides two 15-pin, D-shell (DB-15) receptacles, which support only E1-G.703/G.704 interfaces. (See Figure 4.)

Figure 4 FSIP E1-G.703/G.704 Port Adapter

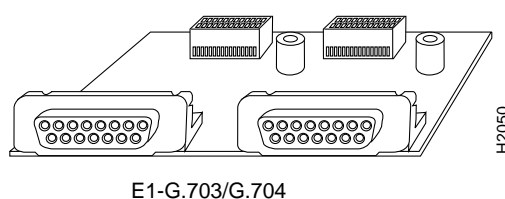

The FSIP uses a DB-15 receptacle for both the balanced and unbalanced ports. The label adjacent to the port indicates whether the port is balanced or unbalanced; you must connect the correct type of interface cable or the port will not operate.

The following sections describe the port adapters and cables for data communications and the E1-G.703/G.704 interfaces.

The FSIP end of all E1-G.703/G.704 adapter cables is a DB-15 connector. At the network end, the adapter cable for unbalanced connections uses a BNC connector. The adapter cables for balanced mode are available with several connector types to accommodate connection standards in different countries.

You must use the proprietary cables to connect the E1-G.703/G.704 port to your network. Cables for balanced and unbalanced mode are available with the following types of network-end connectors:

- Unbalanced (75 ohm) coaxial cables with BNC connectors at the network end (used primarily for connection in the United Kingdom); see Figure 5
- Balanced (120 ohm) with a DB-15 connector at the network end; see Figure 6
- Balanced (120 ohm) twinaxial split cable at the network end, with separate transmit and receive cables, each with a twinax connector; see Figure 7

In addition to these cables, some connections require bare-wire connections (directly to terminal posts).

Port Adapter and Cable Model Numbers

Table 1 lists the model numbers and descriptions of the E1-G.703/G.704 port adapters and cables.

Table 1 Model Numbers and Descriptions of E1-G.703/G.704 Port Adapters and Cables

Port Adapter and Cable Model Numbers	Description
PA-7KF-E1/120= ¹	Dual-port E1-G.703/G.704, 120 ohm, balanced
PA-7KF-E1/75=	Dual-port E1-G.703/G.704, 75 ohm, unbalanced
CAB-E1-TWINAX=	E1 cable, TWINAX, 120 ohm, balanced, 5 m
CAB-E1-DB15=	E1 cable, DB-15, 120 ohm, balanced, 5 m
CAB-E1-BNC=	E1 cable, BNC, 75 ohm, unbalanced, 5 m

1. The appended equal sign (=) indicates a spare part.

FSIP LEDs

The E1-G.703/G.704 interfaces use the same FSIP LEDs as all the other FSIP serial interfaces. Table 2 shows the LED states (for both balanced and unbalanced ports).

Table 2 FSIP LED Indicators

LED	E1-G.703/G.704 Signal
RxC	Receive Clock (from network)
RxD	Receive Data (from network)
TxC	Send Timing (from network)
CONN	Connected

Installation Prerequisites

In addition to the prerequisites described in the *FSIP Installation and Configuration* publication, ensure that your existing system components meet the compatibility requirements described in this section. Also, read the list of parts and tools you will need to perform the installation, and the safety and ESD-preventive guidelines for avoiding bodily injury or equipment damage.

Distance Limitations

Unbalanced G.703 interfaces allow for a longer maximum cable length than those specified for balanced circuits. Table 3 lists the maximum cable lengths for each FSIP E1-G.703/G.704 cable type by the connector used at the network (non-FSIP) end.

Table 3 E1-G.703/G.704 Maximum Cable Lengths

Connection Type	BNC	Twinax
Balanced	–	300 m
Unbalanced	600 m	–

Software Prerequisites

Before installing an FSIP with E1-G.703/G.704 interfaces in your Cisco 7000 series or Cisco 7500 series router, ensure that your current system software is one of the following:

- Maintenance Release 9.17(10) or a later
- Cisco Internetwork Operating System (Cisco IOS) Release 10.2 or later (or a later maintenance release of Cisco IOS Release 10.2)

Note The E1-G/703/G.704 interface is incompatible with Software Release 9.21 and Software Release 10.0 images. The Switch Processor (SP) or Silicon Switch Processor (SSP) in your system must contain microcode version 1.4 or later in read-only memory (ROM). Refer to the FSIP document for additional FSIP prerequisites.

- The FSIP with E1-G.703/G.704 interfaces operates with any of the Cisco IOS releases running in the currently shipping Cisco 7500 series routers: Cisco 7505, Cisco 7507, and Cisco 7513.

Cable Connections

Figure 5, Figure 6, and Figure 7 show the unbalanced and balanced cables used for connection between the E1-G.703/G.704 port adapter and your network. The port-adapter end of each cable has a DB-15 connector.

Figure 5 E1-G.703/G.704 Interface Cable for Unbalanced Connections (with BNC Connectors and Coaxial Cables)

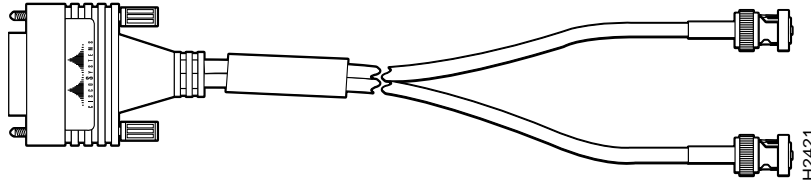

Figure 6 E1-G.703/G.704 Interface Cable for Balanced Connections (with DB-15 Connectors on Both Ends)

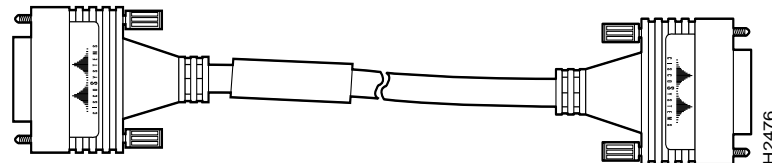
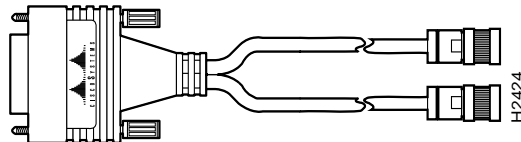

Figure 7 E1-G.703/G.704 Interface Cable for Balanced Connections (with Twinax Connectors and Cables)



Caution It is a requirement of the statutory approval of the E1-G.703/G.704 interface that the jackscrews of the connector backshell are securely screwed down while the FSIP is operating.

Configuring the Interfaces

This section describes the commands for configuring individual interfaces for framed or unframed mode, four-bit CRC, and loopback, and for specifying a clock source.

After you verify that the new FSIP is installed correctly (the enabled LED goes on), use the privileged-level **configure** command to configure the new interfaces.

Be prepared with the information you will need, such as the following:

- Timing source for each new interface (a line-derived or internal clock signal)
- Whether you will use framed or unframed mode on E1-G.703/G.704 interfaces

The following are the default settings for all E1-G.703/G.704 interfaces; each can be enabled or disabled with software commands:

- Unframed mode
- No CRC enabled
- Time slot 16 is not used for payload
- No loopback
- Clock source operation (line or internal)



Caution Always issue a **clear interface** command after altering the configuration of an interface, particularly after changing a time slot or CRC4 setting.

Configuring Framed and Unframed Mode

The E1-G.703/G.704 interfaces support both framed (G.704) and unframed (G.703) modes of operation; the default is unframed operation. To enable framed operation, you must specify the start and stop slots, separated by a hyphen, as follows:

```
[no] timeslot 0/start-slot-31/stop_slot
```

Following is a sample display of the **timeslot** command with a start slot of 1 and a stop slot of 13:

```
router# timeslot 1-13
```

Nonsensical combinations of start and stop slots will be ignored, and the interface will be left unchanged.

The system default is not to use time slot 16 for data. To use slot 16 for data, use the **timeslot 16** command. To restore the system default, use the **no timeslot 16** command.

Configuring Timing (Clock) Signals

The E1-G.703/G.704 port operates either with an external clock signal that it recovers from the received data stream (the default clocking) or its own internal clock signal. To specify the clock source, use the **clock source {line | internal}** command.

To change the default and use the internal clock, use the **clock source internal** command.

To return the interface to the default state, use the **clock source line** command. (You can also negate either of these commands to change a setting; for example, the **no clock source internal** command also returns the interface to the default state.) All E1-G.703/G.704 interfaces operate at a default clock rate of 2.048 Mbps; the clock rate cannot be configured.

Configuring CRC-4

CRC-4 is a 4-bit error checking technique that uses a calculated numeric value to perform an ongoing data integrity check and detect errors in transmitted data. (Refer to *Fast Serial Interface Processor (FSIP) Installation and Configuration* for a description of CRCs.) The E1-G.703/G.704 interface supports CRC in framed mode only. By default, CRC-4 is not enabled.

To enable CRC4 on the E1 interface, specify the slot and port address of the interface followed by the command **crc4**. press **Ctrl-Z** after altering the configuration and before exiting the configuration mode. In the example that follows, the top port on an FSIP in interface processor slot 3 is configured for CRC:

```
Router# configure terminal
interface serial 3/0
crc4
^Z
```

To disable CRC and return to the default of no CRC error checking, specify the slot and port address and use the **no crc4** command. For complete command descriptions and instructions, refer to the *Router Products Configuration Guide* and *Router Products Command Reference* publications.

Alarms

Following are definitions and descriptions of the five alarms used with the E1-G.703/G.704 interface:

- **AIS**—The alarm indication signal occurs and a failure is declared (for E1 links) when 64 consecutive ones occur on the Receive Data (RD) line between the applique and the FSIP.
- **RAI**—The remote alarm indication (also called the *far end alarm* and *distant alarm* for E1 links) is sent by the remote end of the link to indicate failure at the remote end. This failure is declared (for E1 links) when 32 contiguous pulse positions have no pulses of either positive or negative polarity.
- **LOS**—The loss of signal alarm occurs and a failure is declared (for E1 links) when more than ten consecutive zeroes are detected.
- **LOF**—The loss of frame alarm occurs and a failure is declared (for E1 links) when an out-of-frame (OOF) defect has persisted for T seconds, where $2 \leq T \leq 10$. This failure is cleared when there have been no OOF defects during a period T seconds, where $0 \leq T \leq 20$.
- **SQ**—The signal quality alarm occurs and a failure is declared (for E1 links) when the bit error rate (BER) is greater than 10^{-3} on the RD line between the applique and the FSIP.

Loopback

The E1-G.703/G.704 interface supports the same local loopback test as the other (data communications) FSIP interfaces. Loopback functions enable you to check the integrity of the physical data path between the FSIP and the E1 port adapter with the **loopback** command. The **no loopback** command disables all loopback tests on the interface.

Because the E1-G.703/G.704 interfaces uses a default clock rate of 2.048 Mbps, you do not have to configure a clock signal on the interface before performing a loopback test.

The **loopback** command tests the path between the FSIP and the interface port (without leaving the FSIP and port adapter). On the E1 port adapter, the loopback signal follows this path regardless of whether or not a cable is attached to the port. Figure 8 shows the path of the loopback function.

Figure 8 Loopback Path for FSIP E1-G.703/G.704

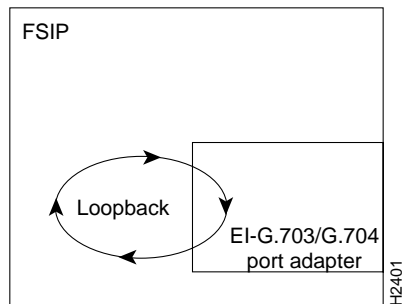

Reference Information

This reference section describes the **show** command that you can use to verify the current system status and configuration. It also lists cable pinouts for the port adapter cables.

Command Descriptions and Examples

The **show controllers cxbus** command displays the interface type on each FSIP port. The display for E1-G.703/G.704 interfaces indicates whether the interface is balanced or unbalanced.

In the following example of the **show controllers cxbus** command display, the interfaces on the first two ports (0 and 1) are balanced interfaces.

```
Router# show controllers cxbus
Switch Processor 5, hardware version 11.1, microcode version 1.4
[text omitted from example]
FSIP 1, hardware version 1.0, microcode version 1.0
Interface 8 - Serial1/0, electrical interface is g.703 balanced
[text omitted from example]
Interface 9 - Serial1/1, electrical interface is g.703 balanced
[remainder of displayed text omitted from example]
```

E1-G.703/G.704 Port Adapter and Cable Pinouts

Table 4 shows the signal pinouts for each type of E1-G.703/G.704 interface cable. All cables use a DB-15 connector at the FSIP end.

Table 4 E1-G.703/G.704 Adapter Cable Connector Pinouts

FSIP End		Network End				
DB-15 ¹		DB-15	Null Modem DB-15	BNC	Twinax	
Pin	Signal ²	Pin	Pin	Signal	Pin	Signal
9	Tx tip	1	3	Tx tip	Tip	Tx tip
2	Tx ring	9	11	Tx shield	Ring	Tx ring
10	Tx shield	2	4	–	Shield	Tx shield
8	Rx tip	3	1	Rx tip	Tip	Rx tip
15	Rx ring	11	9	Rx shield	Ring	Rx ring
7	Rx shield	4	2	–	Shield	Rx shield

1. Any pins not described in Table 4 are not connected.

2. Tx = transmit. Rx = receive.

Cisco Information Online

Cisco Information Online (CIO) is Cisco Systems' primary, real-time support channel. Maintenance customers and partners can self-register on CIO to obtain additional content and services.

Available 24 hours a day, 7 days a week, CIO provides a wealth of standard and value-added services to Cisco's customers and business partners. CIO services include product information, software updates, release notes, technical tips, the Bug Navigator, configuration notes, brochures, descriptions of service offerings, and download access to public and authorized files.

CIO serves a wide variety of users through two interfaces that are updated and enhanced simultaneously—a character-based version and a multimedia version that resides on the World Wide Web (WWW). The character-based CIO (called "CIO Classic") supports Zmodem, Kermit, Xmodem, FTP, Internet e-mail, and fax download options, and is excellent for quick access to information over lower bandwidths. The WWW version of CIO provides richly formatted documents with photographs, figures, graphics, and video, as well as hyperlinks to related information.

You can access CIO in the following ways:

- WWW: <http://www.cisco.com>.
- Telnet: [cio.cisco.com](telnet://cio.cisco.com).
- Modem: From North America, 408 526-8070; from Europe, 33 1 64 46 40 82. Use the following terminal settings: VT100 emulation; databits: 8; parity: none; stop bits: 1; and baud rates up to 14.4 kbps.

For a copy of CIO's Frequently Asked Questions (FAQ), contact cio-help@cisco.com. For additional information, contact cio-team@cisco.com.

Note If you are a network administrator and need personal technical assistance with a Cisco product that is under warranty or covered by a maintenance contract, contact Cisco's Technical Assistance Center (TAC) at 800 553-2447, 408 526-7209, or tac@cisco.com. To obtain general information about Cisco Systems, Cisco products, or upgrades, contact 800 553-6387, 408 526-7208, or cs-rep@cisco.com.

This document is to be used in conjunction with the *Cisco 7000 Hardware Installation and Maintenance*, *Cisco 7010 Hardware Installation and Maintenance*, *Cisco 7505 Hardware Installation and Maintenance*, *Cisco 7507 Hardware Installation and Maintenance*, and *Cisco 7513 Hardware Installation and Maintenance* publications. (1385g703.fm)

Catalyst, CD-PAC, CiscoFusion, Cisco IOS, CiscoPro, CiscoView, CiscoVision, CiscoWorks, ControlStream, DesignDirector, EtherChannel, HubDirector, HubSwitch, LAN²LAN, LAN²LAN Enterprise, LAN²LAN Remote Office, LAN²PC, Newport Systems Solutions, *Packet*, PC²LAN/X.25, Point and Click Internetworking, RouteStream, SMARTnet, SwitchProbe, SynchroniCD, *The Cell*, TrafficDirector, VirtualStream, VlanDirector, WNIC, Workgroup Director, Workgroup Stack, and XCI are trademarks, Access by Cisco and Bringing the power of internetworking to everyone are service marks, and Cisco, Cisco Systems, the Cisco Systems logo, EtherSwitch, IGRP, Kalpana, LightStream, and UniverCD are registered trademarks of Cisco Systems, Inc. All other trademarks, service marks, registered trademarks, or registered service marks mentioned in this document are the property of their respective owners.

Copyright © 1995, Cisco Systems, Inc.
All rights reserved. Printed in USA
959R

