



Doc. No. 78-2562-01

7000 Series Chassis Interface (RSP7000CI) Replacement in the Cisco 7000 Series Routers

Product Number RSP7000CI=

This document contains instructions for replacing the 7000 Series Chassis Interface (RSP7000CI) in the Cisco 7000 series routers: the Cisco 7000 and Cisco 7010. The RSP7000CI provides all of the environmental monitoring functions for the Cisco 7000 series router and is a required system component in a Cisco 7000 series chassis configured with the RSP7000.

In the Cisco 7000, the RSP7000CI is installed in the 7000 CI slot (slot 6 in the Cisco 7000 and slot 4 in the Cisco 7010) on the interface processor end of the Cisco 7000 series chassis.

Note This document discusses the replacement of an RSP7000CI in a Cisco 7000 series chassis that has already been configured with a 7000 Route Switch Processor (RSP7000) and an RSP7000CI.

If you have a Cisco 7000 series chassis with a Route Processor (RP) and Switch Processor (SP) (or Silicon Switch Processor [SSP]) installed, in slots 6 and 5 respectively, *do not attempt to install the RSP7000CI*. You will need to upgrade the chassis with an RSP7000 before you install the RSP7000CI. Refer to the note at the end of this document, and contact a service representative or the Cisco Technical Assistance Center (TAC) for information on how to proceed.

The RSP7000CI operation requires that your Cisco 7000 series router has an RSP7000 installed, and is running Cisco Internetwork Operating System (Cisco IOS) Release 10.3(9), or later, Release 11.0(6), or later, or Release 11.1(1) or later.

The sections in this document include the following:

- Product Overview, page 2
- Prerequisites, page 4
- Replacing the RSP7000CI, page 6
- Checking the Installation, page 10
- Cisco Information Online, page 13

Product Overview

Following are brief descriptions of the Cisco 7000 series routers and the RSP7000CI.

What Is the Cisco 7000?

The Cisco 7000 is a seven-slot router chassis, which uses the new RSP7000 kit. The Cisco 7000 provides up to five interface processor slots, and can accommodate the following CxBus-based interface processors: Fast Ethernet, Ethernet, Token Ring, Fiber Distributed Data Interface (FDDI), channel attachment, multichannel, serial, and so forth. The RSP7000, RSP7000CI, and interface processors are keyed with guides on the backplane to prevent them from being fully inserted in the wrong slot.

Figure 1 shows the rear of the Cisco 7000 router. In the Cisco 7000, slot 6 is reserved for the RSP7000CI board, which contains all of the environmental monitoring functions for the Cisco 7000, when configured with the new 7000 RSP. The remaining six slots (0 through 5) are for interface processors and the RSP7000.

Figure 1 Cisco 7000 with RSP7000 and RSP7000CI Installed

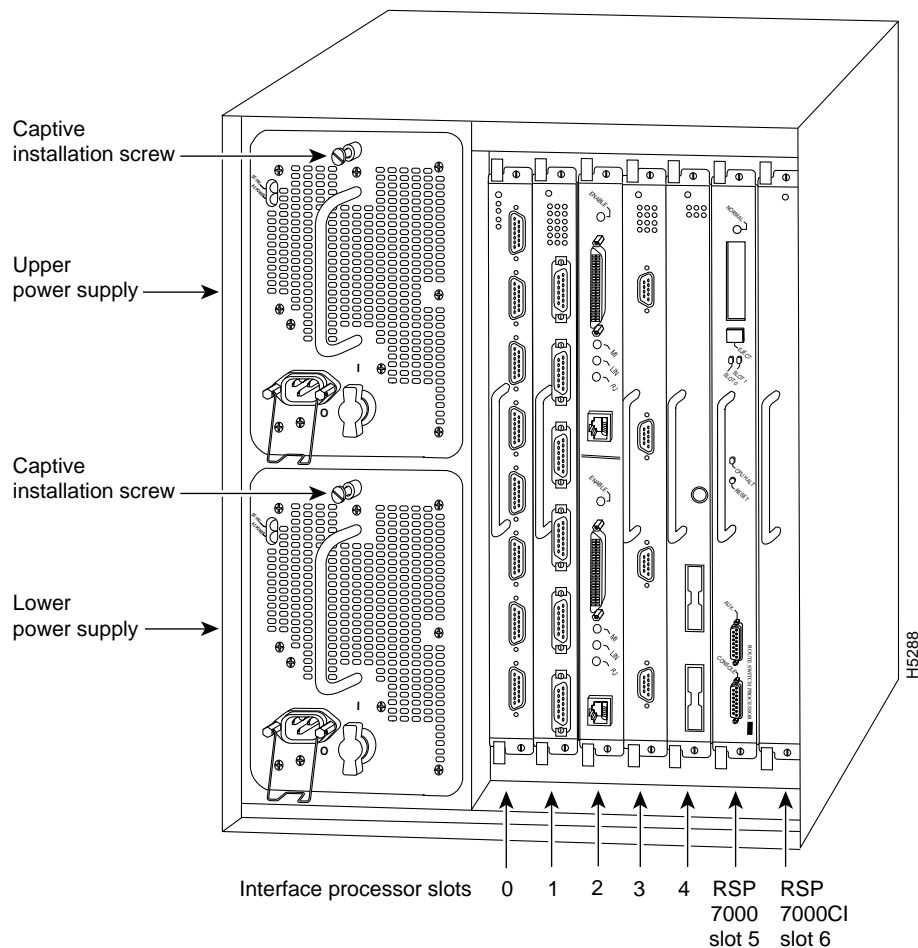

What Is the Cisco 7010?

The Cisco 7010 is a five-slot chassis, which uses the new RSP7000CI (and the RSP7000), and provides up to three interface processor slots that can accommodate the following CxBus-based interface processors: Fast Ethernet, Ethernet, Token Ring, Fiber Distributed Data Interface (FDDI), channel attachment, multichannel, serial, and so forth. The processor and interface processors are keyed with guides on the backplane to prevent them from being fully inserted in the wrong slot.

Figure 2 shows the rear of the Cisco 7010 router with the RSP7000CI and RSP7000 installed. In the Cisco 7010, slot 4 is reserved for the RSP7000CI, which contains all of the environmental monitoring functions for the Cisco 7010. The remaining three slots (slots 0 through 2) are for interface processors.

Figure 2 Cisco 7010 with RSP7000 and RSP7000CI Installed

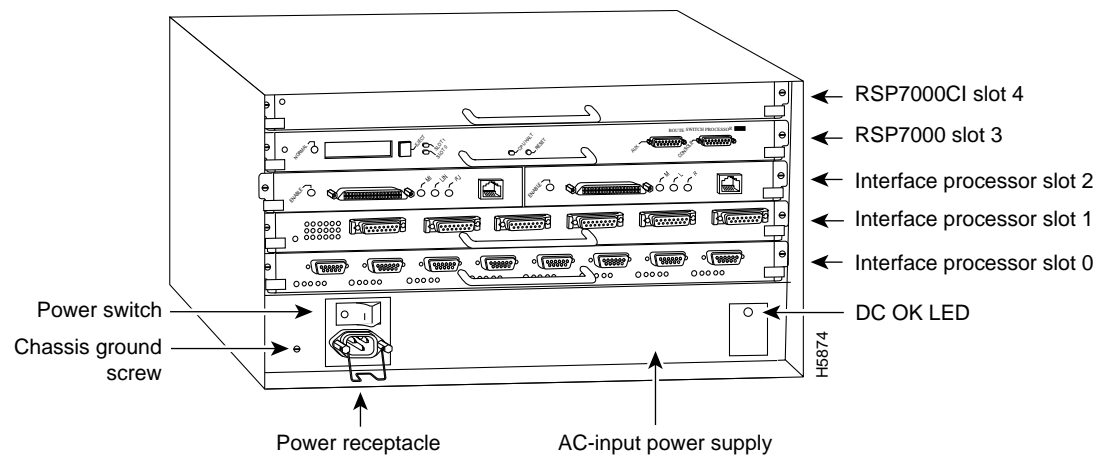

What is the RSP7000CI?

The RSP7000CI, shown in Figure 3 on page 4, consists of a printed circuit board attached to a metal carrier. The RSP7000CI provides the environmental monitoring and power supply monitoring functions for the Cisco 7000 series chassis. The RSP7000CI isolates the CPU and system software from chassis-specific variations. The RSP7000CI has no user-configurable jumpers or switches, and its faceplates contains no LEDs. The RSP7000CI is distinguishable only by the label on its faceplate, which reads *7000 Chassis Interface*.

You must install the RSP7000CI in the appropriate chassis' 7000 CI slot. (See Figure 1 on page 2, for the Cisco 7000, or Figure 2 on page 3 for the Cisco 7010.) For the appropriate Cisco IOS version required for the RSP7000CI, refer to the section "Preventing Electrostatic Discharge Damage" on page 5.

The functions of the RSP7000CI are as follows:

- Report backplane and arbiter type
- Monitor power supply status
- Monitor fan/blower status
- Monitor temperature sensors on the RSP7000
- Provide router power up/down control
- Provide power supply power-down control

Figure 3 RSP7000CI

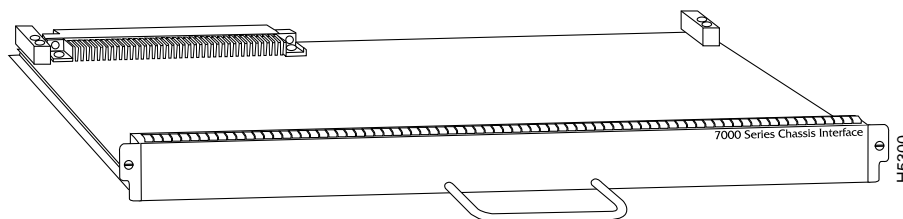

Caution To prevent system problems, the RSP7000CI must not be removed with power on to the chassis. The RSP7000CI does not support online insertion and removal (OIR).

Prerequisites

Before you begin this installation, review the safety guidelines in this section to avoid injuring yourself or damaging the equipment.

Safety Guidelines

Following are safety guidelines that you should follow when working with any equipment that connects to electrical power or telephone wiring.

Electrical Equipment Guidelines

Follow these basic guidelines when working with any electrical equipment:

- Before beginning any procedures requiring access to the chassis interior, locate the emergency power-off switch for the room in which you are working.
- Disconnect all power and external cables before moving a chassis.
- Do not work alone when potentially hazardous conditions exist.
- Never assume that power has been disconnected from a circuit; always check.
- Do not perform any action that creates a potential hazard to people or makes the equipment unsafe.
- Carefully examine your work area for possible hazards such as moist floors, ungrounded power extension cables, and missing safety grounds; correct all hazardous conditions.

Telephone Wiring Guidelines

Use the following guidelines when working with any equipment that is connected to telephone wiring or to other network cabling:

- Never install telephone wiring during a lightning storm.
- Never install telephone jacks in wet locations unless the jack is specifically designed for wet locations.
- Never touch uninsulated telephone wires or terminals unless the telephone line has been disconnected at the network interface.
- Use caution when installing or modifying telephone lines.

Preventing Electrostatic Discharge Damage

Electrostatic discharge (ESD) damage, which can occur when electronic cards or components are improperly handled, results in complete or intermittent failures. Electromagnetic interference (EMI) shielding and connectors are integral components of the carrier. Use a preventive antistatic strap whenever handling a processor module.

Following are guidelines for preventing ESD damage:

- Always use an ESD wrist or ankle strap and ensure that it makes good skin contact.
- Connect the equipment end of the strap to a captive installation screw on an installed power supply.
- Handle components by the edges only; avoid touching the board or connectors.
- Place a removed component on an antistatic surface or in a static shielding bag. If you plan to return the component to the factory, immediately place it in a static shielding bag.
- Avoid contact between the component and clothing. The wrist strap only protects the board from ESD voltages on the body; ESD voltages on clothing can still cause damage.



Caution For safety, periodically check the resistance value of the antistatic strap. The measurement should be between 1 and 10 megohms.

Software and Hardware Prerequisites

The RSP7000CI is compatible with any Cisco 7000 series routers that is operating with the following software and hardware:

- The current system software must be Cisco IOS Release 10.3(9), or later, Release 11.0(6), or later, or Release 11.1(1) or later.
- You must install the RSP7000CI in the appropriate chassis' 7000 CI slot. (See Figure 1 on page 2, for the Cisco 7000, or Figure 2 on page 3 for the Cisco 7010.)
- Using the RSP7000CI requires that the RSP7000 is also installed in the Cisco 7000 series router.

The **show version** command displays the current hardware configuration of the router, including the Cisco IOS release that is currently loaded and running. The **show controllers cbus** command lists all CxBus interfaces installed in the system.



Caution To prevent system problems, the RSP7000CI must not be removed with power ON to the chassis. The RSP7000CI does not support online insertion and removal (OIR).

List of Tools and Parts

Following are the tools and equipment that you will need to complete this replacement:

- ESD-prevention equipment (a disposable wrist strap is included with all spares and upgrade kits)
- Antistatic mat, foam pad, or bag for the removed RSP7000CI (immediately place a removed board into an antistatic bag if you plan to return it to the factory)
- Number 2 Phillips or 3/16-inch flat-blade screwdriver for loosening the captive installation screws on the faceplate of the RSP7000CI
- A new RSP7000CI board

Replacing the RSP7000CI

Following are the replacement procedures for replacing an RSP7000CI in your Cisco 7000 series router. You must turn off all system power before replacing the RSP7000CI.



Caution To prevent system problems, the RSP7000CI must not be removed with power ON to the chassis. The RSP7000CI does not support online insertion and removal (OIR).

Removing the RSP7000CI

Remove the existing RSP7000CI as follows:

- Step 1** If you have not already done so, slip on an ESD-prevention grounding strap. (A disposable wrist strap is included with all spare boards.) Connect the equipment end of the strap to an unpainted surface on the chassis.
- Step 2** Locate the RSP7000CI, which is installed in the 7000 CI slot (slot 6 in a Cisco 7000 and slot 4 in a Cisco 7010. (See Figure 1 or Figure 2.)

Figure 4 shows the orientation of the RSP7000CI for the Cisco 7000.

Figure 4 Card-Installation Orientation in the Cisco 7000

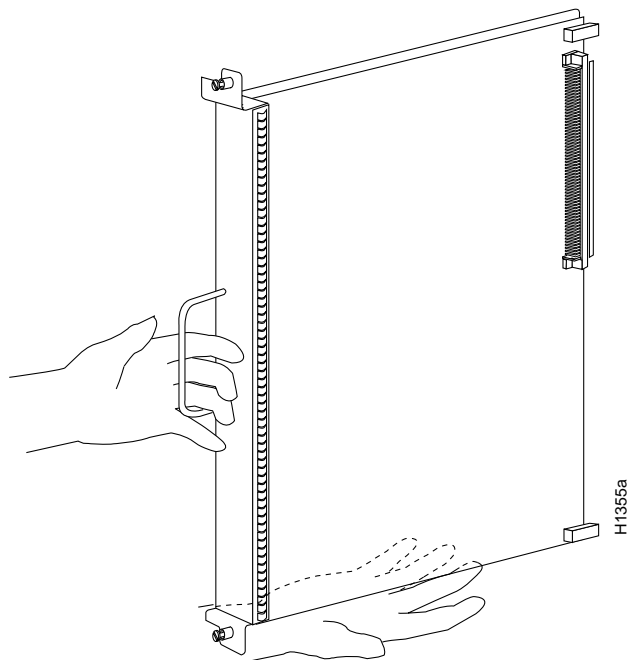
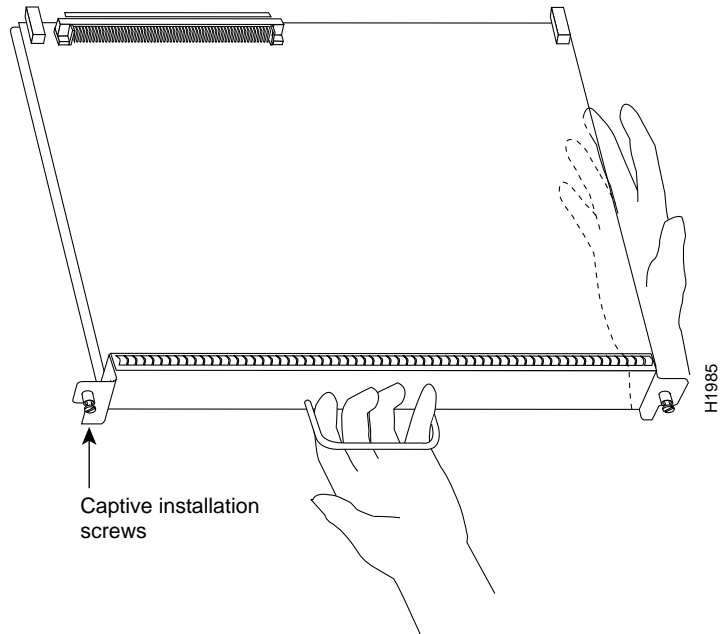

Figure 5 shows the orientation of the RSP7000CI for a Cisco 7010.

Figure 5 Card-Installation Orientation in the Cisco 7010



Step 3 Use a screwdriver (number 2 Phillips or 3/16-inch flat-blade) to loosen the two captive installation screws. (See Figure 6a.)

Note Figure 6 shows a typical processor module installation in a Cisco 7000, and is not intended to indicate or recommend a particular slot location for the RSP7000CI. The processor module slots in the Cisco 7010 are oriented horizontally (see Figure 2), but the function of the captive installation screws and ejector levers is identical.

Figure 6 Ejector Levers and Captive Installation Screw

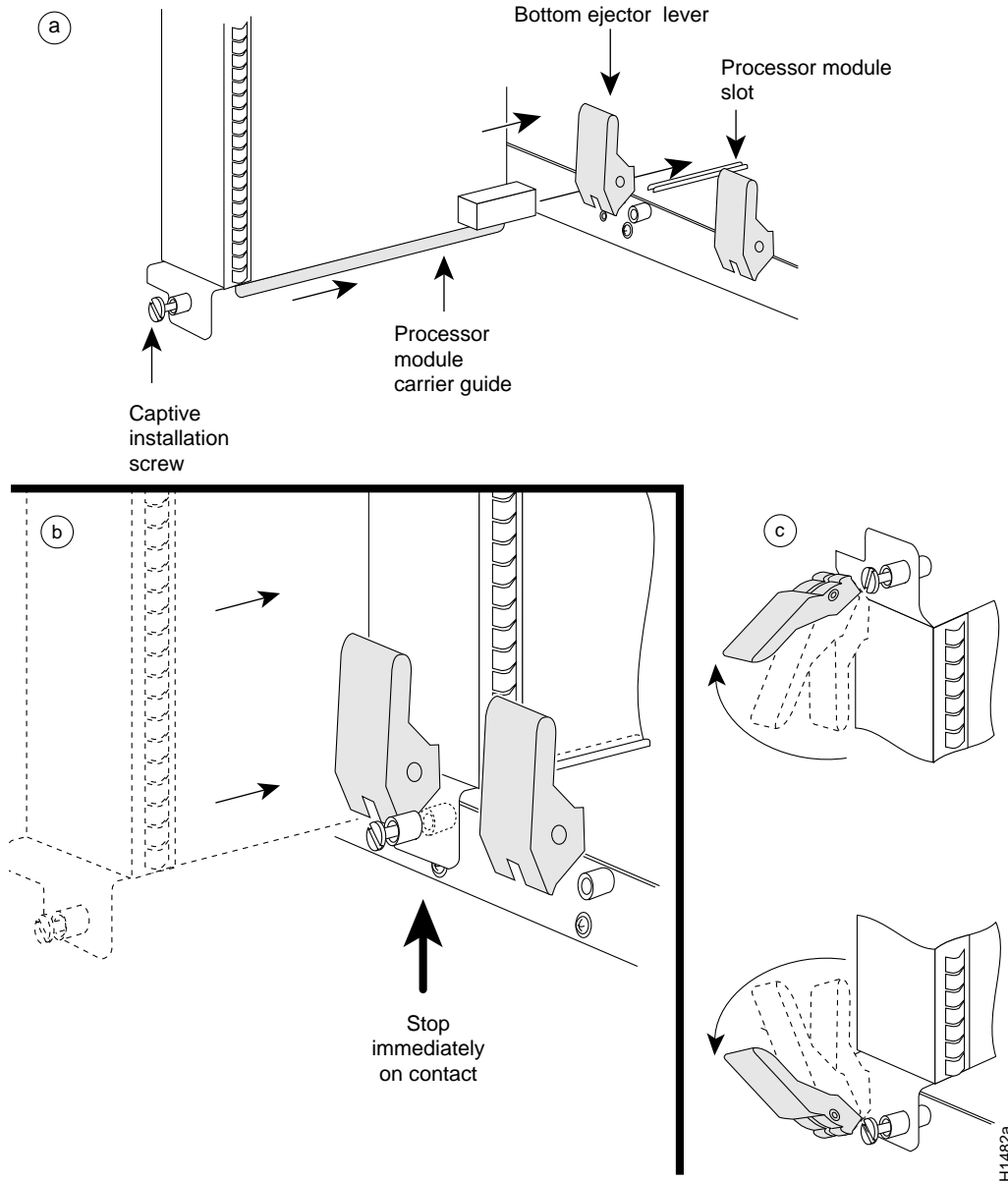

Step 4 Place your thumbs on the ends of each of the ejectors and simultaneously pull them both outward, away from the carrier handle (in the opposite direction from that shown in Figure 6c) to release the carrier from the slot and to dislodge the RSP7000CI from the backplane.

- Step 5** Grasp the handle with one hand and pull the RSP7000CI straight out of the slot (see Figure 6b), keeping your other hand under the carrier to guide it. Keep the carrier parallel to the backplane. Avoid touching the board or any connector pins.
- Step 6** Place the removed RSP7000CI on an antistatic mat or foam. If you plan to return the RSP7000CI to the factory, immediately place it in an antistatic bag to prevent ESD damage.

Proceed to the section “Installing the New RSP7000CI.”

Installing the New RSP7000CI

Ensure that all system power is turned off before installing the RSP7000CI in the chassis. The RSP7000CI is keyed for installation only in the RSP7000CI slot (slot 6). (See Figure 1 on page 2.)

Follow these steps to install an RSP7000CI:

- Step 1** Ensure that all power supplies are turned OFF.
- Step 2** Grasp the RSP7000CI handle with one hand and place your other hand under the carrier to support and guide it into the slot. Avoid touching the board or any connectors.
- Step 3** Place the back of the RSP7000CI in the 7000 CI slot (see Figure 1, on page 2, for the Cisco 7000 or Figure 2, on page 3, for the Cisco 7010) and align the notches along the edge of the carrier with the grooves in the slot. (See Figure 6a.)



Caution To prevent damage to the backplane, you must install the RSP7000CI in the 7000 CI slot of your Cisco 7000 series router. (See Figure 1 or Figure 2.) The slots are keyed for correct installation. Forcing the RSP7000CI into a different slot can damage the backplane and the RSP7000CI.

- Step 4** While keeping the RSP7000CI parallel to the backplane, carefully slide the carrier into the 7000 CI slot until the RSP7000CI faceplate makes contact with the ejector levers, then *stop*. (See Figure 6b.)
- Step 5** Using the thumb and forefinger of each hand to pinch each ejector, simultaneously push both ejectors inward (toward the handle) until they parallel to the faceplate. (See Figure 6c.)
- Step 6** Use a screwdriver (number 2 Phillips or 3/16-inch flat-blade) to tighten the captive installation screws on the ends of the RSP7000CI. (See Figure 6a.)
- Tighten the two captive screws on the RSP7000CI faceplate to prevent the RSP7000CI from becoming partially dislodged from the backplane and to ensure proper EMI shielding. (These screws must be tightened to meet EMI specifications.)
- Step 7** Ensure that the console terminal is connected to the console port on the RSP7000, and that the terminal is turned on.
- Step 8** Turn the system power back ON, and proceed to the next section to check the installation.

Checking the Installation

Verify RSP700CI is installed in the chassis' 7000 CI slot (see Figure 1 on page 2 or Figure 2 on page 3), and that both of the captive installation screws are tightened.

Using the RSP700CI and the temperature sensors on the RSP7000, the system displays warning messages on the console if chassis interface-monitored parameters exceed a desired threshold or if a blower failure occurs. You can retrieve and display environmental status reports with the **show environment**, **show environment all**, **show environment last** and **show environment table** commands. Parameters are measured and reporting functions are updated every 60 seconds. A brief description of each of these commands follows.

Use these **show** commands to indicate that the RSP700CI installation was successful.



Caution To prevent overheating the chassis, ensure that your system is drawing cool inlet air. Overtemperature conditions can occur if the system is drawing in the exhaust air of other equipment. Ensure adequate clearance around the sides of the chassis so that cooling air can flow through the chassis interior unimpeded. Obstructing or blocking the chassis sides will restrict the airflow and can cause the internal chassis temperature to exceed acceptable limits.

The **show environment** command display reports the current environmental status of the system. The report displays parameters that are out of the normal values. No parameters are displayed if the system status is normal. The example that follows shows the display for a system in which all monitored parameters are within Normal range.

Following is sample output of the **show env** command:

```
Router# show env

All measured values are normal
```

If the environmental status is *not* normal, the system reports the worst-case status level in the last line of the display.

The **show environment last** command retrieves and displays the NVRAM log showing the reason for the last shutdown (if the shutdown was related to voltage or temperature) and the environmental status at that time. Air temperature is measured and displayed, and the DC voltages supplied by the power supply are also displayed. An example of the **show env last** command follows for both the Cisco 7000 and Cisco 7010:

```
RSP7000#show env last
CI(6) Inlet          previously measured at 22C/71F
CI(6) Hotpoint      previously measured at 31C/87F
CI(6) Exhaust       previously measured at 23C/73F
+12 Voltage         previously measured at 12.12
+5 Voltage          previously measured at 5.13
-12 Voltage         previously measured at -11.84
+24 Voltage         previously measured at 24.06

RSP7010#show env last
CI(4) Inlet         previously measured at 23C/73F
CI(4) Hotpoint      previously measured at 35C/95F
CI(4) Exhaust       previously measured at 25C/77F
+12 Voltage         previously measured at 12.31
+5 Voltage          previously measured at 5.17
-12 Voltage         previously measured at -11.89
+24 Voltage         previously measured at 23.78
```

The **show environment table** command displays the temperature and voltage thresholds for each of the three RSP7000 temperature sensors, for each monitored status level: low critical, low warning, high warning, and high critical. The slots in which the RSP7000 can be installed are indicated in parentheses (2 and 3). Also listed are the shutdown thresholds for the processor boards and power supplies. An example of the **show env table** command follows for both the Cisco 7000 and Cisco 7010:

```
RSP7000#show env table
Sample Point      LowCritical      LowWarning      HighWarning
HighCritical
CI(6) Inlet              44C/111F        50C/122F
CI(6) Hotpoint          54C/129F        60C/140F
CI(6) Exhaust
+12 Voltage           10.90           11.61           12.82           13.38
+5 Voltage             4.61            4.94            5.46            5.70
-12 Voltage           -10.15          -10.76          -13.25          -13.86
+24 Voltage           20.38           21.51           26.42           27.65
2.5 Reference                2.43            2.51
Shutdown power supplies at 70C/158F

RSP7010#show env table
Sample Point      LowCritical      LowWarning      HighWarning
HighCritical
CI(4) Inlet              44C/111F        50C/122F
CI(4) Hotpoint          54C/129F        60C/140F
CI(4) Exhaust
+12 Voltage           10.90           11.61           12.82           13.38
+5 Voltage             4.61            4.94            5.46            5.70
-12 Voltage           -10.15          -10.76          -13.25          -13.86
+24 Voltage           20.38           21.51           26.42           27.65
2.5 Reference                2.43            2.51
Shutdown power supplies at 70C/158F
```

The **show environment all** command displays an extended report that includes the arbiter type, backplane type, power supply type (AC or DC), wattage and status, the number and type of intermittent power failures (if any) since the system was last powered on, and the currently measured values at the RSP7000 temperature sensors and the power supply voltages. An example of the **show env all** command follows for both the Cisco 7000 and Cisco 7010:

```
RSP7000#show env all
Arbiter type 1, backplane type 70x0 (id 5)
Power supply #1 is 700W (id 2), power supply #2 is removed (id 3)
Active fault conditions: none
Active trip points: none

                                0123456
Dbus slots: X X

card      inlet      hotpoint      exhaust
CI(6)     21C/69F      30C/86F       22C/71F

Shutdown temperature source is 'hotpoint' on CI(6),
requested CI(6)

+12V measured at 12.12
+5V measured at 5.13
-12V measured at -11.84
+24V measured at 24.06
+2.5 reference is 2.49
```

Checking the Installation

```
RSP7010#sho env all
Arbiter type 1, backplane type 70x0 (id 5)
Power supply #1 is 600W AC (id 1)
Active fault conditions: none
Active trip points: none

                                01234
Dbus slots:  X X

card      inlet      hotpoint      exhaust
CI(4)    22C/71F    34C/93F      24C/75F

Shutdown temperature source is 'hotpoint' on CI(4),
requested CI(4)

+12V measured at 12.31
+5V measured at 5.17
-12V measured at -11.89
+24V measured at 23.78
+2.5 reference is 2.49
```

If after several attempts, the RSP7000CI does not appear to be functioning properly, or if you experience trouble with the installation (for instance, if the holes in the board do not align with the backplane holes), contact a service representative or the Technical Assistance Center (TAC). (For the TAC phone number and email address, refer to the note at the end of this document.)

This completes the RSP7000CI replacement in the Cisco 7000 series router.

Cisco Information Online

Cisco Information Online (CIO), formerly Cisco Information Online (CIO), is Cisco Systems' primary, real-time support channel. Maintenance customers and partners can self-register on CIO to obtain additional content and services.

Available 24 hours a day, 7 days a week, CIO provides a wealth of standard and value-added services to Cisco's customers and business partners. CIO services include product information, software updates, release notes, technical tips, the Bug Navigator, configuration notes, brochures, descriptions of service offerings, and download access to public and authorized files.

CIO serves a wide variety of users through two interfaces that are updated and enhanced simultaneously—a character-based version and a multimedia version that resides on the World Wide Web (WWW). The character-based CIO (called "CIO Classic") supports Zmodem, Kermit, Xmodem, FTP, Internet e-mail, and fax download options, and is excellent for quick access to information over lower bandwidths. The WWW version of CIO provides richly formatted documents with photographs, figures, graphics, and video, as well as hyperlinks to related information.

You can access CIO in the following ways:

- WWW: <http://www.cisco.com>
- Telnet: [cio.cisco.com](telnet://cio.cisco.com)
- Modem: From North America, 408 526-8070; from Europe, 33 1 64 46 40 82. Use the following terminal settings: VT100 emulation; data bits: 8; parity: none; stop bits: 1; and baud rates up to 14.4 kbps.

For a copy of CIO's Frequently Asked Questions (FAQ), contact cio-help@cisco.com. For additional information, contact cio-team@cisco.com.

Note If you are a network administrator and need personal technical assistance with a Cisco product that is under warranty or covered by a maintenance contract, contact Cisco's Technical Assistance Center (TAC) at 800 553-2447, 408 526-7209, or tac@cisco.com. To obtain general information about Cisco Systems, Cisco products, or upgrades, contact 800 553-6387, 408 526-7208, or cs-rep@cisco.com.

This document is to be used in conjunction with the *Cisco 7000 Hardware Installation and Maintenance* or *Cisco 7010 Hardware Installation and Maintenance* publications. (25627ci.fm)

AtmDirector, Catalyst, CD-PAC, CiscoFusion, Cisco IOS, the Cisco IOS logo, CiscoPro, Cisco Systems, CiscoView, CiscoVision, CiscoWorks, ClickStart, ControlStream, EtherChannel, HubSwitch, LAN²LAN Enterprise, LAN²LAN Remote Office, LightSwitch, Newport Systems Solutions, *Packet*, Point and Click Internetworking, RouteStream, SMARTnet, StreamView, SwitchBank, SwitchProbe, SwitchVision, SynchroniCD, *The Cell*, TokenSwitch, TrafficDirector, VirtualStream, VlanDirector, WNIC, Workgroup Director, Workgroup Stack, and XCI are trademarks, Access by Cisco and Bringing the power of internetworking to everyone are service marks, and Cisco, the Cisco Systems logo, EtherSwitch, IGRP, Kalpana, the Kalpana logo, LightStream, and UniverCD are registered trademarks of Cisco Systems, Inc. All other trademarks, service marks, registered trademarks, or registered service marks mentioned in this document are the property of their respective owners.

Copyright © 1996, Cisco Systems, Inc.
All rights reserved. Printed in USA
9511R

