



Cisco SS7 Interconnect for Voice Gateways Solution Overview

Corporate Headquarters

Cisco Systems, Inc.
170 West Tasman Drive
San Jose, CA 95134-1706
USA
<http://www.cisco.com>
Tel: 408 526-4000
800 553-NETS (6387)
Fax: 408 526-4100

Customer Order Number:
Text Part Number: 78-10319-01

THE SPECIFICATIONS AND INFORMATION REGARDING THE PRODUCTS IN THIS MANUAL ARE SUBJECT TO CHANGE WITHOUT NOTICE. ALL STATEMENTS, INFORMATION, AND RECOMMENDATIONS IN THIS MANUAL ARE BELIEVED TO BE ACCURATE BUT ARE PRESENTED WITHOUT WARRANTY OF ANY KIND, EXPRESS OR IMPLIED. USERS MUST TAKE FULL RESPONSIBILITY FOR THEIR APPLICATION OF ANY PRODUCTS.

THE SOFTWARE LICENSE AND LIMITED WARRANTY FOR THE ACCOMPANYING PRODUCT ARE SET FORTH IN THE INFORMATION PACKET THAT SHIPPED WITH THE PRODUCT AND ARE INCORPORATED HEREIN BY THIS REFERENCE. IF YOU ARE UNABLE TO LOCATE THE SOFTWARE LICENSE OR LIMITED WARRANTY, CONTACT YOUR CISCO REPRESENTATIVE FOR A COPY.

The Cisco implementation of TCP header compression is an adaptation of a program developed by the University of California, Berkeley (UCB) as part of UCB's public domain version of the UNIX operating system. All rights reserved. Copyright © 1981, Regents of the University of California.

NOTWITHSTANDING ANY OTHER WARRANTY HEREIN, ALL DOCUMENT FILES AND SOFTWARE OF THESE SUPPLIERS ARE PROVIDED "AS IS" WITH ALL FAULTS. CISCO AND THE ABOVE-NAMED SUPPLIERS DISCLAIM ALL WARRANTIES, EXPRESSED OR IMPLIED, INCLUDING, WITHOUT LIMITATION, THOSE OF MERCHANTABILITY, FITNESS FOR A PARTICULAR PURPOSE AND NONINFRINGEMENT OR ARISING FROM A COURSE OF DEALING, USAGE, OR TRADE PRACTICE.

IN NO EVENT SHALL CISCO OR ITS SUPPLIERS BE LIABLE FOR ANY INDIRECT, SPECIAL, CONSEQUENTIAL, OR INCIDENTAL DAMAGES, INCLUDING, WITHOUT LIMITATION, LOST PROFITS OR LOSS OR DAMAGE TO DATA ARISING OUT OF THE USE OR INABILITY TO USE THIS MANUAL, EVEN IF CISCO OR ITS SUPPLIERS HAVE BEEN ADVISED OF THE POSSIBILITY OF SUCH DAMAGES.

Access Registrar, AccessPath, Any to Any, AtmDirector, Browse with Me, CCDA, CCDE, CCDP, CCIE, CCNA, CCNP, CCSI, CD-PAC, the Cisco logo, Cisco Certified Internetwork Expert logo, *CiscoLink*, the Cisco Management Connection logo, the Cisco NetWorks logo, the Cisco Powered Network logo, Cisco Systems Capital, the Cisco Systems Capital logo, Cisco Systems Networking Academy, the Cisco Systems Networking Academy logo, the Cisco Technologies logo, ConnectWay, Fast Step, FireRunner, Follow Me Browsing, FormShare, GigaStack, IGX, Intelligence in the Optical Core, Internet Quotient, IP/VC, Kernel Proxy, MGX, Natural Network Viewer, NetSonar, Network Registrar, the Networkers logo, *Packet*, PIX, Point and Click Internetworking, Policy Builder, Precept, RateMUX, ScriptShare, Secure Script, ServiceWay, Shop with Me, SlideCast, SMARTnet, SVX, *The Cell*, TrafficDirector, TransPath, ViewRunner, Virtual Loop Carrier System, Virtual Voice Line, VlanDirector, Voice LAN, Wavelength Router, Workgroup Director, and Workgroup Stack are trademarks; Changing the Way We Work, Live, Play, and Learn, Empowering the Internet Generation, The Internet Economy, and The New Internet Economy are service marks; and Aironet, ASIST, BPX, Catalyst, Cisco, Cisco IOS, the Cisco IOS logo, Cisco Systems, the Cisco Systems logo, the Cisco Systems Cisco Press logo, Enterprise/Solver, EtherChannel, EtherSwitch, FastHub, FastLink, FastPAD, FastSwitch, GeoTel, IOS, IP/TV, IPX, LightStream, LightSwitch, MICA, NetRanger, Post-Routing, Pre-Routing, Registrar, StrataView Plus, Stratm, TeleRouter, and VCO are registered trademarks of Cisco Systems, Inc. or its affiliates in the U.S. and certain other countries. All other trademarks mentioned in this document are the property of their respective owners. The use of the word partner does not imply a partnership relationship between Cisco and any of its resellers. (0004R)

Cisco SS7 Interconnect for Voice Gateways Solution Overview
Copyright © 2000, Cisco Systems, Inc.
All rights reserved.



Preface vii

| | |
|--|------|
| Document Objectives | vii |
| Audience | vii |
| Document Organization | viii |
| Cisco SS7 Interconnect for Voice Gateways Solution Documentation Map | viii |
| Cisco SS7 Interconnect for Voice Gateways Solution Documentation Suite | x |
| Document Conventions | x |
| Obtaining Documentation | xi |
| World Wide Web | xi |
| Documentation CD-ROM | xi |
| Ordering Documentation | xii |
| Obtaining Technical Assistance | xii |
| Cisco Connection Online | xii |
| Technical Assistance Center | xiii |
| Documentation Feedback | xiii |

CHAPTER 1

Cisco SS7 Interconnect for Voice Gateways Solution Introduction 1-1

| | |
|---|------|
| Cisco Signaling Controller Product Information | 1-2 |
| Architecture | 1-2 |
| Understanding Terminology | 1-4 |
| Benefits | 1-4 |
| Features | 1-4 |
| Scalability and Performance | 1-6 |
| System Redundancy | 1-6 |
| Signaling Controller Management | 1-7 |
| Access Gateway Management | 1-8 |
| Cisco Signaling Link Terminal Management | 1-9 |
| Cisco SS7 Interconnect for Voice Gateways Solution Applications | 1-10 |
| Two-Stage-Dial Toll Bypass | 1-10 |
| PSTN Voice and Fax Traffic Offload | 1-11 |
| Packet Telephony and Data Wholesale Services | 1-11 |

CHAPTER 2

Cisco SS7 Interconnect for Voice Gateways Solution Configuration Options and Components 2-1

- Cisco SS7 Interconnect for Voice Gateways Solution Configurations 2-1
 - Simplex and Redundancy Options 2-1
 - Signaling Network Connection Options 2-3
 - Control Signaling Network Options 2-5
- Cisco SS7 Interconnect for Voice Gateways Solution Components 2-7
 - SC Node Products 2-8
 - Access Gateways 2-11
 - LAN Switches (Optional) 2-12

CHAPTER 3

Cisco SS7 Interconnect for Voice Gateways Solution Operations 3-1

- Unattended Operation 3-1
 - Understanding System Redundancy 3-1
 - Understanding Automatic Switchover 3-2
 - System Messages 3-2
 - Call Detail Recording (CDR) 3-3
 - Disk Mirroring 3-3
- Manual Control Options 3-4

CHAPTER 4

Cisco SS7 Interconnect for Voice Gateways Solution Implementation 4-1

- Implementation Task List 4-1
- Hardware Installation 4-2
 - Signaling Controller Installation 4-3
 - Cisco SLT Installation 4-3
 - Network Access Installation 4-4
- Signaling Controller Software Installation 4-5
- Signaling Controller Software Configuration 4-5
 - Configuring the Signaling Controller 4-6
 - Configuring the Cisco SLT 4-8
 - Configuring the LAN Switch (Optional) 4-9
- Access Gateway Installation and Configuration 4-10
- Gatekeeper Installation and Configuration (Optional) 4-11
- Operation and Maintenance 4-11
- Configuring Other Components 4-12
- Getting Help 4-12

| | |
|---|------|
| Where to Get the Latest Version of This Guide | 4-13 |
| Hotlinks to Online Documentation | 4-13 |
| If You Need More Information | 4-14 |
| Cisco Connection Online | 4-15 |

APPENDIX A**SS7 Technology Overview A-1**

| | |
|-------------------------|-----|
| SS7 Technology Overview | A-1 |
| Point Codes | A-2 |
| Reference Documentation | A-4 |

APPENDIX B**Voice over IP Overview B-1**

| | |
|-------------------------------------|-----|
| Voice over IP Overview | B-1 |
| How VoIP Processes a Telephone Call | B-2 |
| Key Elements | B-3 |
| Reference Documentation | B-5 |

INDEX



Preface

This section describes the objectives, audience, organization, and conventions of the Cisco SS7 Interconnect for Voice Gateways Solution. This document points to related publications and describes online sources of technical information.

Document Objectives

The Cisco SS7 Interconnect for Voice Gateways Solution provides SS7 connectivity for voice gateways by using the Cisco signaling controller as a protocol translator to control the gateway through the ISDN Q.931 protocol.

This guide is designed to provide you with an overview of the Cisco SS7 Interconnect for Voice Gateways Solution and brief information about its components. It describes initial site preparation and implementation information with pointers to detailed hardware installation and software configuration documentation.

Audience

This document is part of a suite of documents for the following users. See the “Cisco SS7 Interconnect for Voice Gateways Solution Documentation Suite” section.

- Component installers—Who have experience installing telecommunications equipment and cables, as well as experience installing data communications equipment and cabling.
- Network operators/administrators—Who have experience in telecommunications networks, protocols, and equipment, as well as a familiarity with data communications networks, protocols, and equipment.
- Network designers—Who have experience with telecommunications networks, protocols, and equipment, as well as experience with data communications networks, protocols, and equipment.

Document Organization

The major sections of this document are as follows:

Chapters

| | | |
|------------|---|--|
| Chapter 1 | Cisco SS7 Interconnect for Voice Gateways Solution Introduction | Provides an introduction to the Cisco SS7 Interconnect for Voice Gateways Solution, describes architecture, benefits, features, and applications. |
| Chapter 2 | Cisco SS7 Interconnect for Voice Gateways Solution Configuration Options and Components | Provides information about configuration options and brief description of components. |
| Chapter 3 | Cisco SS7 Interconnect for Voice Gateways Solution Operations | Describes unattended operations and manual control options. |
| Chapter 4 | Cisco SS7 Interconnect for Voice Gateways Solution Implementation | Provides sequence of implementation steps for the hardware connections and for installing software. Also, provides high-level component configuration steps with pointers to detailed documents. |
| Appendix A | SS7 Technology Overview | Provides a brief overview of the SS7 technology used in this guide. |
| Appendix B | Voice over IP Overview | Provides a brief overview of the VoIP technology used in this guide. |

Cisco SS7 Interconnect for Voice Gateways Solution Documentation Map

Refer to the following documentation map to navigate through the Cisco SS7 Interconnect for Voice Gateways Solution documentation suite.

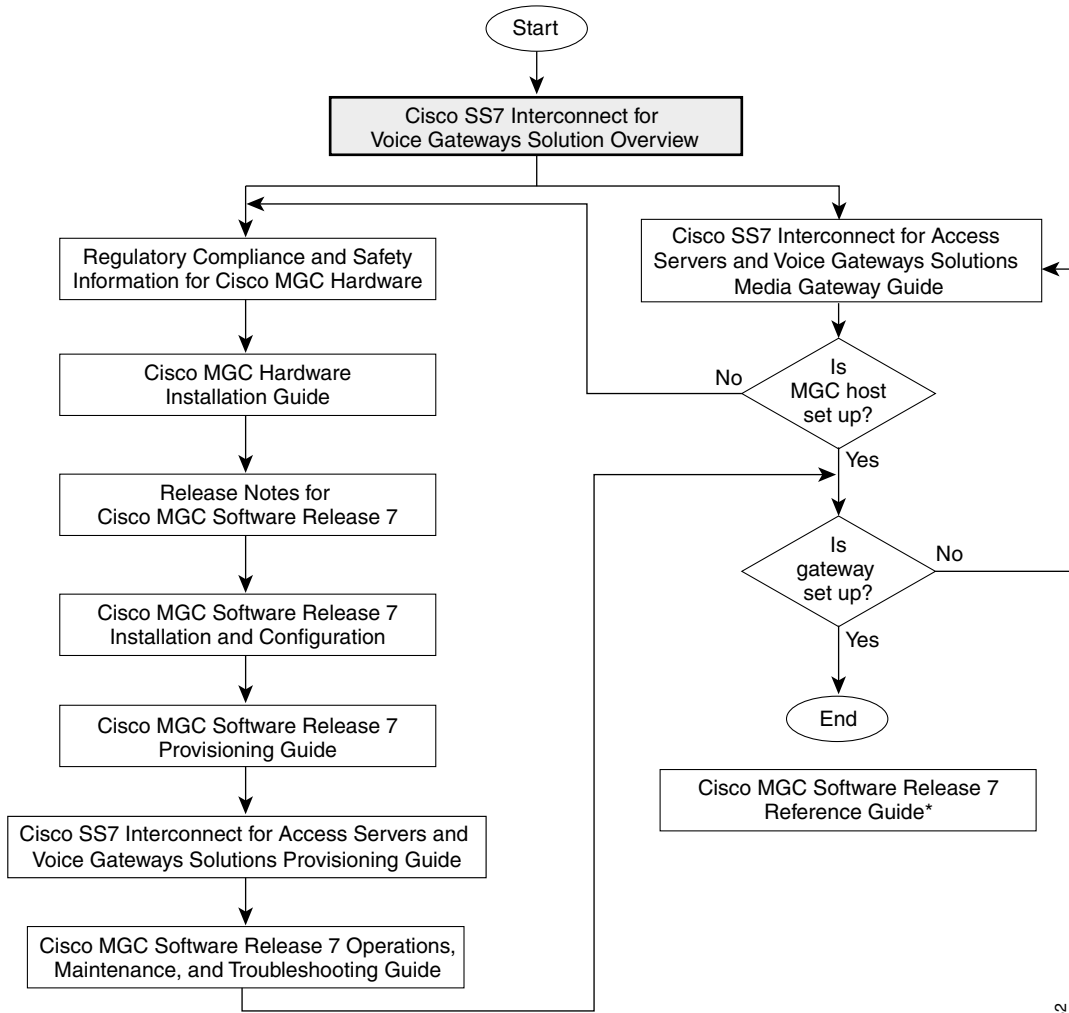

* This guide provides useful information that is not required during installation.

306832

Cisco SS7 Interconnect for Voice Gateways Solution Documentation Suite

Refer to the following documents for detailed hardware and software installation and configuration information about the Cisco SS7 Interconnect for Voice Gateways Solution:

- *Cisco SS7 Interconnect for Access Servers and Voice Gateways Solutions Provisioning Guide*
- *Cisco SS7 Interconnect for Access Servers and Voice Gateways Solutions Media Gateway Guide*
- *Cisco Media Gateway Controller Hardware Installation Guide*
- *Regulatory Compliance and Safety Information for Cisco Media Gateway Controller Hardware*
- *Cisco Media Gateway Controller Software Release 7 Installation and Configuration Guide*
- *Cisco Media Gateway Controller Software Release 7 Provisioning Guide*
- *Cisco Media Gateway Controller Software Release 7 Reference Guide*
- *Cisco Media Gateway Controller Software Release 7 Operations, Maintenance, and Troubleshooting Guide*
- Release Notes for Cisco Media Gateway Controller Software Release 7

Refer to the following documents for detailed Cisco IOS documentation about the Cisco SS7 Interconnect for Voice Gateways Solution:

- Cisco IOS 12.0(7)XR release notes
- Cisco IOS Release 12.0(7)XR, *Cisco H.323 VoIP with SS7 for the Cisco AS5300*

Document Conventions

Command descriptions use the following conventions:

| | |
|----------------------|---|
| boldface font | Commands and keywords are in boldface . |
| <i>italic font</i> | Arguments for which you supply values are in <i>italics</i> . |
| [] | Elements in square brackets are optional. |
| { x y z } | Alternative keywords are grouped in braces and separated by vertical bars. |
| [x y z] | Optional alternative keywords are grouped in brackets and separated by vertical bars. |
| string | A nonquoted set of characters. Do not use quotation marks around the string or the string will include the quotation marks. |

Screen examples use the following conventions:

| | |
|-----------------------------------|---|
| <code>screen font</code> | Terminal sessions and information the system displays are in <code>screen font</code> . |
| <code>boldface screen font</code> | Information you must enter is in <code>boldface screen font</code> . |
| <i>italic screen font</i> | Arguments for which you supply values are in <i>italic screen font</i> . |
| → | This pointer highlights an important line of text in an example. |
| ^ | The symbol ^ represents the key labeled Control. For example, the key combination ^D in a screen display means hold down the Control key while you press the D key. |
| < > | Nonprinting characters, such as passwords, are in angle brackets. |
| [] | Default responses to system prompts are in square brackets. |
| !, # | An exclamation point (!) or a pound sign (#) at the beginning of a line of code indicates a comment line. |

Notes use the following conventions:



Note

Means *reader take note*. Notes contain helpful suggestions or references to material not covered in the publication.

Cautions use the following conventions:



Caution

Means *reader be careful*. In this situation, you might do something that could result in equipment damage or loss of data.

Obtaining Documentation

World Wide Web

You can access the most current Cisco documentation on the World Wide Web at <http://www.cisco.com>, <http://www-china.cisco.com>, or <http://www-europe.cisco.com>.

Documentation CD-ROM

Cisco documentation and additional literature are available in a CD-ROM package, which ships with your product. The Documentation CD-ROM is updated monthly. Therefore, it is probably more current than printed documentation. The CD-ROM package is available as a single unit or as an annual subscription.

Ordering Documentation

Registered CCO users can order the Documentation CD-ROM and other Cisco Product documentation through our online Subscription Services at <http://www.cisco.com/cgi-bin/subcat/kaojump.cgi>.

Nonregistered CCO users can order documentation through a local account representative by calling Cisco's corporate headquarters (California, USA) at 408 526-4000 or, in North America, call 800 553-NETS (6387).

Obtaining Technical Assistance

Cisco provides Cisco Connection Online (CCO) as a starting point for all technical assistance. Warranty or maintenance contract customers can use the Technical Assistance Center. All customers can submit technical feedback on Cisco documentation using the web, e-mail, a self-addressed stamped response card included in many printed docs, or by sending mail to Cisco.

Cisco Connection Online

Cisco continues to revolutionize how business is done on the Internet. Cisco Connection Online is the foundation of a suite of interactive, networked services that provides immediate, open access to Cisco information and resources at anytime, from anywhere in the world. This highly integrated Internet application is a powerful, easy-to-use tool for doing business with Cisco.

CCO's broad range of features and services helps customers and partners to streamline business processes and improve productivity. Through CCO, you will find information about Cisco and our networking solutions, services, and programs. In addition, you can resolve technical issues with online support services, download and test software packages, and order Cisco learning materials and merchandise. Valuable online skill assessment, training, and certification programs are also available.

Customers and partners can self-register on CCO to obtain additional personalized information and services. Registered users may order products, check on the status of an order and view benefits specific to their relationships with Cisco.

You can access CCO in the following ways:

- WWW: www.cisco.com
- Telnet: [cco.cisco.com](telnet://cco.cisco.com)
- Modem using standard connection rates and the following terminal settings: VT100 emulation; 8 data bits; no parity; and 1 stop bit.
 - From North America, call 408 526-8070
 - From Europe, call 33 1 64 46 40 82

You can e-mail questions about using CCO to cco-team@cisco.com.

Technical Assistance Center

The Cisco Technical Assistance Center (TAC) is available to warranty or maintenance contract customers who need technical assistance with a Cisco product that is under warranty or covered by a maintenance contract.

To display the TAC web site that includes links to technical support information and software upgrades and for requesting TAC support, use www.cisco.com/techsupport.

To contact by e-mail, use one of the following:

| Language | E-mail Address |
|------------------|--|
| English | tac@cisco.com |
| Hanzi (Chinese) | chinese-tac@cisco.com |
| Kanji (Japanese) | japan-tac@cisco.com |
| Hangul (Korean) | korea-tac@cisco.com |
| Spanish | tac@cisco.com |
| Thai | thai-tac@cisco.com |

In North America, TAC can be reached at 800 553-2447 or 408 526-7209. For other telephone numbers and TAC e-mail addresses worldwide, consult the following web site:
<http://www.cisco.com/warp/public/687/Directory/DirTAC.shtml>.

Documentation Feedback

If you are reading Cisco product documentation on the World Wide Web, you can submit technical comments electronically. Click **Feedback** in the toolbar and select **Documentation**. After you complete the form, click **Submit** to send it to Cisco.

You can e-mail your comments to bug-doc@cisco.com.

To submit your comments by mail, for your convenience many documents contain a response card behind the front cover. Otherwise, you can mail your comments to the following address:

Cisco Systems, Inc.
Document Resource Connection
170 West Tasman Drive
San Jose, CA 95134-9883

We appreciate and value your comments.



Cisco SS7 Interconnect for Voice Gateways Solution Introduction

When you make calls using your telephone or PC terminal and modem, you generally use the Public Switched Telephone Network (PSTN). You hear progress tones such as a dial tone or a busy tone that tell you your call is being processed. These are alerting tones that are produced by the PSTN. Alerting tones are used to communicate from the PSTN to users, and telecommunications computers, or “switches,” communicate with each other through standards-based signaling. Signaling is the backbone for interconnection between carrier, cellular, and wireless networks. Signals are the medium that set up and tear down your calls.

A major breakthrough in signaling networks was to separate the signaling path from voice and data conversation. This is called “common channel interoffice signaling (CCS).” CCS, also known as out-of-band signaling, is a data network that overlays a carrier’s switching network. Using CCS increases network intelligence, efficiency, automation, and functionality. CCS has evolved into a standard called Signaling System 7 (SS7), a protocol that lowered costs and increased network reliability even further. With SS7, all carriers are able to interoperate as a consistent and seamless network. Services such as global billing, wireless roaming, and 800 number calling rely on the SS7 protocol to exchange messages reliably.

The Cisco SS7 Interconnect for Voice Gateways Solution is a distributed system that provides SS7 connectivity for VoIP access gateways by using the Cisco Signaling Controller (also referred to as the Cisco SC2200 product) and the access gateways as a bridge from the H.323 IP network to the PSTN network. This solution interacts over the IP network with other Cisco H.323 VoIP access gateways. In addition, the Cisco SS7 Interconnect for Voice Gateways Solution can interoperate with H.323 endpoints, using non-SS7 signaling such as ISDN PRI and channelized T1.

Figure 1-1 illustrates where the Cisco SS7 Interconnect for Voice Gateways Solution is located when it is dropped into a PSTN to offload calls. By placing the solution as close to the ingress switch as possible, voice and data traffic ties up fewer PSTN resources. The direct connection of the Cisco SS7 Interconnect for Voice Gateways Solution to the SS7 network provides advantages such as faster call setups and teardowns, as well as SS7’s look-ahead capabilities for rerouting to avoid downed network nodes and links.

Figure 1-1 With a Cisco SS7 Interconnect for Voice Gateways Solution

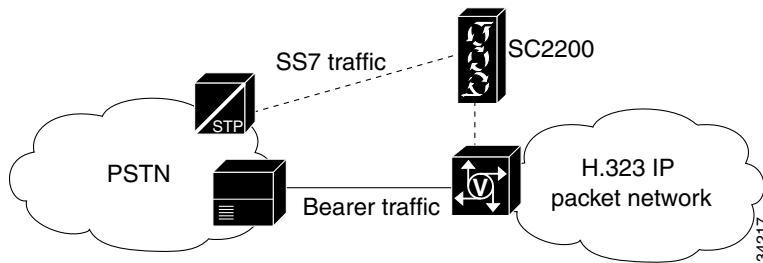

Cisco Signaling Controller Product Information

The Cisco signaling controller (Cisco SC2200) product is an application supported by the Cisco media gateway controller (Cisco MGC) product line that addresses the scalability of ISP dial modem traffic. The MGC is a powerful call control application that can be used to facilitate a wide variety of telecommunication services using data infrastructures. This new world architecture allows end users to realize the benefits of deploying a single network to address both data and voice applications.



Note

Your Cisco SS7 Interconnect for Voice Gateways Solution documentation suite includes media gateway controller (MGC) reference books.



Note

Some product labels and packaging might use the term telephony controller. Any references to the telephony controller apply to the media gateway controller (MGC).

Architecture

The Cisco SS7 Interconnect for Voice Gateways Solution architecture provides SS7 connectivity for voice gateways, by way of the SC host as a protocol translator, using ISDN Q.931 and SS7 as control protocols.

The solution consists of the following required components that are described in more detail in the “Cisco SS7 Interconnect for Voice Gateways Solution Components” section of this document:

| | |
|--|---|
| Cisco Signaling Controller Host (Cisco SC2200) | Operates as an SS7 to ISDN protocol converter front-end to the Cisco access gateways. |
| Cisco Signaling Link Terminal (Cisco SLT) | Used for physical SS7 link termination. |
| Cisco Access Gateway (Cisco AS5300) | Used for bearer channel termination. |



| | |
|--|--|
| <p>Gatekeeper (Cisco 3640)</p> | <p>Manages other nodes in an H.323 network. (Optional)</p> <p> Note This solution uses the Cisco 3640 gatekeeper, but supports any H.323 compliant gatekeeper used in your IP network.</p> |
| <p>LAN Switch (Cisco Catalyst Switch Family)</p> | <p>A switch to extend VLANs across platforms through backbone Fast Ethernet, Gigabit, or ATM connections, when necessary. Connects multiple Cisco SLTs to the active and standby hosts within the SC node. Connects the Network Access Servers with their controlling SC node. Connects the originating SC zone to the terminating SC node between SC zones.</p> <p> Note The switch is customer premise equipment and is not provided with the Cisco signaling controller.</p> |

Figure 1-2 Cisco SS7 Interconnect for Voice Gateways Solution Architecture



Understanding Terminology

The key terms used to describe the Cisco SS7 Interconnect for Voice Gateways Solution architecture are:

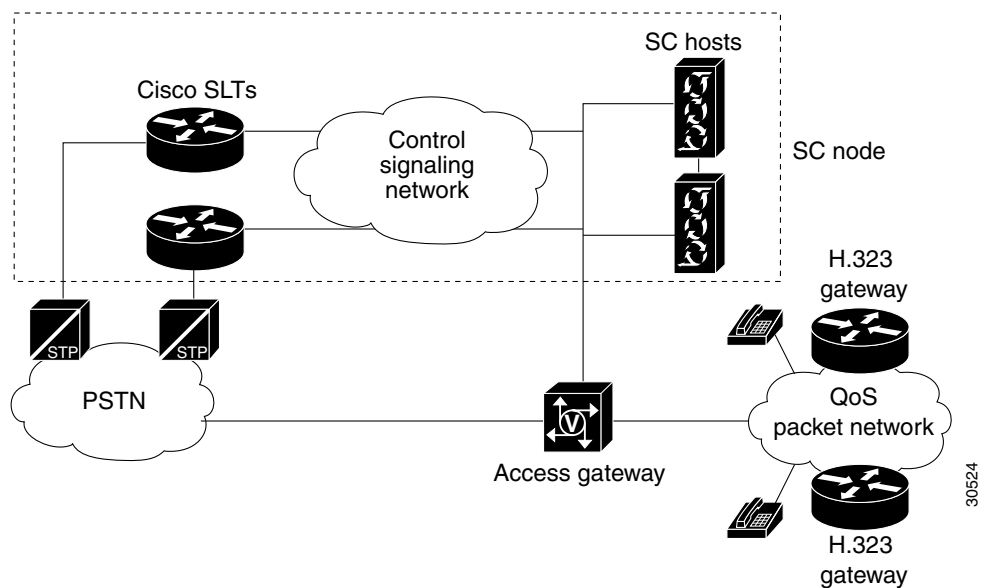
- Cisco SC2200—A hardware and software package that provides the signaling controller function. Typically this includes two SC hosts configured in a redundant manner for increased availability.
- SC host—A Sun host running signaling controller software.
- SC node—The combination of hardware (Sun servers and Cisco SLTs) and software that provides the signaling controller function and transports the signaling traffic between the SC hosts and the SS7 signaling network.
- SC zone—The combination of an SC node and the Cisco access gateways that are provided with signaling services.

Benefits

Using the Cisco SS7 Interconnect for Voice Gateways Solution provides the following benefits:

- Provides wholesale dial services, dial-up VPNs, Internet access, and voice services, while interconnecting as a carrier.
- Addresses voice network congestion by using the SS7 interfaces to make features such as rerouting on overflow conditions and the use of IN functions possible, which further drives down operating costs.
- Replaces ISDN PRIs with bearer trunks and increase available bandwidth.
- Installs an SS7 POP in a new location without the added expense of a switch.
- Integrates the access gateways directly into the SS7 network, using the Cisco SS7 Interconnect for Voice Gateways Solution, and thus remove the need for two switch ports on the PSTN circuit switch for each NAS port installed.
- Increases the signaling channel to bearer channel ratios, thus decreasing the number of signaling channels needed and the overall complexity of the system or network.
- Provides economical reliability of SS7 link termination by using channelized E1/T1 software on the Cisco SLT.
- Transparently passes individual and uncompressed T1 or E1 channels between T1 or E1 ports by using Drop and Insert interfaces.

Features

Table 1-1 briefly lists features that are provided with your Cisco SS7 Interconnect for Voice Gateways Solution. For an overview of scalability and performance, system redundancy, management, and software requirements, see subsequent sections of this document.

Table 1-1 Features for the Cisco SS7 Interconnect for Voice Gateways Solution

| Feature | Purpose |
|--|---|
| Directly connects access gateways to PSTN in a peer-to-peer interconnect | <ul style="list-style-type: none"> • Reduces network costs • Interconnects with more favorable tariffs and rates |
| Supports Cisco H.323 access gateways and gatekeepers | Provides SS7 connectivity for intelligent H.323 endpoints: <ul style="list-style-type: none"> • Offers long-distance and international low-rate telephony services • Uses packet telephony technology for cost-effective offloading of voice traffic from congested PSTN networks |
| Supports co-located and distributed access gateways | <ul style="list-style-type: none"> • Cost savings; scalable and flexible |
| Terminates and originates switching-system functions | <ul style="list-style-type: none"> • Enables new services • Fast time to market • Dial-out and dial-in • Meets interconnect requirements |
| Worldwide protocol support using Cisco Message Definition Language (MDL). | <ul style="list-style-type: none"> • Is certified worldwide • Fast time to market |
| Provides software upgrade of: <ul style="list-style-type: none"> • Cisco IOS • Signaling controller and Sun OS software • Cisco Signaling Link Terminal | <ul style="list-style-type: none"> • Protects Cisco investments • Provides low cost of ownership • Is part of a complete solution with Cisco IOS software |
| Provides a reliable IP link between signaling controllers and access gateways with Redundant Link Manager (RLM) | No single point of failure in connection between access gateways and signaling controllers |
| <ul style="list-style-type: none"> • Radius or TACACS+ AAA functions, including authentication based on calling or called number • Provides call detail records for PSTN billing • Radius Proxy (GRS) | Meet PSTN requirements to create new service opportunities |
| Provides facility associated signaling through the Cisco SLTs | <ul style="list-style-type: none"> • Grooms the bearer channels and then delivers, or hairpins, them to the access gateway • Backhauls MTP-3 to the signaling controller over RUDP/IP |
| Fault-tolerant platform | <ul style="list-style-type: none"> • Provides no more than 6 seconds of downtime per year |
| Continuous service platform | <ul style="list-style-type: none"> • Established calls are maintained upon failover |

Table 1-1 Features for the Cisco SS7 Interconnect for Voice Gateways Solution (continued)

| Feature | Purpose |
|-------------------------|--|
| Sun OS 2.6.1 | <ul style="list-style-type: none"> • Y2K compliant • Open computing platform |
| Cisco MGC Manager (CMM) | <ul style="list-style-type: none"> • Full SNMP configuration |

Scalability and Performance

The Table 1-2 lists the scalability and performance of the Cisco SS7 Interconnect for Voice Gateways Solution.

Table 1-2 Scalability and Performance of the Cisco SS7 Interconnect for Voice Gateways Solution

| Feature | Benefit |
|--|--|
| <ul style="list-style-type: none"> • Scaling up to 50,000 DS-0 ports • As many as 50 calls per second throughput • 180,000 busy hour call attempts | <ul style="list-style-type: none"> • Scale cost-effectively to central-office size |
| <ul style="list-style-type: none"> • Support for 250+ destination point codes (DPCs) • Support for 6 originating point codes (OPCs) • Quasi-associated or fully associated signaling • Complete continuity check (two-wire and four-wire) • NEBS Level 3 compliant • Three signaling controller platform options | <ul style="list-style-type: none"> • Flexible and scalable • Ready for international markets • Meets interconnect requirements • Telco ready • Cost-effective options |

System Redundancy

For maximum reliability and resilience, we recommend the following options:

- Deploying the Cisco SS7 Interconnect for Voice Gateways Solution continuous service configuration at your site. The continuous service configuration consists of an active server and a standby server, linked by a heartbeat function. Also, all configuration changes made to the active server are replicated on the standby server.
- Using a minimum of two LAN switches from the Cisco Catalyst switch family that support
 - ISL trunking protocol configured between the two switches.
 - One route-switch module (RSM), which routes traffic between the VLANs when necessary.
- Using a minimum of two links per linkset if signaling links are connected to the Cisco signaling controllers. The links should be split across separate T1/E1 interface cards on the LAN switches, SC hosts, and Cisco SLTs.

Signaling Controller Management

Table 1-3 provides an overview of the management components of the signaling controller.

Table 1-3 Management Components of the Signaling Controller

| Management Component | Description |
|--------------------------|---|
| Configuration Management | <p>The Cisco MGC Manager (CMM) is a graphical user interface (GUI) that uses SNMP to configure and provision your solution network. You can access the CCM remotely, using Xterminals, and manage all the TCHOSTs in your network with a single CMM system.</p> <p>Dial Provisioning Plan (DPP) is used to format the dial plan and routing data for deployment on the signaling controller. Dial plan and routing data is defined in a flat file, and this information is parsed by the DPP to generate the configuration files for deployment on the signaling controller.</p> |
| Fault Management | <p>The signaling controller supports a comprehensive set of alarms:</p> <ul style="list-style-type: none"> • Configuration • Resource • Operating system • I/O card • Signaling channel failure • Line interface loss of signal <p>You can customize the severity of alarm and thresholds to match your carrier's severity level definitions. You can also configure the system to generate real-time alarms to local or remote terminals. All alarms are written to a log file in an uncompressed format for easy retrieval.</p> |

Table 1-3 Management Components of the Signaling Controller (continued)

| Management Component | Description |
|------------------------|--|
| Performance Management | <p>You can get a variety of usage statistics from the signaling controller. The data is recorded real-time and is written to a file. You can specify the statistics to be collected and the time intervals for collection and writing to the file. Each performance measurement record includes:</p> <ul style="list-style-type: none"> • Start time • Duration • Measured value • Category • Element measured |
| Accounting Management | <p>Every call that passes through the signaling controller produces call detail information, which includes:</p> <ul style="list-style-type: none"> • CLI pretranslated • CLI posttranslated • Dialed number pretranslated • Dialed number posttranslated • Start, seizure, supervision, and disconnect time stamps • Circuit path information <p>Call detail records are written to a spool file that is automatically closed at defined intervals or when the file exceeds a specified size. You can also specify when to retrieve or send closed files to processing systems.</p> |

Access Gateway Management

The Cisco IOS software installed on the access gateways provides an array of network management components (described in Table 1-4) designed to meet the needs of today's large, complex networks.

These management features do the following:

- Reduce network bandwidth and processing overhead
- Offload management servers
- Conserve resources
- Ease system configuration tasks

Cisco's integrated management simplifies administrative procedures and shortens the time required to diagnose and fix geographically dispersed networks with a small, centrally located staff of experts. Configuration services reduce the cost of installing, upgrading, and reconfiguring network equipment.

Table 1-4 Network Management Components

| Management component | Description |
|-----------------------------|--|
| SNMP and RMON Support | <p>Access gateways are fully manageable by using the Simple Network Management Protocol (SNMP) and imbedded Remote Monitoring (RMON) capabilities:</p> <ul style="list-style-type: none"> • SNMP provides for the collection of information about each controller and interface, which can be polled through any SNMP-compatible network management system. • RMON acts as a remote protocol analyzer and LAN probe. <p>By using the Alarm RMON group, you can set a threshold on any integer-valued Management Information Base (MIB) variable. When the threshold is crossed, an event, defined in the Event RMON group, is triggered. With these capabilities, the system can detect and analyze overloaded conditions and congestion in real time.</p> |
| Network Management Systems | <p>The access gateways both support CLI and CiscoView graphical user interface (GUI) for comprehensive, flexible network management.</p> <p>CiscoView provides dynamic status, statistics, and comprehensive configuration information for Cisco switches, routers, access gateways, Cisco SLTs, concentrators, and adapters. It displays a graphical view of Cisco devices, provides configuring and monitoring functions, and offers basic troubleshooting.</p> |
| Modem Management | <p>Cisco offers two types of modems: basic and managed. Managed modems offer superior reporting and statistics in the CiscoView application, including troubleshooting and monitoring modem connections on individual or groups of modems, while calls are in progress.</p> <p>You can manage modems using the same tools used to manage the rest of the network. In addition, managed modems provide an out-of-band management feature that allows you to reduce problem detection and resolution time from a remote site.</p> <p>Through out-of-band management, you can view real-time information (for current or previous calls) such as modem modulation scheme, modem protocol, modem EIA/TIA-232 signal states, modem transmit and receive states, and analog signal-to-noise ratio.</p> |

Cisco Signaling Link Terminal Management

The Session Manager software, running on the Cisco SLT, manages the communication sessions between two SC hosts.

The session manager:

- Maintains separate communication sessions with each signaling controller in the pair
- Uses RUDP to communicate between the Cisco SLT and the signaling controller
- In a continuous service configuration, handles additional traffic in the event of a single Cisco SLT failure, with no impact to call processing

Cisco SS7 Interconnect for Voice Gateways Solution Applications

The Cisco SS7 Interconnect for Voice Gateways Solution preserves full capabilities on the IP side, including existing H.323 access gateway functionality, interoperability with H.323 gatekeepers, two stage dialing, mixed gateway environment, and PSTN voice and fax traffic offload. This solution targets the following key applications that support phone to phone, PC to phone, and fax relay packet telephony services:

- Two-Stage-Dial Toll Bypass
- PSTN Voice and Fax Traffic Offload
- Packet Telephony and Data Wholesale Services

Settlement providers require services such as two-stage dialing, international toll bypass, and open settlements, as illustrated in Figure 1-3.

Figure 1-3 A Typical Settlement Provider Application

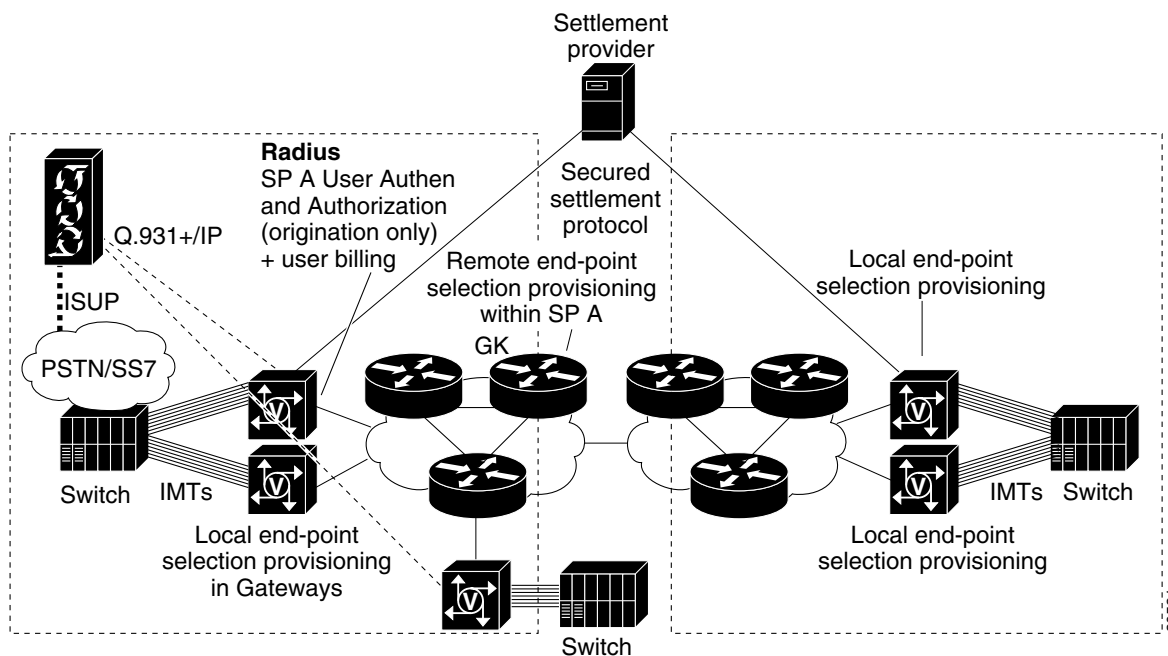

Two-Stage-Dial Toll Bypass

This application enables the service provider to leverage its WAN infrastructure and offer long-distance toll bypass services. Each customer is assigned an account number and a personal identification number (PIN). The user dials a local or a 1-800 Internet Telephony Service Provider (ITSP) number and is connected to the local VoIP point of presence.

In Figure 1-3, the first leg of the call is terminated by the access gateway (Cisco 5300) through the ISUP to Q.931+/IP translation. The user is prompted by the interactive voice response (IVR) to input account and PIN numbers, and (following an authentication by the RADIUS server) then a secondary dial tone allows the desired phone number to be entered. Also, the RADIUS authentication can be accomplished based on the combination of calling number ID (ANI) and called number (DNIS).

For fax services, the PIN number is automatically dialed by the redialer that is attached to the fax machine. An E.164 destination phone number, dialed by the user, is mapped by the local-zone gatekeeper to an IP address of a remote-zone gatekeeper. The remote-zone gatekeeper selects an access gateway to terminate the call. During the call setup, end-to-end ISUP signaling transparency is supported. After the call setup is complete, the voice is encoded by the access gateway using standard algorithms (including G.711, G.729, G.729a, and G.723.1), encapsulated in Real-Time Transport Protocol (RTP) packets, and then routed over the WAN to the remote access gateway that decodes the voice and delivers it to the receiver.

PSTN Voice and Fax Traffic Offload

This application offloads PSTN traffic from congested PSTN networks. The offloaded traffic is then forwarded to a tandem switch connected in a peer-to-peer configuration to the Cisco SS7 Interconnect for Voice Gateways Solution through access gateways. The configuration uses Direct Inward Dialing (DID) functionality, and no ANI or CDR billing is required.

Packet Telephony and Data Wholesale Services

This application enables the wholesale service provider to extend services to a specific geographical area. Again, voice and fax traffic is offloaded from PSTN onto data networks, as well as support scalable routing and QoS, across data networks, to effectively route the calls to their final destination. Routing and authorization between multiple service carriers, as well as real-time selection of a cost-effective service provider and reciprocal billing arrangements are required. Resource pooling is required for data, but not for voice.

The Open Settlement Protocol (OSP) is a communications protocol between H.323 equipment and back-end services, such as authorization, route determination, and call detail record (CDR) collection and settlement. With OSP, interdomain CDR records are forwarded to the settlement system, processed, and then transmitted as settled records to billing system platforms. The access gateways in your Cisco SS7 Interconnect for Voice Gateways Solution generate intradomain records and are accessed by any accounting and billing system based on RADIUS.



Cisco SS7 Interconnect for Voice Gateways Solution Configuration Options and Components

This chapter briefly describes the various Cisco SS7 Interconnect for Voice Gateways Solution configuration options and the required and optional components:

- Cisco SS7 Interconnect for Voice Gateways Solution Configurations
- Cisco SS7 Interconnect for Voice Gateways Solution Components

Cisco SS7 Interconnect for Voice Gateways Solution Configurations

The Cisco SS7 Interconnect for Voice Gateways Solution provides the following configuration options:

- Simplex and Redundancy Options
- Signaling Network Connection Options
- Control Signaling Network Options

Simplex and Redundancy Options

You can deploy the Cisco SS7 Interconnect for Voice Gateways Solution in one of three ways:

- Simplex Configuration
- Continuous Service Configuration

Simplex Configuration

A simplex configuration is an SC zone that consists of a single SC host (E450 or Sun Netra t 112x) operating with one or more Cisco SLTs. The SC application is run on the SC host and the SS7 signaling links are terminated on the Cisco SLT. An IP control LAN is used to interconnect the host server with the Cisco SLTs. One or more access gateways are required for bearer channel termination. See Figure 2-1.

**Note**

Simplex configurations provide no fault tolerance and are typically used for solution testing or validation or noncritical installations. If the host fails, calls are dropped, and service is discontinued.

Figure 2-1 Simplex Configuration Example

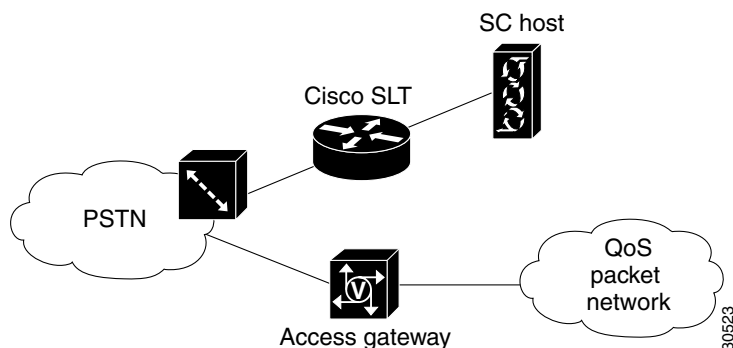

Continuous Service Configuration

A continuous service configuration is an SC zone that consists of a pair of SC hosts running in a primary (active) and secondary (standby) mode, operating with one or more access gateways and one or more Cisco SLTs. An error-checking function runs continuously between the two SC hosts, monitoring the primary SC host. When the function detects an error condition on the primary SC host, responsibility for call processing is switched to the secondary SC host. The secondary SC host now becomes the primary SC host; call preservation is maintained.

Figure 2-2 shows an example of a continuous service configuration with redundant signaling links terminating on a pair of Cisco SLTs with bearer traffic terminating on the access gateway.

Figure 2-2 Continuous Service Configuration Example

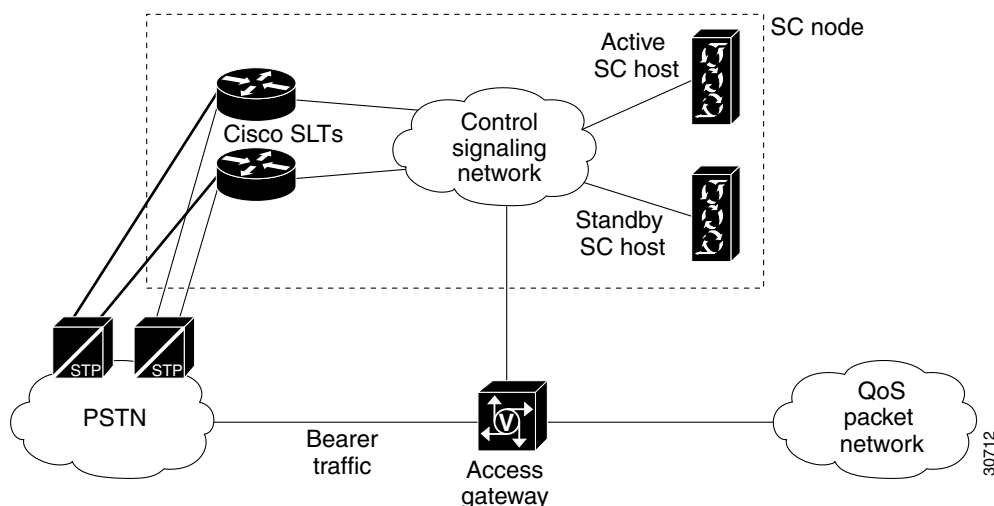

Signaling Network Connection Options

The Cisco SS7 Interconnect for Voice Gateways Solution performs functions to exchange telephone control messages between the following components that support the end user's signaling network connection:

Cisco Signaling Controller—Provides a signaling protocol conversion and network Q.931 call control to communicate with the access gateways. One signaling controller might provide signaling and call-processing services for multiple access gateways in geographically distributed locations, over redundant IP links used for ISDN signaling.

Cisco SLT—Handles the incoming and outgoing SS7 messages (MTP layer 1 and 2) from the A-links (access links) connected to Signal Transfer Points (STPs) or F-links connected to Service Switching Points (SSPs). Also, when used in Drop and Insert mode, the Cisco SLT grooms off the terminating signaling link from F-links (fully associated links) and then hairpins the bearer channels (ISUP) to the access gateway.

Cisco Access Gateway—Provides termination for PSTN trunks. An access gateway functions as a server to the SS7 bearer links. The access gateway has at least two IP network interfaces: one to carry IP packet data onto one or more of the ISP's backbones and another to connect to the ISP's secure management, signaling, and Q.931 control network.

Your Cisco SS7 Interconnect for Voice Gateways Solution can be deployed in three ways, as described in "Simplex and Redundancy Options", with the following SS7 signaling network connections.

**Note**

Type of connection would depend on your specific network requirements.

- A-Link with Cisco SLT
- F-Link with Cisco SLT
- A-Link or F-Link with Cisco SLT (Drop and Insert)

A-Link with Cisco SLT

An A-link with Cisco SLT signaling connection is an access link from the PSTN Signal Transfer Point (STP) connected to the Cisco SLT of the SC node, through RS-449, RS-530, V.35, and T1/E1 interfaces. This option can be used with simplex and continuous service host configurations. Each interface supports a single signaling channel.

In the A-link SLT signaling connection, the Cisco SLT processes the two lowest-level SS7 signaling protocols, MTP1 and MTP2. The upper layer protocols are then forwarded to the SC host over the control signaling network. Each Cisco SLT supports two signaling network connections. Multiple Cisco SLTs can be used to support additional signaling channels or provide redundant signal paths between the signaling network and the control signaling network, as illustrated in Figure 2-3.

Figure 2-3 A-Link SLT Signaling Configuration

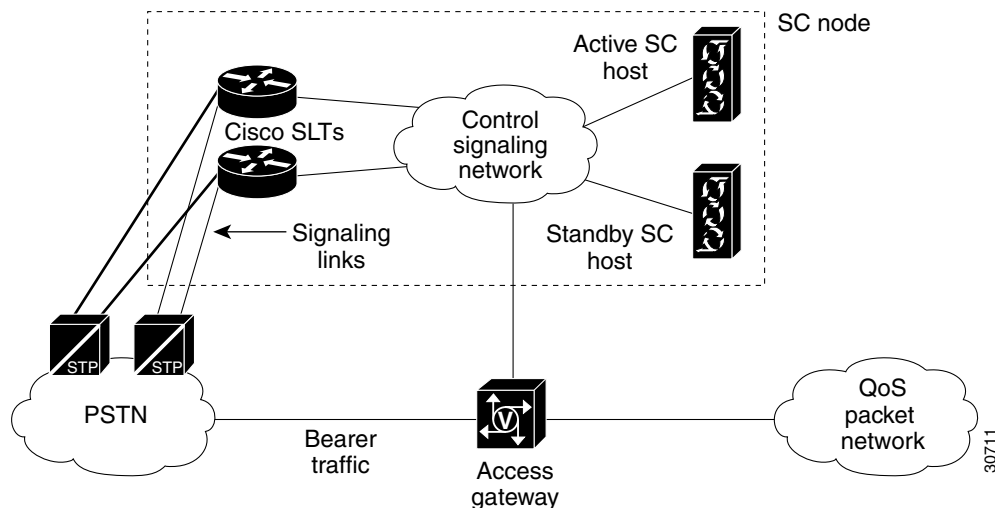

F-Link with Cisco SLT

An F-link with Cisco SLT signaling connection is a fully associated link from the SS7 network to the Cisco SLT of the SC node. F-links connect the SC host directly to a Service Switching Point (SSP) or a Service Control Point (SCP) in the SS7 network; they do not make an intermediate connection through STPs.

The F-link SLT signaling configuration supports RS-449, RS-530, V.35, and T1/E1 interfaces that are installed in the Cisco SLT. The F-link SLT configuration can be used with simplex and continuous service SC host configurations. Each interface supports a single DS0 signaling channel.

A-Link or F-Link with Cisco SLT (Drop and Insert)

An A-link or F-link with Cisco SLT (Drop and Insert) signaling connection is similar, respectively, to an A-link or F-link SLT signaling connection. Fully associated links directly connect an SSP or SCP to the Cisco SLT. The difference is that the A-link and F-link Drop and Insert configurations support a single DS0 signaling channel per link and additional bearer traffic channels up to the capacity of the T1 or E1 link as shown in Figure 2-4.



Note

The F-link Drop and Insert technique is also known as time-division multiplexing (TDM) cross-connect.

Figure 2-4 F-Link Drop and Insert Configuration

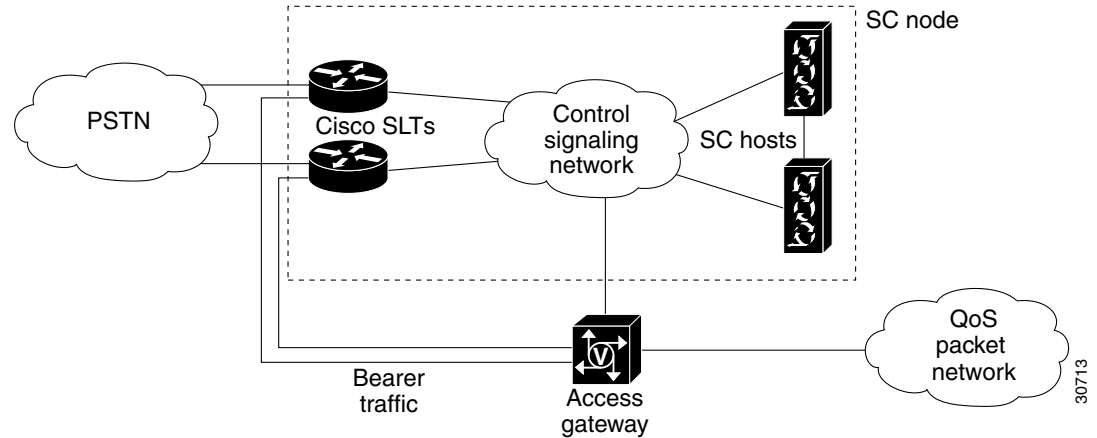

The F-link drop and insert signaling configuration supports T1 and E1 interfaces using signaling interface cards installed in the Cisco SLT. The Drop and Insert cards are special two-port cards designed for this application. Signal and bearer traffic enter one port together, then the Cisco SLT separates the bearer traffic and routes it out the second port.

The F-link Drop and Insert configuration can be used with simplex and continuous service host configurations. Each interface card supports a single DS0 signaling channel.

Control Signaling Network Options

Designing your network to handle control signaling is a complex and sophisticated task beyond the scope of this document. This section briefly describes what control signaling network options are available and some network engineering guidelines to consider.

Customer-Provided Equipment

Your control network consists of a number of hubs, switches, or routers configured together to support the number of ports in your point of presence (POP), the traffic characteristics of incoming calls, the geographic location of the Cisco SS7 Interconnect for Voice Gateways Solution components, and the level of redundancy that you require. Other factors to consider are:

- Design of the network (topology and hardware components)
- Security (physical, packet encryption, packet filtering)
- Quality of service (delay, bandwidth, throughput, queuing techniques)
- Traffic segregation (access lists and route filters)
- Configuration of the components (RLM with the required SC host and access gateway/Cisco SLT redundancy, and timers)

Control traffic (signaling) should be segregated from the bearer data IP traffic (towards the internet/intranet) onto a different network. This optimizes control traffic latency and provides added security. Redundancy in your control network can be provided by duplicating your Cisco SS7 Interconnect for Voice Gateways Solution components. In the event that the control network fails or connectivity to it fails, the data network is used for signaling.

In the simplest case, your Cisco SS7 Interconnect for Voice Gateways Solution components are co-located and a pair of LAN switches serve as your control network. However, it is also possible that Cisco SLTs, and access gateways, are geographically separate from the SC hosts, requiring a control network with WAN links and separate routers to provide the WAN connection.

IP Connectivity with LAN

Figure 2-2 shows a sample continuous configuration with a mated Cisco SLT pair (for redundancy) on the control signaling network. Redundant signaling controllers support two or four Fast Ethernet connections each.

In this continuous configuration example, the control network functions are:

- Checkpointing traffic (RUDP/UDP/IP)
- Heartbeat (UDP; 50 bytes/second)
- SNMP management of components (configurable to either network)
- SC host/access gateway signaling and communications (Q.931+/Q921/UDP/IP-RLM)
- SC host/Cisco SLT signaling and communications (MTP-3+ISUP/SM/RUPD/UDP/IP)

The QoS packet network functions are:

- PSTN traffic over IP from and toward the Internet/Intranet
- H.323 access gateway traffic
- Access gateway/AAA (Radius/TACACS+server traffic)

IP Connectivity with WAN

Distributed IP control networks operating over a WAN is necessary when:

- Multiple POPs in geographically different locations are controlled by the same SC host.
- Redundant SC hosts are in geographically different locations.
- Cisco SLTs and access gateways are not co-located with the SC host.



Note

The access gateway is equipped with serial ports providing WAN termination.

IP Control Network Combinations

The following IP control network combinations are recommended:

- One single subnet for all traffic.
- Two redundant subnets: one dedicated to control traffic and the other for user data traffic and as alternative path for the control traffic.
- Four redundant subnets: two redundant subnets for Cisco SLT/SC host traffic; two redundant subnets for access gateway/SC host traffic. Note: One of these subnet pairs must also run user data traffic.
- Any combination of the above with WAN links and dedicated routers providing IP connectivity between the SC host/access gateway subnets and the SC host subnet.
- Any combination of the above with VLANs configured in shared switches.

**Note**

The subnet mentioned in your IP control network can be a dedicated hub or switch running at 10 or 100 Mbps (10 Mbps for SLTs) or a VLAN configured in a switch sharing backplane bandwidth with other VLANs.

Engineering Considerations

When engineering your network, you must consider the following issues:

- There should be no packet loss, and the packets should not be received out of order between the signaling controller and the access gateways. This could impact the performance of the Cisco SS7 Interconnect for Voice Gateways Solution, and the call setup time might become unacceptable.
- Do not enable load balancing in the control network. If you must use load balancing, then you must also enable destination-based load balancing. In this case, use Cisco Express Forwarding (CEF) if available. If you do not use CEF, load balancing could cause out-of-sequence delivery when the cache ages out.
- If you are using Weighted Fair Queuing (WFQ) or any other type of queuing feature, make sure that all signaling packets from the access gateways to the signaling controller (and vice versa) show up in the same queues. Fancy Queuing is not recommended in the control network unless absolutely necessary.
- If you are using dynamic routing protocols in the control network, out-of-sequence delivery could occur on a change of adjacency or topology. This should not be a normal occurrence in a stable network.

Cisco SS7 Interconnect for Voice Gateways Solution Components

The Cisco SS7 Interconnect for Voice Gateways Solution contains the following components:

- SC Node Products
- Access Gateways
- LAN Switches (Optional)

Figure 2-5 displays the components of the Cisco SS7 Interconnect for Voice Gateways Solution.

See the “SS7 Technology Overview” appendix for information about how the solution components operate within the SS7 hierarchy.

Figure 2-5 Cisco SS7 Interconnect for Voice Gateways Solution Components

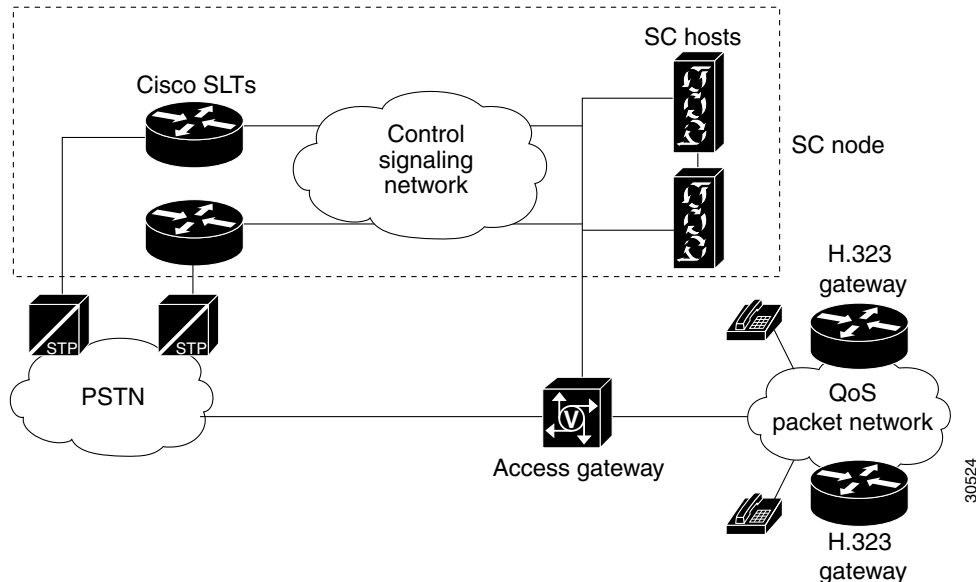

SC Node Products

The SC node is the combination of hardware and software that provides the signaling controller function and transports the signaling traffic between the SC hosts and the SS7 signaling network. The SC node in the Cisco SS7 Interconnect for Voice Gateways Solution consists of one or more SC hosts, one or more Cisco SLTs, the signaling controller software, and ancillary equipment.

SC Hosts

An SC host is a Sun hardware platform running signaling controller software.

Table 2-1 lists supported SC hosts for the Cisco SC2200 product.

Table 2-1 Supported SC Hosts

| SC Host | Description |
|---------------------------------|---|
| Sun Ultra Enterprise 450 (E450) | The Sun Ultra Enterprise 450 is a high-performance, shared-memory, multiprocessing, general-purpose Sun Ultra SPARC server. |
| |  <p>Note The Sun E450 is not NEBs compliant. Check with your Cisco representative regarding equipment availability.</p> |

Table 2-1 Supported SC Hosts (continued)

| SC Host | Description |
|------------------|---|
| Sun Netra t 112x | The Sun Netra t 112x is a general-purpose Sun Ultra SPARC server. The Sun Netra t 112x is rack-mountable and is NEBS and ETSI compliant. |
| Sun Netra t 1400 | The Sun Netra t 1400 is a fault-tolerant, dual modular, redundant architecture. Additional lockstep operations give this host the ability to isolate and recover from hardware failure. |

SC Host Features

The primary functions of the signaling controller is performing protocol conversion and call screening. The signaling controller is responsible for:

- Interworking multiple-user protocols
- Translating dialed digit information into data address information A-number and B-number analysis
- Issuing control commands to the Transport layer to create, modify, or delete a call session
- Generating comprehensive CDR on a call-by-call basis
- Providing element management information and statistics
- Providing comprehensive signaling debugging capabilities

Table 2-2 lists the features for the SC host.

Table 2-2 SC Host Features

| Feature | Support for ... |
|--|---|
| Call performance per signaling controller (simplex configuration) | <ul style="list-style-type: none"> • 50 calls per second • 30 K to 50 K ports or simultaneous calls |
| Call performance per signaling controller (continuous service configuration) | <ul style="list-style-type: none"> • 50 calls per second • 30 K to 50 K ports or simultaneous calls |
| Performance | <ul style="list-style-type: none"> • Provisioning from MML or from an SNMP manager • Dynamic reconfiguration of point codes, linksets, trunk groups, and trunks • MML commands and responses • Application-level checking of call states and circuit states |
| Signaling protocols | <ul style="list-style-type: none"> • SS7 with MTP2 configured on the Cisco SLT • Support for national protocols of many countries |
| Scaling of point codes | 250+ DPCs and 16 OPCs |
| Network management interfaces | IP |
| Faults and alarms management | SNMP traps |

Table 2-2 SC Host Features (continued)

| Feature | Support for ... |
|---|---|
| Millisecond Timestamp | Millisecond time stamps on log records of diagnostic messages, set and clear alarm messages (sets and clears), alarm messages recorded by the Data Dumper, and alarm messages in the responses for the MML commands "rtrv-alm" and "rtrv-alm:CONT". |
| Enhanced logging facility | <ul style="list-style-type: none"> • A consistent, text-based format for logging messages • Improved filtering capabilities so that the user is not overwhelmed with logged information, and so that system performance is not severely degraded when logging at higher detail levels • Dynamic control of logging throughout the system (no interruption of service when changing logging characteristics) • Separation between logging messages for developers and for end-users. |
| Configuration management | <ul style="list-style-type: none"> • Telephony Controller Manager (TCM), a TCL/tk graphic user interface (GUI) that uses simple network management protocol (SNMP) commands to provision the Cisco media gateway controller (MGC) • Man-Machine Language, a command line interface to the MGC |
| Accounting | CDR (CSV format) support for international carrier requirements |
| Resource management | <ul style="list-style-type: none"> • Keeps track of circuit IDs for assigning calls on access gateway ports • Manages adds, moves, and changes of access gateway resources |
| Performance measurements and statistics | Supports carrier requirements |
| Security | Structured system of passwords |
| Operating system | Sun Solaris 2.6.x |

Cisco SS7 Interconnect for Voice Gateways Solution Software

The Cisco SS7 Interconnect for Voice Gateways Solution SC2200 product requires the following software release levels listed in Table 2-3.

Table 2-3 SC Node Software

| Software Release Level | Support for... |
|---------------------------------------|--|
| Release 7.3 | Signaling controller software running on the SC host |
| Release c2600-ipss7-mz | Software running on the Cisco SLT |
| Cisco IOS 12.0(7)XR or later releases | Cisco IOS release running on the access gateway |
| Sun Solaris 2.6.x | Operating system running on the SC host |

Cisco SLTs

The Cisco SLT handles the incoming and outgoing SS7 messages (MTP layer 1 and 2) that arrive from the PSTN Signal Transfer Points (STPs) or Service Switching Points (SSPs). When used in the proper configurations, the Cisco SLTs improve fault tolerance by providing for multiple communications paths between the SS7 signaling network and multiple SC hosts.

Cisco SLT Features

Table 2-4 lists the features for the Cisco SLT.

Table 2-4 Cisco SLT Features

| Feature | Support for.. |
|--|---|
| SS7 link termination on a high-availability platform | SS7 network access and interconnection requires a high degree of reliability in the signaling links and associated equipment. The Cisco SLT provides the reliability of a dedicated signaling link termination device and maximizes the availability of the SS7 signaling links. |
| Distributed SS7 MTP processing | Processor-intensive parts of the SS7 Message Transfer Part (levels 1 and 2) are offloaded from the signaling controller to the Cisco SLT. This distributed MTP model allows the signaling controller to better utilize its resources to provide optimal call control. |
| Call control | Signaling backhaul provides a means for integrating the signaling link terminals into a virtual switch with the call control intelligence centralized in the signaling controller system. |
| Standard physical interfaces | Interconnection with SS7 network elements is supported using the most popular SS7 physical interface standards: T1, E1, V.35, RS-449, and RS-530. |
| Drop and Insert | Cisco T1/E1 Multiflex Voice/WAN interface cards support Drop and Insert (also called TDM Cross-Connect), which allows individual T1/E1 channels to be transparently passed, uncompressed, between T1/E1 ports. This feature enables direct termination of SS7 F-links in T1 or E1 carriers, while the remaining bearer channels are hairpinned back to a gateway device for processing. |

Access Gateways

The access gateway terminates the PSTN trunks, also referred to as bearer channels, that carry the call traffic. The PSTN trunks are T1 or E1 PRI interfaces. In addition, the access gateway performs call control (including originating and terminating call processing/signaling).



Note

Cisco IOS 12.0(7)XR or later releases run on the access gateway.

Table 2-5 lists the features for the Cisco AS5x00.

Table 2-5 Cisco AS5x00 Features

| Feature | Support for... |
|------------------------|--------------------------------|
| Continuity testing | Automated diagnostic procedure |
| Redundant Link Manager | Virtual link management |

LAN Switches (Optional)

The control signaling network for the Cisco SS7 Interconnect for Voice Gateways Solution often consists of a LAN switch and the cabling required to interconnect the solution components in an SC zone. This solution supports a LAN switch from the Cisco Catalyst switch family. This switch can extend VLANs across platforms through backbone Fast Ethernet, Gigabit, or ATM connections, when necessary.

**Note**

The Catalyst LAN switch is not provided with the Cisco SC2200 product.



Cisco SS7 Interconnect for Voice Gateways Solution Operations

This chapter provides a brief overview of unattended operations and manual control options available on your Cisco SS7 Interconnect for Voice Gateways Solution.

Unattended Operation

The following operations are described in this section:

- Understanding System Redundancy
- Understanding Automatic Switchover
- System Messages
- Call Detail Recording (CDR)
- Disk Mirroring

Understanding System Redundancy

The Cisco SS7 Interconnect for Voice Gateways Solution uses two SC hosts with software-based checkpointing and heartbeat to facilitate redundancy. The call-processing application is active on only one SC host platform at a time and switches to the standby platform under failure conditions. See the “Understanding Automatic Switchover” section.

The Session Manager software on the Cisco SLT manages the communication sessions with the SC hosts. When Cisco SLTs are used with a redundant pair of SC hosts, the Session Manager maintains separate communication sessions with each SC host in the pair. The session between the Cisco SLT and the active SC host transports the SS7 traffic, while the session between the Cisco SLT and the standby SC host provides backup. Upon SC host switchover, the Session Manager on the Cisco SLT must be instructed by the now active (formerly standby) SC to switch traffic to the now active SC host. Upon switchover, all calls answered in progress are preserved.



Note

Full system redundancy is available on continuous service configurations.

Understanding Automatic Switchover

The Cisco SS7 Interconnect for Voice Gateways Solution offers the continuous service configuration to protect your system against failures and downtime. A feature enhancement to RLM (Version 2) provides redundancy at the link and signaling controller level for added switchover. When each RLM group has multiple signaling controllers associated with an NAS, a signaling controller priority and link priority are examined by the RLM client (RLM software on the NAS) during switchover, ensuring improved control handling.

The switchover system consists of two signaling controllers (either dual Sun E450s or Sun Netras) connected through IP, as shown in Figure 3-1. One SC functions as the active host, while the other SC functions as the standby host. The switchover system provides a seamless transition to the standby host in case of system failures.

The active host maintains communications between the active and standby hosts. The standby host constantly checks the active host for new and changed configurations and updates itself on a regular basis. When the standby host becomes the active host, its configuration mirrors that of the former active host without losing the link with the NAS, thus preserving calls.

Figure 3-1 Switchover Processes on the Signaling Controller Hosts

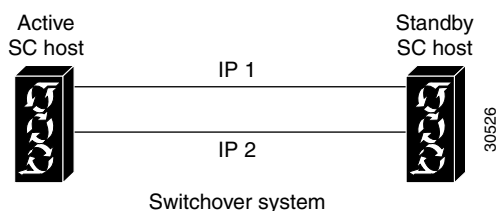

System Messages

The Cisco signaling controller software generates system messages that provide you with call processing, management, configuration and alarm status.

Status messages include these types:

- Man-Machine Language (MML) responses

After you enter an MML command, one of the following messages is generated: MML status, MML error code, auto-generated or autonomous, and alarm.

- Portable Execution Environment (PXE) Log Messages

The Portable Execution Environment (PXE) logging system sends messages to log files determined during the client initialization period.

The PXE log server software takes messages initiated by various applications (other software processes) within the Cisco signaling controller software, formats the messages, and sends them to the appropriate files. The PXE log server also adds a time stamp, an application identifier (also known as a service ID or service name), a process identifier (that is, the UNIX process), and a log level.

- Cisco signaling controller console messages generated by the UNIX operating system

For detailed information about system messages, see these Cisco SS7 Interconnect for Voice Gateways Solution documents:

- *Cisco Media Gateway Controller Software Release 7 Operations, Maintenance, and Troubleshooting Guide*
- *Cisco Media Gateway Controller Software Release 7 Reference Guide*

Call Detail Recording (CDR)

CDRs are comprised of call data elements (CDEs). The CDE is the data element (field) that includes a basic information field within a billing record. Examples of CDEs are the calling number, called number, and so on. The call data block (CDB) consists of several CDEs, related to a certain point in call (PIC).

For detailed information about CDEs and CDBs and an overview of the Cisco Signaling Controller billing system, see these Cisco SS7 Interconnect for Voice Gateways Solution documents:

- *Cisco Media Gateway Controller Software Release 7 Operations, Maintenance, and Troubleshooting Guide*
- *Cisco Media Gateway Controller Software Release 7 Installation and Configuration Guide*

Disk Mirroring

Disk mirroring is a feature that duplicates the information contained in a file system by using two disk partitions located on separate physical disks. In the event of a physical disk failure, the file system continues to operate using the unaffected disk.

Disk mirroring is used on fault-tolerant configurations with the Sun Netra t 1400 server platform. This feature increases the availability of the Cisco SC2200 by keeping the system operating when a physical disk fails—a mirrored disk can be removed and replaced while the system remains active. With redundant SC hosts using disk mirroring, a single disk failure does not cause switchover, as described in the “Understanding System Redundancy” section.

The Volume Manager software running on your Cisco SC2200 provides this feature in a transparent manner so that the application software does not know that there are multiple disk partitions making up the file system.

For detailed information about how to install disk mirroring through Volume Manager, see the *Cisco Media Gateway Controller Software Release 7 Installation and Configuration Guide*.



Note

Disk mirroring is optional on the Sun Netra t 112x and Sun Ultra E450 server platforms.

Manual Control Options

The Cisco signaling controller includes two tools that you can use to provision the software: the Cisco MGC Manager (CMM) graphical user interface (GUI) application and the Man-Machine Language (MML) Command Line Interface (CLI) application.

CMM makes provisioning easier for less-experienced administrators by listing all the components that need to be configured and by providing windows that display all configuration parameters for each component. Instructions for provisioning with CMM can be found in the *Cisco Media Gateway Controller Software Release 7 Provisioning Guide*.

Although MML provisioning requires more keystrokes, quick provisioning updates can sometimes be made faster with MML commands, because you don't have to go through the process of launching CMM. MML commands entered into a text file can be batched from the UNIX command line to speed up provisioning, and you can copy and modify MML scripts to configure additional MGC switches. For information on provisioning with MML, refer to the *Cisco Media Gateway Controller Software Release 7 Provisioning Guide*.

You can use both CMM and MML to provision the Cisco signaling controller. However, you can use only one of these tools at a time for actual configuring. Table 3-1 lists some of the features of CMM and MML and provides guidelines for selecting between the two tools.

Table 3-1 CMM and MML Features

| Specifications/Features | CMM | MML |
|--|---|--|
| System Basics | X-windows GUI front end, SNMP back end | CLI that interacts directly with the Cisco signaling controller. |
| System Hardware/Software Requirements | SC host server running Solaris 2.6 OS Running the TCM on the same server as the Cisco signaling controller can adversely impact performance. Cisco recommends using a separate server. | Runs on the SC host server. |
| Batch File Support | No | Yes |
| Level of Network/Telephony Experience Required | Little experience required; very easy to use. | Requires a high level of experience with MML and the Cisco Signaling Controller software. |
| Best Used For | <ul style="list-style-type: none"> Setting up a single configuration or few configurations on individual SC host servers. Modifying an existing configuration. | <ul style="list-style-type: none"> Creating batch files to configure many SC host servers or retrieve measurements. Modifying configurations (experienced users). Scaling large configurations. |



Cisco SS7 Interconnect for Voice Gateways Solution Implementation

This chapter describes how to implement the Cisco SS7 Interconnect for Voice Gateways Solution by installing and configuring the components. The following sections describe the tasks:

- Implementation Task List
- Hardware Installation
- Signaling Controller Software Installation
- Signaling Controller Software Configuration
- Access Gateway Installation and Configuration
- Gatekeeper Installation and Configuration (Optional)
- Operation and Maintenance

Implementation Task List

To implement your Cisco SS7 Interconnect for Voice Gateways Solution, you must:

-
- Step 1** Design your network by identifying the physical configuration and components of your network. This network design should be based on assumptions that meet your network requirements. Plan your design to include the following:
- a. Signaling routes to external switches
 - b. Signaling links to signaling points
 - c. Network access server control links
 - d. Trunks, trunk groups, and QoS packet network routes
- See the *Cisco Media Gateway Controller Software Release 7 Provisioning Guide* for details.
- Step 2** Create a dial plan. See the *Cisco Media Gateway Controller Software Release 7 Provisioning Guide* for details.
- Step 3** Connect the signaling controller hardware. See the “Hardware Installation” section for details.
- Step 4** Connect the Cisco SLT and LAN switch to the signaling controller. See the “Hardware Installation” section for details.

- Step 5** Install the operating system software and signaling controller software on the signaling controller host. See the “Signaling Controller Software Installation” section for details.
- Step 6** Configure the software on the signaling controller. See the “Configuring the Signaling Controller” section for details.
- Assign an IP address to the signaling controller and then create and deploy the configuration file on the signaling controller.
 - Configure the TCM server and assign an IP address to the server.
- Step 7** Configure the software on the Cisco SLT. See the “Configuring the Cisco SLT” section for details.
- Step 8** Configure the software on the LAN switch. If you are using a Cisco Catalyst switch, see the “Configuring the LAN Switch (Optional)” section for details.
- Step 9** Install the access gateway. See the “Access Gateway Installation and Configuration” section for details.
- Connect the access gateway to the LAN switch.
 - Connect the access gateway to the Public Switched Telephone Network (PSTN).
 - Configure and assign IP addresses to the access gateways. See the section “Access Gateway Installation and Configuration” for details.
- Step 10** Configure the network management server. See the “Operation and Maintenance” section for details.
- Step 11** Make sure that all the devices can talk to each other by pinging one device from another. For example, you should be able to ping the media router and the DNS server (node in the Internet cloud) from each device. You should also be able to access (using Telnet, ReflectionX, or other such software) each device from the other devices.
-

Hardware Installation

This section provides an overview of the recommended hardware connection sequence. For details, refer to the appropriate hardware installation guide. Make sure that you have the hardware installation guides handy for all the devices you are connecting in your system.

Signaling Controller Installation

Installing the signaling controller hardware involves wiring the signaling controller in this sequence:

| | Task | Reference |
|--------|---|---|
| Step 1 | If using dedicated DC power, connect the power supply to the signaling controller. | <i>Cisco Media Gateway Controller Hardware Installation Guide</i> |
| Step 2 | Connect the LAN switch to your LAN. | |
| |  Note The switch is not provided with the signaling controller. | |
| Step 3 | Connect a console terminal to the signaling controller using an EIA/TIA-232 cable. | |
| Step 4 | Connect the signaling controller to the IP network to which the access gateways will be connected. | |

Cisco SLT Installation

Installing the SLT hardware involves connecting the Cisco SLTs in this sequence:

| | Task | Reference |
|--------|--|--|
| Step 1 | Connect serial ports through the T1/E1, V.35, RS-449, or RS-530 interfaces to the STPs. | <ul style="list-style-type: none"> <i>Cisco Media Gateway Controller Hardware Installation Guide</i> Cisco IOS Release 12.0(7)XR documentation, <i>Cisco Signaling Link Terminal</i> |
| Step 2 | Connect Ethernet ports through the Ethernet 10BaseT to the signaling controller or the LAN switch. | |

Network Access Installation

Installing the network access hardware involves the following:

| Task | Reference |
|---|--|
| <p>Step 1 If you have one IP network, connect the access gateways to the LAN switch.</p> <p>If you have two IP networks, use the access gateway Ethernet port to connect each access gateway to the POP management network, and use the access gateway Fast Ethernet port to connect each access gateway to the IP data network.</p> | <p><i>Cisco Media Gateway Controller Hardware Installation Guide</i></p> |
| <p>Step 2 Connect the bearer channels to the access gateway using RJ-48 connections for the E1 and T1 interfaces.</p> | |

Signaling Controller Software Installation

This section provides an overview of the recommended hardware connection sequence. For details, refer to the appropriate hardware installation guide. Make sure that you have the hardware installation guides handy for all the devices you are connecting in your system.

| | Task | Reference |
|---------------|---|---|
| Step 1 | Install the operating system on the signaling controller: <ol style="list-style-type: none"> 1. Verify SC host firmware. 2. Install the Sun Solaris operating system. 3. Install the Volume Manager. 4. Create the Log and Spool volumes. | <i>Cisco Media Gateway Controller Software Release 7 Installation and Configuration Guide</i> |
| Step 2 | Install the Cisco SC host software: <ol style="list-style-type: none"> 1. Install the software for a single-host or dual-host configuration. 2. Configure the execution environment. 3. Terminate the signaling links. 4. Configure the SNMP support resources. | |
| Step 3 | Install IOS Release software on the Cisco SLT. To determine the correct software release version, refer to <i>Release Notes for Cisco Media Gateway Controller Software Release 7</i> . | <ul style="list-style-type: none"> • <i>Cisco Media Gateway Controller Software Release 7 Installation and Configuration Guide</i> • <i>Release Notes for Cisco Media Gateway Controller Software Release 7</i> |

Signaling Controller Software Configuration

Configuring the signaling controller software consists of three tasks:

- Configuring the Signaling Controller
- Configuring the Cisco SLT
- Configuring the LAN Switch (Optional)

Configuring the Signaling Controller

Caution

Always use the Cisco signaling controller CMM tool or MML commands to create, modify, manage, and deploy your configuration files on the signaling controller. We do not recommend modifying the configuration files directly on the signaling controller.

Configuring the signaling controller includes these steps:

| Task | Reference |
|--|---|
| Step 1 Prepare the following: <ul style="list-style-type: none"> • Bearer routes to other switches • Signaling point links • Network access server control links • Trunks, trunk groups, and routes • Dial plans | <i>Cisco Media Gateway Controller Software Release 7 Installation and Configuration</i> |

| Task | Reference |
|---|---|
| <p>Step 2 Configure the SS7 signaling routes to external switches by completing the following tasks:</p> <ul style="list-style-type: none"> • Add the OPC in your network. • Add the DPC to identify the destination switch. • Add the APCs to identify the STPs with which the signaling controller communicates signaling information. • Add linksets to connect the Cisco SLTs to the STPs. • Add the SS7 subsystem to identify the mated STPs. • Add the SS7 routes for each signaling path from the signaling controller to the destination switch. • Add the SS7 signaling service from the signaling controller to the destination switch. | <p><i>Cisco SS7 Interconnect for Access Servers and Voice Gateways Solutions Provisioning Guide</i></p> |
| <p>Step 3 Provision the signaling links by completing the following tasks:</p> <ul style="list-style-type: none"> • Add the Ethernet adapters (cards) in the SC host that carry signaling to and from the Cisco SLTs. • Add Ethernet interfaces for the cards in the host. • Add C7 IP links for each SS7 link from the signaling controller to the SS7 network (through the Cisco SLT). | |
| <p>Step 4 Configure the access gateway control links by completing the following tasks:</p> <ul style="list-style-type: none"> • Add external nodes for the access gateways in your network. • Add NAS signaling services for each access gateway. • Add IP links for each access gateway to each Ethernet card in the SC host. | |
| <p>Step 5 Configure trunks, trunk groups, and routes.</p> | |
| <p>Step 6 Provision black and white trunk screening.</p> | |
| <p>Step 7 Build and deploy the configuration.</p> | |

Configuring the Cisco SLT

Configuring the Cisco SLTs includes these steps:

| | Task | Reference |
|---------------|---|---|
| Step 1 | Identify the serial WAN interface card on your Cisco SLT and connect cable to card as described in Steps 1 and 2 of the “Cisco SLT Installation” section on page 4-3. | <i>Cisco Media Gateway Controller Software Release 7 Installation and Configuration Guide</i> |
| Step 2 | Install the Cisco SLT image software. | |
| Step 3 | Configure the basic parameters and SS7 links for the Cisco SLT. | |
| Step 4 | Configure Session Manager and RUDP. | |
| Step 5 | Save the new configuration as the startup configuration, and then reload the Cisco SLT. | |

For additional details, refer to the following documents:

- *Quick Start Guide Cisco 2600 Series Cabling and Setup*
- *Cisco 2600 Series Hardware Installation Guide*
- *Cisco 2600 Network Module Hardware Installation Guide*
- *Cisco 2600 WAN Interface Cards Hardware Installation Guide*
- *Cisco 2600 Software Configuration Guide*
- *New and Changed Show Commands for Cisco 2600 Series Routers*
- *Cisco 2600 Series Configuration Notes*



Tips

The Cisco publications are available online on the Cisco web site or on the Cisco Documentation CD-ROM that arrived with your system.

Configuring the LAN Switch (Optional)

This section describes the task of configuring LAN switches (Cisco Catalyst Switch family) for your solution. The LAN switch connects the SC hosts to the access gateways or the Cisco SLTs. The LAN switch is used in the SC node to extend VLANs across platforms through backbone Fast Ethernet, Gigabit, or ATM connections, when necessary. The LAN switch is not provided with the SC host. Configuring the LAN switch includes these steps:

| | Task | Reference |
|----------------|--|---|
| Step 1 | Make sure that you have virtual LAN assignments and IP address assignments for solution devices. | <i>Cisco Media Gateway Controller Software Release 7 Installation and Configuration Guide</i> |
| Step 2 | Configure basic system information. | |
| Step 3 | Configure the logical interface. | |
| Step 4 | Configure SNMP information. | |
| Step 5 | Configure the virtual LANs (VLANs). | |
| Step 6 | Configure module and port parameters. | |
| Step 7 | Configure spanning-tree parameters. | |
| Step 8 | Configure the standby ports. | |
| Step 9 | Configure the ISL connections between switches. | |
| Step 10 | Configure the Switch Port Analyzer. | |
| Step 11 | Configure the Route Switch Module. | |

Access Gateway Installation and Configuration

To install the access gateway, perform the following tasks:

| | Task | Reference |
|--------|---|---|
| Step 1 | Rack-mount the access gateway chassis. | <i>Cisco SS7 Interconnect for Access Servers and Voice Gateways Solutions Media Gateway Guide</i> |
| Step 2 | Connect the access gateway to the network as described in Steps 1 and 2 of the “Network Access Installation” section on page 4-4. | |
| Step 3 | Connect a console terminal and auxiliary ports. | |
| Step 4 | Supply power to the access gateway. | |

For each access gateway installed in your Cisco SS7 Interconnect for Voice Gateways Solution, configure the access gateway by performing the following tasks:

| | Task | Reference |
|--------|---|---|
| Step 1 | Configure the switch type to NI2, using the isdn switch-type primary-ni command. (This command enables the connection between the access gateway and the virtual switch controller.) | <i>Cisco SS7 Interconnect for Access Servers and Voice Gateways Solutions Media Gateway Guide</i> |
| Step 2 | Configure the access server for channelized T1 or E1 lines. | |

To install the optional access gateway software features supported on your Cisco SS7 Interconnect for Voice Gateways Solution, perform the following tasks:

| Task | Reference |
|--|--|
| Configure Continuity Testing (COT) | Cisco IOS Release 12.0(3)T documentation <ul style="list-style-type: none"> <i>Continuity Testing (COT)</i> |
| Configure the Redundant Link Manager (RLM) | <i>Cisco SS7 Interconnect for Access Servers and Voice Gateways Solutions Media Gateway Guide</i> Cisco IOS Release 12.0(7)XR documentation <ul style="list-style-type: none"> <i>Cisco H.323 VoIP with SS7 for the Cisco AS5300</i> |

To install and configure Voice over IP on your Cisco SS7 Interconnect for Voice Gateways Solution, see the following reference documentation:

Reference

Voice over IP for the Cisco AS5300 Universal Access Server Software Configuration Guide

Gatekeeper Installation and Configuration (Optional)

Your Cisco SS7 Interconnect for Voice Gateways Solution may include a gatekeeper. To install and configure Voice over IP on the Cisco 3640 gatekeepers, see the following reference documentation:

Reference

Cisco IOS Release 12.1 Voice, Video, and Home Applications Configuration Guide

Cisco IOS Release 12.1 Voice, Video, and Home Applications Command Reference

Operation and Maintenance

Under normal conditions, the primary (active) signaling controller application (MTP3 and the Call Processing Engine) processes calls. In addition to normal call processing, in a fault-tolerant configuration the primary signaling controller updates the standby signaling controller with call state information when a call enters the establish phase. This ensures that the call state is maintained in case of failure.

The following are normal operating procedures for the signaling controller:

- Managing signaling channels and lines
- Managing traffic channels
- Managing switchover

The following are operating procedures under various equipment failure scenarios:

- Signaling link termination failure
- Call processor failure
- Operating system failure
- LAN switch failure

The following are maintenance tasks necessary for each component in your Cisco SC2200:

- Checking equipment status
- Preventive maintenance
- Removing the component from your system
- Replacing the component

For detailed instructions on these operation procedures and maintenance tasks, see the *Cisco Media Gateway Controller Operations, Maintenance, and Troubleshooting Guide*.

Configuring Other Components

Refer to the documentation that shipped with a particular component for configuration information.

Getting Help

You have 24-hour support for your Cisco SS7 Interconnect for Voice Gateways Solution through Cisco's Technical Assistance Center (TACs). There are four TACs worldwide. To initiate a case, contact the closest TAC and tell them your problem. You will be issued a case number that you can check by using the phone or the Web. See Table 4-1 for a list of telephone numbers you can call.

Table 4-1 TAC Telephone Numbers

| Region | Telephone |
|---------------|--|
| Asia-Pacific | +61 2 9935 4107 |
| Australia | 1 800 805 227 |
| China | 10810, then 800 501 2306 – Mandarin 10811, then 800 501 2306 – English 800 810 8886 – in country TAC support |
| Europe | +32 2 778 4242 |
| France | 0590 7594 |
| Hong Kong | 800 96 5910 |
| India | 000 117 then 888 861 6453 |
| Indonesia | 001 800 61 838 |
| Japan | 0066 33 800 926 0120 086771 – in country TAC partners |
| Korea | 00798 611 0712 – Seoul 00 911, then 888 861 5164 |
| Malaysia | 1 800 805880 |
| New Zealand | 0800 44 6237 |
| North America | 1 800 553 2447 1 408 526 7209 |
| Philippines | 1800 611 0056 |
| Seoul | 00 911 then 888 861 5164 |
| Singapore | 800 6161 356 |
| Taiwan | 0080 61 1206 |
| Thailand | 001 800 611 0754 |
| UK | 0800 960 547 |

Cisco TAC also offers support in several languages during business hours and in English after business hours. You can send e-mail to the e-mail addresses listed in Table 4-2 and receive answers in the language indicated in the table.

Table 4-2 TAC E-mail Address

| Language | E-mail Address |
|------------------|-----------------------|
| English/Spanish | tac@cisco.com |
| Hangul (Korean) | korea-tac@cisco.com |
| Hanzi (Chinese) | chinese-tac@cisco.com |
| Kanji (Japanese) | japan-tac@cisco.com |
| Thai | thai-tac@cisco.com |

You can also initiate your case online through the internet at www.cisco.com. Outside these locations, contact the Cisco regional sales office nearest you, or contact your local authorized Cisco distributor.

Where to Get the Latest Version of This Guide

The hard copy of this publication is updated at major releases only and does not always contain the latest material for enhancements occurring between major releases. Cisco ships separate release notes or configuration notes for spares, hardware, and software enhancements that occur between major releases.

The online copy of this guide is always up to date and integrates the latest enhancements to the product. You can access the current online copy of this guide on the World Wide Web at <http://www.cisco.com>, <http://www-china.cisco.com>, or <http://www-europe.cisco.com>.

Hotlinks to Online Documentation

The Web provides the following documentation related to the Cisco SS7 Interconnect for Voice Gateways Solution:

-
- Media Gateway Controller Release 7 Documentation:
http://lbj.cisco.com/push_targets1/ucdit/cc/td/doc/product/access/sc/re17/index.htm

 - *Cisco Dial Solutions Quick Start Guide*:
<http://www.cisco.com/univercd/cc/td/doc/product/software/ios120/12supdoc/dsqcg3/index.htm>

 - *Cisco Dial Solutions Configuration Guide*:
http://www.cisco.com/univercd/cc/td/doc/product/software/ios113ed/113ed_cr/dial_c/index.htm

 - *Cisco Dial Solutions Command Reference*:
http://www.cisco.com/univercd/cc/td/doc/product/software/ios113ed/113ed_cr/dial_r/index.htm

 - Cisco IOS Release 12.0(7)XR documentation, *Cisco H.323 VoIP with SS7 for the Cisco AS5300 Universal Access Server*
http://lbj.cisco.com/push_targets1/ucdit/cc/td/doc/product/access/acs_serv/5300/cfios/h3ss7_tv.htm

-
- Cisco Network Access Server configuration:
http://www.cisco.com/univercd/cc/td/doc/product/software/ios113ed/113aa/113aa_7/rlm_rel2.htm
http://www.cisco.com/univercd/cc/td/doc/product/software/ios113ed/113aa/113aa_5/cot.htm
http://www.cisco.com/univercd/cc/td/doc/product/access/acs_serv/as5200/index.htm
http://www.cisco.com/univercd/cc/td/doc/product/access/acs_serv/5300/index.htm
http://www.cisco.com/univercd/cc/td/doc/product/access/acs_serv/as5800/index.htm
 - *Cisco Signaling Link Terminal*:
http://www.cisco.com/univercd/cc/td/doc/product/access/acs_mod/cis2600/ios_feat/0219nomd.htm
 - Cisco Access Server documentation:
http://www.cisco.com/univercd/cc/td/doc/product/access/acs_serv/index.htm
 - Cisco AccessPath system documentation:
<http://www.cisco.com/univercd/cc/td/doc/product/access/ap/index.htm>
 - Cisco Access Server Release Notes:
http://www.cisco.com/univercd/cc/td/doc/product/access/acs_serv/5300/iosrn/index.htm
 - SS7 tutorial:
<http://www.iec.org/>
 Click Training, Web ProForum Tutorials, Communications Networks, and then scroll down the list and click Signaling System #7 (SS7).
-

If You Need More Information

The Cisco IOS software running on your router contains extensive features and functionality. The effective use of many of these features is easier if you have more information. For additional information on configuring and maintaining a signaling controller, the following documentation resources are available:

- Cisco Documentation CD-ROM

Cisco documentation and additional literature are available on a CD-ROM, which ships with your product. The Documentation CD-ROM, a member of the Cisco Connection Family, is updated monthly; therefore, it might be more up to date than printed documentation. To order additional copies of the Documentation CD-ROM, contact your local sales representative or call customer service. The CD-ROM is available as a single item or as an annual subscription. You can also access Cisco documentation on the World Wide Web at <http://www.cisco.com>, <http://www-china.cisco.com>, or <http://www-europe.cisco.com>.

If you are reading Cisco product documentation on the World Wide Web, you can submit comments electronically. Click **Feedback** on the toolbar and select **Documentation**. After you complete the form, click **Submit** to send it to Cisco. We appreciate your comments.



Note You can access Cisco IOS software configuration documentation on the World Wide Web at <http://www.cisco.com>, <http://www-china.cisco.com>, or <http://www-europe.cisco.com>

- For Cisco IOS software configuration information, refer to the modular configuration and modular command reference publications in the Cisco IOS software configuration documentation set that corresponds to the software release installed on your Cisco hardware.
- To obtain general information about documentation, refer to the section “Cisco Connection Online,” or call customer service at 800 553-6387 or 408 526-7208. Customer service hours are 5:00 a.m. to 6:00 p.m. Pacific time, Monday through Friday (excluding Cisco-observed holidays). You can also send e-mail to cs-rep@cisco.com, or you can refer to the *Cisco Information Packet* that shipped with your router.

Cisco Connection Online

Cisco Connection Online (CCO) is Cisco Systems’ primary, real-time support channel. Maintenance customers and partners can self-register on CCO to obtain additional information and services.

Available 24 hours a day, 7 days a week, CCO provides a wealth of standard and value-added services to Cisco’s customers and business partners. CCO services include product information, product documentation, software updates, release notes, technical tips, the Bug Navigator, configuration notes, brochures, descriptions of service offerings, and download access to public and authorized files.

CCO serves a wide variety of users through two interfaces that are updated and enhanced simultaneously: a character-based version and a multimedia version that resides on the World Wide Web (WWW). The character-based CCO supports Zmodem, Kermit, Xmodem, FTP, and Internet e-mail, and it is excellent for quick access to information over lower bandwidths. The WWW version of CCO provides richly formatted documents with photographs, figures, graphics, and video, as well as hyperlinks to related information.

You can access CCO in the following ways:

- WWW: <http://www.cisco.com>
- WWW: <http://www-europe.cisco.com>
- WWW: <http://www-china.cisco.com>
- Telnet: cco.cisco.com
- Modem: From North America, 408 526-8070; from Europe, 33 1 64 46 40 82. Use the following terminal settings: VT100 emulation; databits: 8; parity: none; stop bits: 1; and connection rates up to 28.8 kbps.

For a copy of CCO’s Frequently Asked Questions (FAQ), contact cco-help@cisco.com. For additional information, contact cco-team@cisco.com.



Note

If you are a network administrator and need personal technical assistance with a Cisco product that is under warranty or covered by a maintenance contract, contact Cisco’s Technical Assistance Center (TAC) at 800 553-2447, 408 526-7209, or tac@cisco.com. To obtain general information about Cisco Systems, Cisco products, or upgrades, contact 800 553-6387, 408 526-7208, or cs-rep@cisco.com.

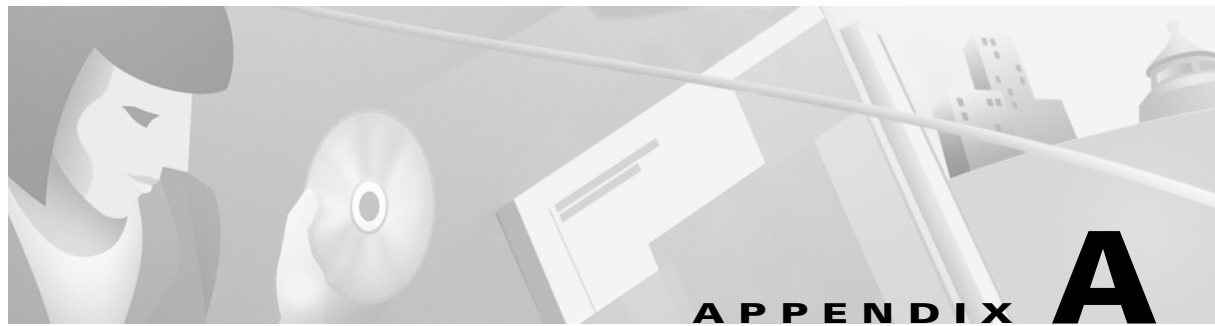

SS7 Technology Overview

SS7 Technology Overview

SS7 is a set of standards for the Common Channel Signaling (CCS) system. Historically, SS7 defines the architecture, network elements, interfaces, protocols, and management procedures for a Public Switched Telephone Network (PSTN) that transports control information between network switches and between switches and databases. SS7 is used between the PSTN switches; replacing per-trunk, in-band signaling.

Typically, SS7 is implemented on a separate data network within the PSTN and provides call setup and teardown, network management, fault resolution, and traffic management services. The SS7 network is used solely for network control, and the only data sent over it is signaling messages. (Note that the term SS7 can be used to refer to the SS7 protocol, the signaling network, or the signaling network architecture.)

The SS7 protocols that convey signaling information between switching systems (called signaling points) in the PSTN are carried on a special overlay network used exclusively for signaling. The signaling points use routing information in the SS7 signals to transfer calls to their final destinations.

The SS7 network features include:

- Control over the establishment of calls across the PSTN.
- Routing, billing, information exchange functions, specialized call treatments, and enhanced routing.
- Common channel signaling in which signaling information for different connections travels on separate dedicated signaling channels.
- Voice and data connections that travel on bearer channels.

Figure A-1 is a graphic representation of SS7 links and how they are used in an SS7 signaling network.

Figure A-1 SS7 Signaling Network

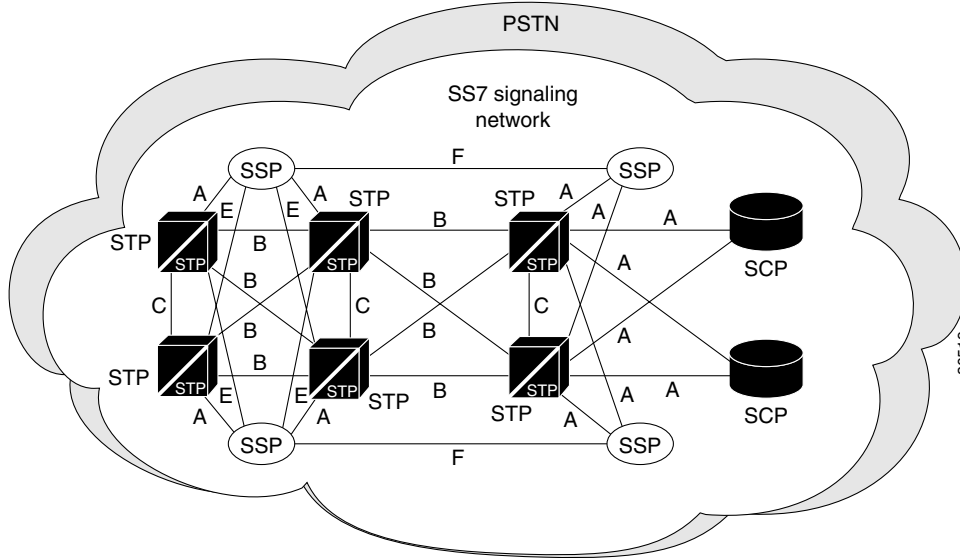

The SS7 architecture consists of the following signaling points (as shown in Figure A-1):

- Service Switching Points (SSPs) are telephone switches equipped with SS7 software and signaling links. Each SSP is connected to both STPs in a mated pair.
- Signal Transfer Points (STPs) receive and route incoming signaling messages toward their destinations. STPs are deployed in mated pairs and share the traffic between them.
- Service Control Points (SCPs) are databases that provide the necessary information for special call processing and routing, including 800 and 900 call services, credit card calls, local number portability, cellular roaming services, and advanced call center applications.

As you can see in Figure A-1, the SCPs and STPs and their links are deployed as mated pairs because of the critical nature of the signaling network.

Point Codes

Each signaling point (also called an SS7 node or SP) in the SS7 network is identified with a unique address called a point code (PC). ANSI point codes are 24-bit and ITU point codes are 14-bit. PCs are carried in signaling messages exchanged between signaling points to identify the source and destination of each message. PCs are managed by the government agency that supervises, licenses, and controls electronic and electromagnetic transmission standards in your country. Note that there could be two separate agencies managing policy and providing licenses in your country.



Note

When using STPs, multiple signaling links between the same nodes (point-to-point) share traffic and are referred to as linksets.

The PC is a hierarchical address consisting of:

- Network identification—Identifies a signaling network.
- Network cluster—Identifies a cluster of nodes belonging to a signaling network. For example, you can address a group of nodes by using the same mated pair of STPs as a network cluster.
- Network cluster member—Identifies a single signaling point within a cluster.

Figure A-2 Point Codes in the SS7 Network

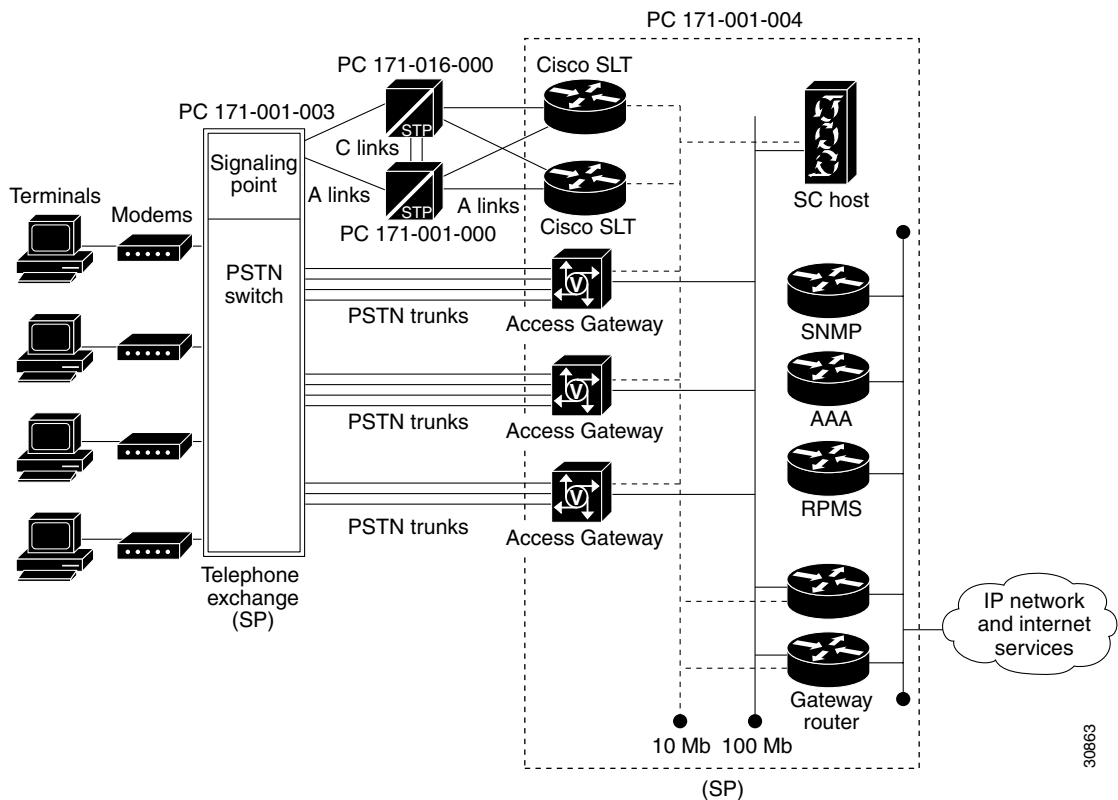

In Figure A-2, C-links (cross links) connect STPs together to form mated pairs (PC 171-016-000 and PC 171-001-000). A-links (access links) connect STPs with the telephone exchange signaling point (PC 171-001-003) and with the redundant pair of Cisco SLTs of the Cisco MGC signaling point.



Note

These point codes are in ANSI SS7 point code format. Variations of SS7 might use different point code formats. The network-cluster-member format is only valid with ANSI SS7 point code formats.

The PC 171-016-000 used for one of the mated STPs consists of the following elements:

- 171 is the network identification.
- 016 is the network cluster representing only the top STP in Figure A-2.
- 000 is the network cluster member, which is connected to the network cluster.

Reference Documentation

See the following publications and web site for a comprehensive overview of SS7:

- Black, U. *ISDN and SS7 Architecture for Digital Signaling Networks*. Upper Saddle River, New Jersey: Prentice Hall PTR; 1997
- Bellamy, J. *Digital Telephony*, Second Edition. New York, New York; John Wiley and Sons, Inc.; 1991.
- <http://www.iec.org/>. Click **Training, Web ProForum Tutorials, Communications Networks**, and then scroll down the list and click **Signaling System #7 (SS7)**.

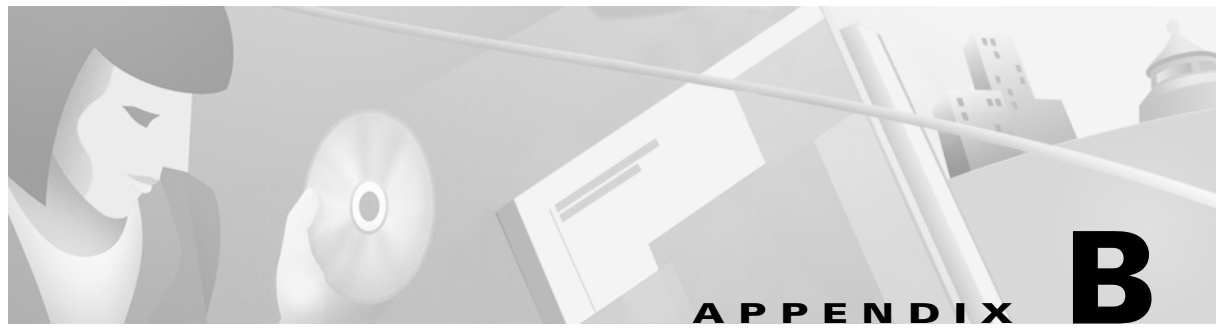

Voice over IP Overview

Voice over IP Overview

The Cisco SS7 Interconnect for Voice Gateways Solution builds on existing Cisco H.323 Voice over IP (VoIP) architecture that consists of a Cisco AS5x00 access gateway and Cisco 2600 or 3600 series routers operating as gatekeepers within an H.323 infrastructure. This architecture provides the quality of service (QoS), stability, and functionality necessary for carrier class, real-time IP communications services.

Figure B-1 illustrates the gateway and gatekeeper internetworking functionality in detail.

Figure B-1 VoIP PSTN Signaling Architecture

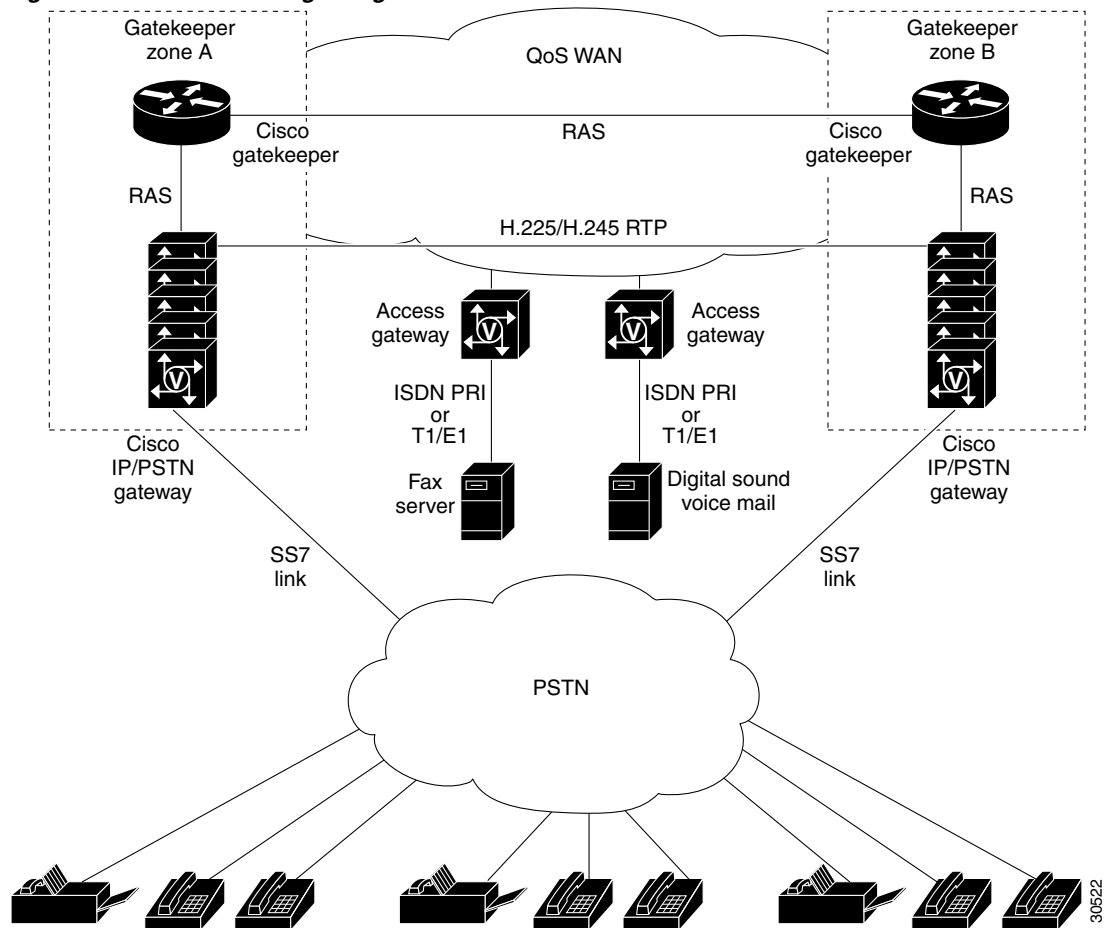

How VoIP Processes a Telephone Call

It helps to understand what happens at an application level when you place a call using VoIP. The general flow of a two-party voice call using VoIP is as follows:

- Step 1** The user picks up the handset; this signals an off-hook condition that is generated by the PBX or end-office SSP in the PSTN.
- Step 2** The SSP provides digit analysis and route determination, then generates dial tone and sends an IAM to the signaling application part of VoIP in the gateway.
- Step 3** The VoIP issues an alerting/ACM that indicates to the SSP to start the dial tone or busy tone (based on the state of the receiving end).
- Step 4** Upon dial tone, the user dials the telephone number; those numbers are accumulated and stored by the session application.
- Step 5** After enough digits are accumulated to match a configured destination pattern, the telephone number is mapped to an IP host through the dial plan mapper. The IP host has a direct connection to either the destination telephone number or a PBX that is responsible for completing the call to the configured destination pattern.

- Step 6** The session application then runs the H.323 session protocol to establish a transmission and a reception channel for each direction over the IP network. If the call is being handled by a PBX, the PBX forwards the call to the destination telephone. If Resource Reservation Protocol (RSVP) has been configured, the RSVP reservations are put into effect to achieve the desired quality of service (QoS) over the IP network.
- Step 7** The codecs are enabled for both ends of the connection and the conversation proceeds using RTP/UDP/IP as the protocol stack.
- Step 8** Any call-progress indications (or other signals that can be carried in-band) are cut through the voice path as soon as an end-to-end audio channel is established. Signaling that can be detected by the voice ports (for example, in-band dual tone multifrequency [DTMF] digits after the call setup is complete) is also trapped by the session application at either end of the connection and carried over the IP network encapsulated in RTP Control Protocol (RTCP), using the RTCP APP extension mechanism.
- Step 9** When either end of the call hangs up, the RSVP reservations are torn down (if RSVP is used) and the session ends. Each end becomes idle, waiting for the next off-hook condition to trigger another call setup.

Key Elements

The key elements of the H.323 VoIP architecture are:

- Gateways
- Gatekeepers
- Gatekeeper Zones
- H.323 Terminals

Gateways

In the Cisco H.323 VoIP with SS7 Solution, the Cisco AS5300 operates as the VoIP gateway and dial-up remote access server. When equipped with voice feature cards (VFCs) and voice-enabled Cisco IOS software the Cisco AS5300 supports carrier-class VoIP and fax over IP services.

Gateways allow H.323 terminals and routers to communicate with terminals running other protocols. They provide protocol conversion between terminals and routers running different types of protocols. A gateway is the point at which a circuit-switched call is encoded and repackaged into IP packets.

An H.323 gateway is an endpoint on the LAN that provides real-time, two-way communications between H.323 terminals on the LAN and other H.323 terminals in the WAN, or to another H.323 gateway.

A VoIP gateway has two primary applications. It can terminate a call from the PSTN and provide user admission control using integrated voice response (IVR) and provide accounting records for the call. The gateway also can direct the call to the destination or can terminate the call from another gateway and send the call to the PSTN. The gateway (in this document) refers to the voice-capable platform with voice cards and the VoIP image.

Figure B-2 and Figure B-3 illustrate these two applications. The VoIP gateway used in this solution is the Cisco AS5300.

Figure B-2 VoIP Used as a PSTN Gateway for Internet Telephone Traffic

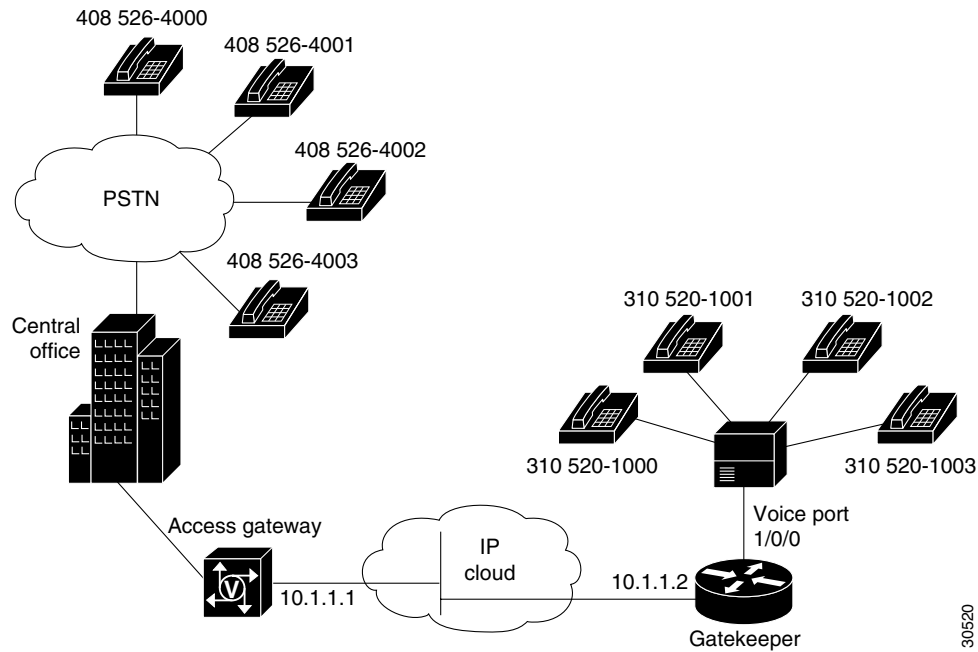
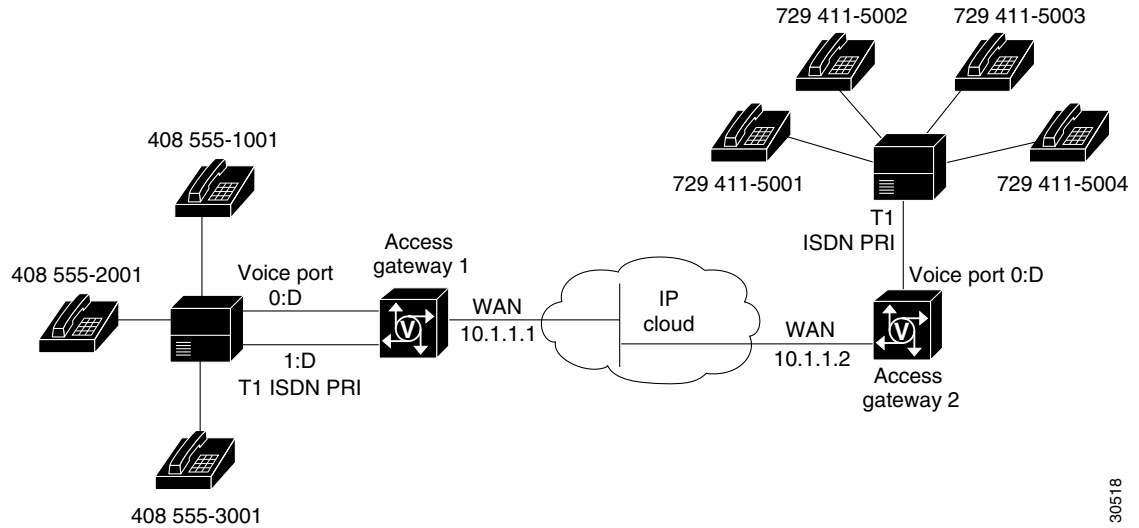

Figure B-3 VoIP Gateway Used as a Central Site Telephony Termination Facility



Gatekeepers

Gatekeepers are optional nodes that manage other nodes in an H.323 network. Other nodes communicate with the gatekeeper using the Registration, Admission, and Status (RAS) protocol.

These nodes register with a gatekeeper on startup. When they wish to communicate with another endpoint, they request admission to the call, using a symbolic alias for the endpoint name, such as an E.164 address or an e-mail ID. If the gatekeeper decides that the call can proceed, it returns a destination

IP address to the originating endpoint. This IP address can be the actual address of the target endpoint, or it can be an intermediate address. Finally, a gatekeeper and its registered endpoints exchange status information.

Gatekeeper Zones

H.323 endpoints are grouped together in zones. Each zone has one gatekeeper that manages all of the endpoints in the zone. A zone is an administrative convenience similar to a DNS domain.

H.323 Terminals

An H.323 terminal is an endpoint in the LAN that provides for real-time, two-way communications with another H.323 terminal or gateway. This communication consists of control, indications, audio, moving color video pictures, or data between the two terminals. A terminal may provide audio only; audio and data; audio and video; or audio, data, and video.

Reference Documentation

See the following publications for detailed information:

- *Service Provider Features for Voice over IP*
- *Voice over IP for the Cisco 5300*
- *Voice over IP for the Cisco 2600/3600 Series*



INDEX

A

access gateway **1-2, 2-3, 2-11**
 configuration **4-10**
 installation **4-10**
 management **1-8**

accounting **1-8**

alarms **1-7**

A-link with Cisco SLT connection **2-3**

A-link with Cisco SLT drop and insert connection **2-4**

applications
 packet telephony and data wholesale services **1-11**
 PSTN voice and fax traffic offload **1-11**
 two-stage-dial toll bypass **1-10**

architecture **1-2**

automatic failover **3-2**

B

benefits **1-4**

C

call detail records **3-3**

call flow **B-2**

CDR **3-3**

Cisco 3650 **1-2**

Cisco Catalyst switch **1-2, 4-9**

Cisco IOS **2-10**

Cisco MGC **1-2**

Cisco SC2200 **1-4**

Cisco SLT **1-2, 1-9, 2-3, 2-11**
 configuration **4-8**

 installation **4-3**

Cisco SLT management **1-9**

CMM **1-7, 3-4, 4-6**

components **2-7**

configuration **2-1**
 access gateway **4-10**
 Cisco SLT **4-8**
 continuous service **2-2**
 gatekeeper **4-11**
 signaling controller **4-6**
 simplex **2-1**
 software **4-5**

connection
 A-link with Cisco SLT **2-3**
 A-link with Cisco SLTdrop and insert **2-4**
 F-link with Cisco SLT **2-4**
 F-link with Cisco SLTdrop and insert **2-4**
 options **2-3**
 TDM cross-connect **2-4**

continuity testing **4-10**

continuous service configuration **2-2**

control network **2-5**

control signaling network **2-12**

COT **4-10**

customer-provided equipment guidelines **2-5**

D

data wholesale services **1-11**

disk mirroring **3-3**

document
 latest version **4-13**

documentation

conventions used in **x**
 meaning of cautions used in **xi**
 meaning of notes in **xi**

DPP **1-7**

drop and insert **2-4**

E

engineering considerations **2-7**

F

failover **3-2, 4-11**

fault-tolerant **3-3**

features **1-4**

F-link with Cisco SLT connection **2-4**

F-link with Cisco SLT drop and insert connection **2-4**

G

gatekeeper

configuration **4-11**

description **B-4**

installation **4-11**

gateway

access gateway **2-3, 2-11, 4-10**

access gateway, gatekeeper **1-2**

description **B-3**

management **1-8**

media gateway **1-2**

H

hardware installation **4-2, 4-10**

I

implementation **4-1**

information, additional **4-14**

installation **4-2**

access gateway **4-10**

Cisco SLT **4-3**

gatekeeper **4-11**

network access hardware **4-4**

signaling controller **4-3**

software **4-5**

IP connectivity with LAN **2-6**

IP connectivity with WAN **2-6**

IP control network combinations **2-6**

L

LAN connectivity **2-6**

LAN switch **1-2, 2-12**

configuration

configuration

LAN switch **4-9**

latest version of guide **4-13**

M

maintenance **4-11**

manual control **3-4**

media gateway controller **1-2**

messages **3-2**

MML **3-2, 3-4, 4-6**

N

network access hardware

installation **4-4**

O

online copy of guide **4-13**

operation **4-11**

P

packet telephony and data wholesale services **1-11**
 packet telephony services **1-11**
 performance **1-6**
 point codes **A-2**
 procedures **4-11**
 PSTN voice and fax traffic offload **1-11**
 PXE **3-2**

R

redundancy **1-6, 3-1, 3-2, 3-3**
 redundant link manager **4-10**
 reliability **1-6**
 RLM **4-10**

S

scalability **1-6**
 SC host **1-2, 1-4, 2-8**
 features **2-9**
 management **1-7**
 SC node **1-4, 2-8**
 SC zone **1-4**
 Session Manager **1-9, 3-1**
 signaling
 common channel interface **1-1**
 control network **2-5**
 management **1-7**
 signaling controller **1-2, 1-4, 2-3**
 signaling link terminal **1-2, 2-11**
 SS7 **1-1**
 signaling controller **1-4, 2-3, 2-8, 3-4**
 accounting **1-8**
 alarms **1-7**
 configuration **4-6**
 installation **4-3**
 management **1-7**
 software configuration **4-5**
 software installation **4-5**
 signaling control network **2-5**
 customer-provided equipment guidelines **2-5**
 engineering considerations **2-7**
 IP connectivity with LAN **2-6**
 IP connectivity with WAN **2-6**
 IP control network combinations **2-6**
 signaling link terminal
 configuration **4-8**
 installation **4-3**
 Signaling System 7 **A-1**
 defined **1-1**
 simplex configuration **2-1**
 software **2-10**
 configuration **4-5**
 installation **4-5**
 software configuration **3-4, 4-10**
 solution
 accounting **1-8**
 applications **1-10**
 architecture **1-2**
 benefits **1-4**
 Cisco SLT management **1-9**
 components **2-7**
 configurations **2-1**
 description **1-1**
 features **1-4**
 gateway management **1-8**
 hardware installation **4-2**
 implementation **4-1**
 management **1-7**
 packet telephony and data wholesale services **1-11**
 PSTN voice and fax traffic offload **1-11**
 scalability and performance **1-6**
 software **2-10**
 system redundancy **1-6**
 two-stage-dial toll bypass **1-10**
 SS7 **A-1**

point codes **A-2**
system messages **3-2**

T

TDM cross-connect **2-4**
toll bypass **1-10**
traffic offload **1-11**
two-stage-dial toll bypass **1-10**

U

unattended operation **3-1, 3-2**
UniverCD, ordering **4-14**
URL locations, Cisco web sites **4-13**

V

VoIP **4-11**
VoIP, QoS **B-1**

W

WAN connectivity **2-6**
web sites, Cisco **4-13**