



Gigabit Ethernet High-Speed WAN Interface Cards

Revised: 6/7/07, OL-12852-01

Overview

This document describes Cisco Gigabit Ethernet high-speed WAN interface cards (HWICs) and how to connect a Cisco Gigabit Ethernet HWIC to the network, and contains the following sections:

- [Cisco Gigabit Ethernet High-Speed WAN Interface Cards, page 1](#)
- [Installing Small Form-Factor Pluggable Modules into Cisco Gigabit Ethernet High-Speed WAN Interface Cards, page 4](#)
- [Removing Small Form-Factor Pluggable Modules from Cisco Gigabit Ethernet High-Speed WAN Interface Cards, page 5](#)
- [Cabling for Small Form-Factor Pluggable Modules, page 6](#)
- [Connecting Cisco Gigabit Ethernet High-Speed WAN Interface Cards to the Network, page 7](#)
- [Related Documentation, page 8](#)
- [Obtaining Documentation, Obtaining Support, and Security Guidelines, page 9](#)

For an overview of Cisco interface cards used for Cisco access routers see the [Cisco Interface Cards for Cisco Access Routers](#) document.

Cisco Gigabit Ethernet High-Speed WAN Interface Cards

The Cisco Gigabit Ethernet high-speed WAN interface card (HWIC-1GE-SFP) is a high-speed interface card providing copper and optical Gigabit Ethernet connectivity for Cisco modular access routers.

The Cisco Gigabit Ethernet high-speed WAN interface card provides copper and optical Gigabit Ethernet connectivity through a small form-factor pluggable module (SFP), which is inserted into the interface card. (See the [“Installing Small Form-Factor Pluggable Modules into Cisco Gigabit Ethernet High-Speed WAN Interface Cards”](#) section on page 4.)

SFPs can be installed or removed without powering down the router and interface card.

**Caution**

To comply with the Telcordia GR-1089 NEBS standard for electromagnetic compatibility and safety, connect the Gigabit Ethernet high-speed WAN interface card (HWIC-1GE-SFP) only to intra-building or non-exposed wiring or cabling. The intrabuilding cable must be shielded and the shield must be grounded at both ends.

**Note**

The Cisco Gigabit Ethernet high-speed WAN interface card itself is not hot-swappable. Removal or insertion of the Cisco Gigabit Ethernet high-speed WAN interface card requires powering down the router.

The Cisco Gigabit Ethernet high-speed WAN interface card supports the SFPs shown in [Table 34](#).

Table 34 *SFPs Supported on the Cisco Gigabit Ethernet High-Speed WAN Interface Card (HWIC-1GE-SFP)*

GE SFP Transceiver Type	Cisco Part Number	Wavelength	Maximum Distance
1000BASE-T	GLC-T=	n/a	100 m
1000BASE-SX	GLC-SX-MM=	850 nm	500 m
1000BASE-LX/LH	GLC-LH-SM=	1310 nm	10 km
1000BASE-ZX	GLC-ZX-SM=	1550 nm	80 km
1000BASE-CWDM	CWDM-SFP-1470=	1470 nm	100 km
	CWDM-SFP-1490=	1490 nm	
	CWDM-SFP-1510=	1510 nm	
	CWDM-SFP-1530=	1530 nm	
	CWDM-SFP-1550=	1550 nm	
	CWDM-SFP-1570=	1570 nm	
	CWDM-SFP-1590=	1590 nm	
	CWDM-SFP-1610=	1610 nm	

**Note**

Only Cisco-certified SFPs are supported on the Cisco Gigabit Ethernet high-speed WAN interface card.

**Tip**

When switching from one type of SFP to another, connection problems, including connection failure, may result. Use the **show controller** command at the Cisco IOS command-line interface (CLI) to determine whether you are using an SFP certified by Cisco.

Different SFPs have different cabling requirements; see the [“Cabling for Small Form-Factor Pluggable Modules”](#) section on page 6 for more information on SFP cabling.

Laser Safety Guidelines

Optical SFPs use a small laser to generate the fiber-optic signal. Keep the optical transmit and receive ports covered whenever a cable is not connected to the port.

The interface card faceplate carries a Class 1 laser warning label. (See [Figure 115](#).)

Figure 115 Class 1 Laser Warning Label

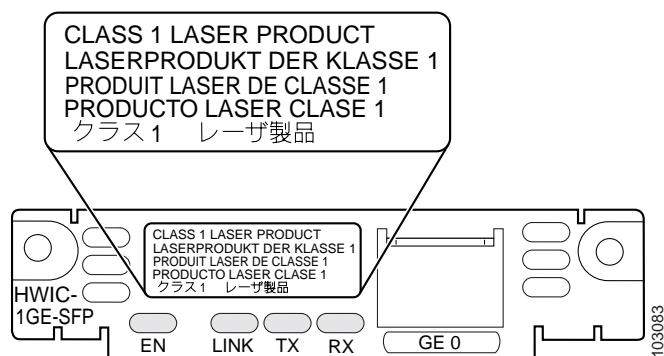

Because invisible laser radiation may be emitted from the aperture of the port when no fiber cable is connected, avoid exposure to laser radiation and do not stare into open apertures. Statement 125



Ultimate disposal of this product should be handled according to all national laws and regulations. Statement 1040

Cisco Gigabit Ethernet High-Speed WAN Interface Card LEDs

The Cisco Gigabit Ethernet high-speed WAN interface card uses LEDs to indicate card status and activity. (See [Figure 116](#).)

Figure 116 Cisco Gigabit Ethernet High-Speed WAN Interface Card Faceplate (HWIC-1GE-SFP)

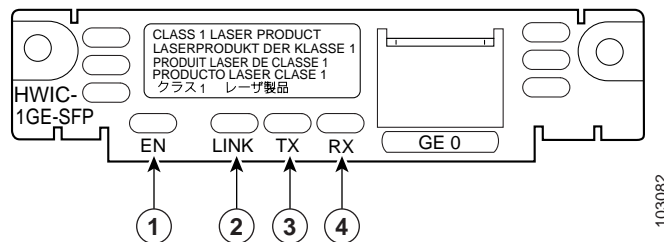

1	EN: When green, indicates that the interface card is available to the router.	2	LINK: When green, indicates that the connection is available to the router.
3	TX: When green, indicates that the interface is transmitting data to the network.	4	RX: When green, indicates that the interface is receiving data from the network.

Installing Small Form-Factor Pluggable Modules into Cisco Gigabit Ethernet High-Speed WAN Interface Cards

Small form-factor pluggable modules (SFPs) are hot-swappable Ethernet interfaces that can be installed directly into the Cisco Gigabit Ethernet high-speed WAN interface card. See [Table 34](#) for SFPs supported on the Cisco Gigabit Ethernet high-speed WAN interface card.

To install an SFP into the Cisco Gigabit Ethernet high-speed WAN interface card, perform the following steps:

- Step 1** Install the interface card in the router. (See [Chapter , “Installing Cisco Interface Cards in Cisco Access Routers.”](#))



Warning

Because invisible laser radiation may be emitted from the aperture of the port when no fiber cable is connected, avoid exposure to laser radiation and do not stare into open apertures. Statement 125

- Step 2** Slide the SFP into the housing on the interface card until it is locked into position. (See [Figure 117.](#)) The SFP is designed to prevent improper insertion.



Tip

If the SFP uses a bale-clasp latch (see [Figure 117](#) and [Figure 118](#)), the bale-clasp handle should be on top of the SFP in the closed position for proper seating of the SFP module.

Figure 117 Installing an SFP on the Cisco Gigabit Ethernet High-Speed WAN Interface Card

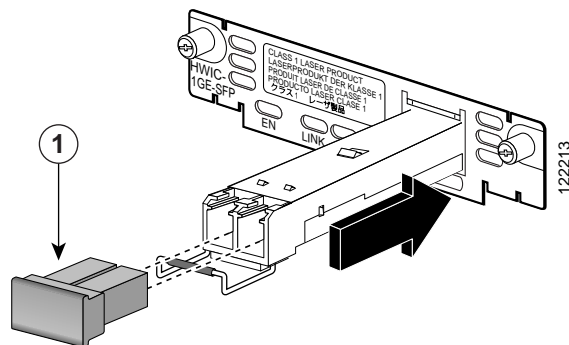

1 Optical port plug



Caution

Do not remove the optical port plugs used on the SFP until you are ready to connect cabling to the interface card.



Caution

To comply with the Telcordia GR-1089 NEBS standard for electromagnetic compatibility and safety, connect the Gigabit Ethernet high-speed WAN interface card (HWIC-1GE-SFP) only to intra-building or non-exposed wiring or cabling. The intrabuilding cable must be shielded and the shield must be grounded at both ends.

- Step 3** Connect the interface card to the network. (See the “[Connecting Cisco Gigabit Ethernet High-Speed WAN Interface Cards to the Network](#)” section on page 7.)

Removing Small Form-Factor Pluggable Modules from Cisco Gigabit Ethernet High-Speed WAN Interface Cards

This section describes a generic removal procedure. Small form-factor pluggable modules (SFPs) use various latch designs (see [Figure 118](#)) to secure the module in the SFP port.



Note

Latch designs are not linked to SFP model or technology type; for information on the SFP technology type and model, see the label on the top or side of the SFP.

Removing SFPs from Cisco Gigabit Ethernet High-Speed WAN Interface Cards

To remove an SFP from a Cisco Gigabit Ethernet high-speed WAN interface card, perform the following steps:

- Step 1** Disconnect all cables from the SFP.



Warning

Because invisible laser radiation may be emitted from the aperture of the port when no fiber cable is connected, avoid exposure to laser radiation and do not stare into open apertures. Statement 125



Caution

The latching mechanism used on many SFPs locks the SFP into place whenever cables are connected. Do not pull on the cabling in an attempt to remove the SFP.

- Step 2** Disconnect the SFP latch (see [Figure 118](#)).

Figure 118 Disconnecting SFP Latch Mechanisms

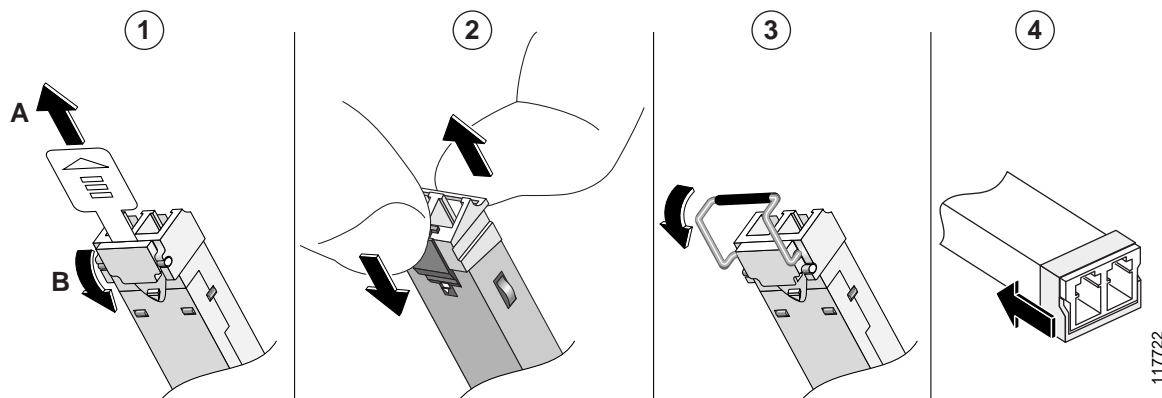

1	Sliding latch	2	Swing and slide latch
3	Bale-clasp latch	4	Plastic collar latch

**Tip**

Use a pen, screwdriver, or other small, straight tool to gently release the bale-clasp handle if you cannot reach it with your fingers.

Step 3 Grasp the SFP on both sides and remove it from the interface card.

Cabling for Small Form-Factor Pluggable Modules

Cisco Gigabit Ethernet high-speed WAN interface cards connect to the network through various supported small form-factor pluggable modules (SFPs). Cabling requirements vary by SFP. See the “[Cabling for Small Form-Factor Pluggable Modules](#)” section on page 6.

For information on cabling requirements for various small form-factor pluggable modules (SFPs) supported by the Cisco Gigabit Ethernet high-speed WAN interface card, see [Table 35](#).

Table 35 *Cabling Requirements for Gigabit Ethernet Small Form-Factor Pluggable Modules*

GE SFP Transceiver Type	Cisco Part Number	Maximum Distance	Cabling Required	Connector Type
1000BASE-T	GLC-T=	100 m	Category 5, 5e, 6	RJ-45
1000BASE-SX	GLC-SX-MM=	300 m	62.5/125 micrometer MMF ¹	LC connector
		500 m	50/125 micrometer MMF	
1000BASE-LX/LH	GLC-LH-SM=	550 m	50/125 micrometer or 62.5/125 micrometer MMF	LC connector
		10 km	9/125 micrometer SMF ²	
1000BASE-ZX	GLC-ZX-SM=	80 km	9/125 micrometer SMF	LC connector
1000BASE-CWDM	CWDM-SFP-1470= CWDM-SFP-1490= CWDM-SFP-1510= CWDM-SFP-1530= CWDM-SFP-1550= CWDM-SFP-1590= CWDM-SFP-1610=	100 km	9/125 micrometer SMF	LC connector

1. MMF = multimode fiber

2. SMF = singlemode fiber

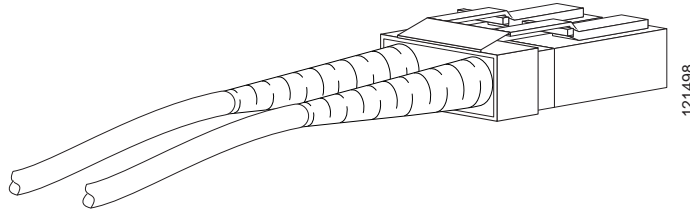
Figure 119 LC Connector**Note**

Coarse wavelength-division multiplexing (CWDM) SFP transceivers are color-coded based on wavelength: gray (1470), violet (1490), blue (1510), green (1530), yellow (1550), orange (1570), red (1590), and brown (1610).

Cisco Gigabit Ethernet high-speed WAN interface cards are designed for use in the following network design scenarios:

- In metropolitan-area network (MAN) backbones for low-cost, high-speed, and long-distance connectivity
- In multiprotocol WAN gateway routers for LANs
- In same-building or same-campus wiring closets to achieve high-speed connectivity for high-demand network segments

**Tip**

For more information on possible network configurations using the Cisco Gigabit Ethernet high-speed WAN interface card, see Cisco product documentation.

Connecting Cisco Gigabit Ethernet High-Speed WAN Interface Cards to the Network

To connect the Cisco Gigabit Ethernet high-speed WAN interface card to the network, perform the following steps:

Step 1 Confirm successful insertion of the SFP.

**Warning**

Because invisible laser radiation may be emitted from the aperture of the port when no fiber cable is connected, avoid exposure to laser radiation and do not stare into open apertures. Statement 125

Step 2 Confirm that the router is powered down.

Step 3 Remove optical port plugs from the installed SFP.

Step 4 Use the appropriate cable (see [Table 35](#)) to connect to the installed SFP.

**Note**

For short distances or loopbacks, network installations using 1000BASE-CWDM and 1000BASE-ZX SFPs may require 15-dBm attenuators to avoid over-powering the connection. Calculate the power budget for the connection to determine which attenuator to use.

- Step 5** For network installations that use 1000BASE-CWDM SFPs, connect the SFP to a Cisco CWDM optical add-drop multiplexing (OADM) interface card. (See [Figure 120](#).) For information on the Cisco CWDM OADM, see the [Installation Note for the Cisco CWDM Passive Optical System](#) document.

Figure 120 Using a Cisco CWDM OADM Card to Connect the Cisco Gigabit Ethernet High-Speed WAN Interface Card to the Network

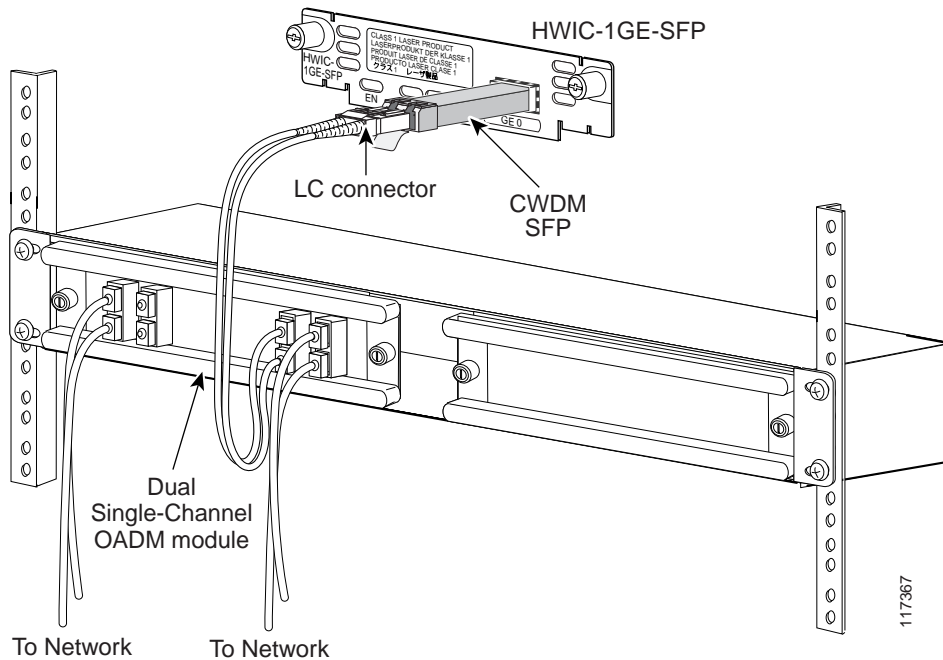

- Step 6** Connect the other end of the appropriate cable (see [Table 35](#)) to your network.
- Step 7** Continue router startup and configuration tasks.

Related Documentation

Related documentation is available on Cisco.com or on the Product Documentation DVD. For more information, see the “[Obtaining Documentation, Obtaining Support, and Security Guidelines](#)” section on [page 9](#).

- [Cisco Gigabit Ethernet High-Speed WAN Interface Card for Cisco 2800 and 3800 Series Routers](#), data sheet
- [Cisco Gigabit Ethernet High-Speed WAN Interface Card](#), Q&A
- [Cisco Network Modules and Interface Cards Regulatory Compliance and Safety Information](#)
- “[Configuring LAN Interfaces](#)” chapter of the *Cisco IOS Interface Configuration Guide*, Release 12.2

Obtaining Documentation, Obtaining Support, and Security Guidelines

For information on obtaining documentation, obtaining support, providing documentation feedback, security guidelines, and also recommended aliases and general Cisco documents, see the monthly *What's New in Cisco Product Documentation*, which also lists all new and revised Cisco technical documentation, at:

<http://www.cisco.com/en/US/docs/general/whatsnew/whatsnew.html>

CCVP, the Cisco logo, and Welcome to the Human Network are trademarks of Cisco Systems, Inc.; Changing the Way We Work, Live, Play, and Learn is a service mark of Cisco Systems, Inc.; and Access Registrar, Aironet, Catalyst, CCDA, CCDP, CCIE, CCIP, CCNA, CCNP, CCSP, Cisco, the Cisco Certified Internetwork Expert logo, Cisco IOS, Cisco Press, Cisco Systems, Cisco Systems Capital, the Cisco Systems logo, Cisco Unity, Enterprise/Solver, EtherChannel, EtherFast, EtherSwitch, Fast Step, Follow Me Browsing, FormShare, GigaDrive, HomeLink, Internet Quotient, IOS, iPhone, IP/TV, iQ Expertise, the iQ logo, iQ Net Readiness Scorecard, iQuick Study, LightStream, Linksys, MeetingPlace, MGX, Networkers, Networking Academy, Network Registrar, PIX, ProConnect, ScriptShare, SMARTnet, StackWise, The Fastest Way to Increase Your Internet Quotient, and TransPath are registered trademarks of Cisco Systems, Inc. and/or its affiliates in the United States and certain other countries.

All other trademarks mentioned in this document or Website are the property of their respective owners. The use of the word partner does not imply a partnership relationship between Cisco and any other company. (0711R)

Any Internet Protocol (IP) addresses used in this document are not intended to be actual addresses. Any examples, command display output, and figures included in the document are shown for illustrative purposes only. Any use of actual IP addresses in illustrative content is unintentional and coincidental.

© 2007 Cisco Systems, Inc. All rights reserved.

