



R2 Signaling Examples

This chapter provides examples of R2 signaling that use the following call control elements:

- Impulse rules
- Outputse rules
- Host commands and reports

Two examples discuss R2 digit collections on incoming trunks (calls coming into the VCO system); a third example describes R2 digit outputse on outgoing trunks (calls originating at the VCO system). Each example begins with a brief explanation of the scenario, followed by a graphic representation of the call flow. These diagrams illustrate system processing and information flow between the VCO system and host, and between the VCO system and connected equipment (network registers). Direction of the information flow is indicated by arrows under the message data.

Using MFCR2 Outputse Rule Tokens

MFCR2 outputse rule tokens include the following tones:

- Forward tones—These tones fall into Groups I and II. All Group I and II tones use the ITU-T R2 forward group tone frequencies. Most of the tones in Group I are used for addressing and identification. Group II tones give information about the origin of the call. Group II tones are also sent by an outgoing MFCR2 service circuits in response to one of the following backward signals:
 - Change over to the reception of Group B signals.
 - Send calling party's category.
- Backward tones—These tones fall into Groups A, B, and C. The Group A tones acknowledge Group I forward signals. Under certain conditions, Group A tones also acknowledge Group II tones. Group B tones convey the following information to an outgoing MFCR2 register:
 - The condition of the switch equipment in the incoming exchange.
 - The condition of the called subscriber's line.

Group B tones are also sent in response to Group II tones once a changeover to the reception of a Group B signal request is successfully completed.

These tones correspond to Category and Fields in the following manner:

- OP FIELD [xx] is populated with dialed digits. The first digit in OP FIELD [xx] is always sent first. Additional digits in OP FIELD [xx] are sent in response to an A-1 tone. The Group I-15 tone is sent forward if OP FIELD [xx] is exhausted. Transmission starts again from the top of OP FIELD [xx] in response to an A-9 tone.

- IP ANI [xx] is populated by the calling party's A number. The first digit in IP ANI [xx] is sent in response to the second A-5 backward tone.
- OP CAT [xx] data is the Group II signal, which indicates the calling party's service class. The single digit in OP CAT [xx] is sent in response to an A-5 backward tone. The Group B backward tone is sent in response to the Group II signal and completes the MFCR2 signaling dialogue.

The Group B tones, as well as tone A-6, indicate a terminal status and complete the register signaling dialogue. Pulsed transmission of A-4 indicates a busy state. Receiving tones B-2, B-3, B-4, B-5, B-8, or A-4 cause the system to fail the call attempt.

Example #1—Incoming Call Using Inpulse Rules

Example #1 illustrates a simple R2 digit collection scenario after an incoming seize on the E1 circuit at port address \$00 61. A Korea specific inpulse rule is executed to perform R2 digit collection on this circuit.

The inpulse rule performs the following general tasks:

- Collects an unspecified number of called party number digits and stores them in Field 1. A-1 (send next digit) signals prompt the network register for each new digit. When an I-15 digit is received, the system sends an A-5 (send calling party digits).
- Collects the Group II signal and calling party number and stores it in the ANI number field. C-1 signals (send calling party's number) prompt the network register for each new digit. After the digits are received, the system sends an A-3 (send Group II) digit.
- Collects the Group II signal (1 digit) and stores it in Field 3. After the Group II signal is collected, the system sends a B-6 (set up speech conditions) digit.

At the end of this example, the system establishes speech conditions with the connected equipment (network register) and generates an Inpulse Rule Complete (\$DD) report to the host. The processing flow for this example is shown in Figure 4-1 to Figure 4-3. In this example, it is assumed that the Korea specific inpulse rule for the incoming circuit is defined as inpulse rule #1 (shown below).

Inpulse Rule #1

- REP EACH
- MFCR2
- END CHAR1 5
- CLR CHAR1 1
- DIGITS 0
- IP FIELD 1
- END CHAR1 3
- CLR CHAR1 1
- IP ANI 0
- END CHAR1 1
- CLR CHAR1 1
- DIGITS 1
- IP FIELD 3

Refer to the *Cisco VCO/4K System Administrator's Guide* for more information about specific MFCR2 inpulse rule tokens.

Figure 4-1 Processing Flow for Example #1, Part 1 of 3

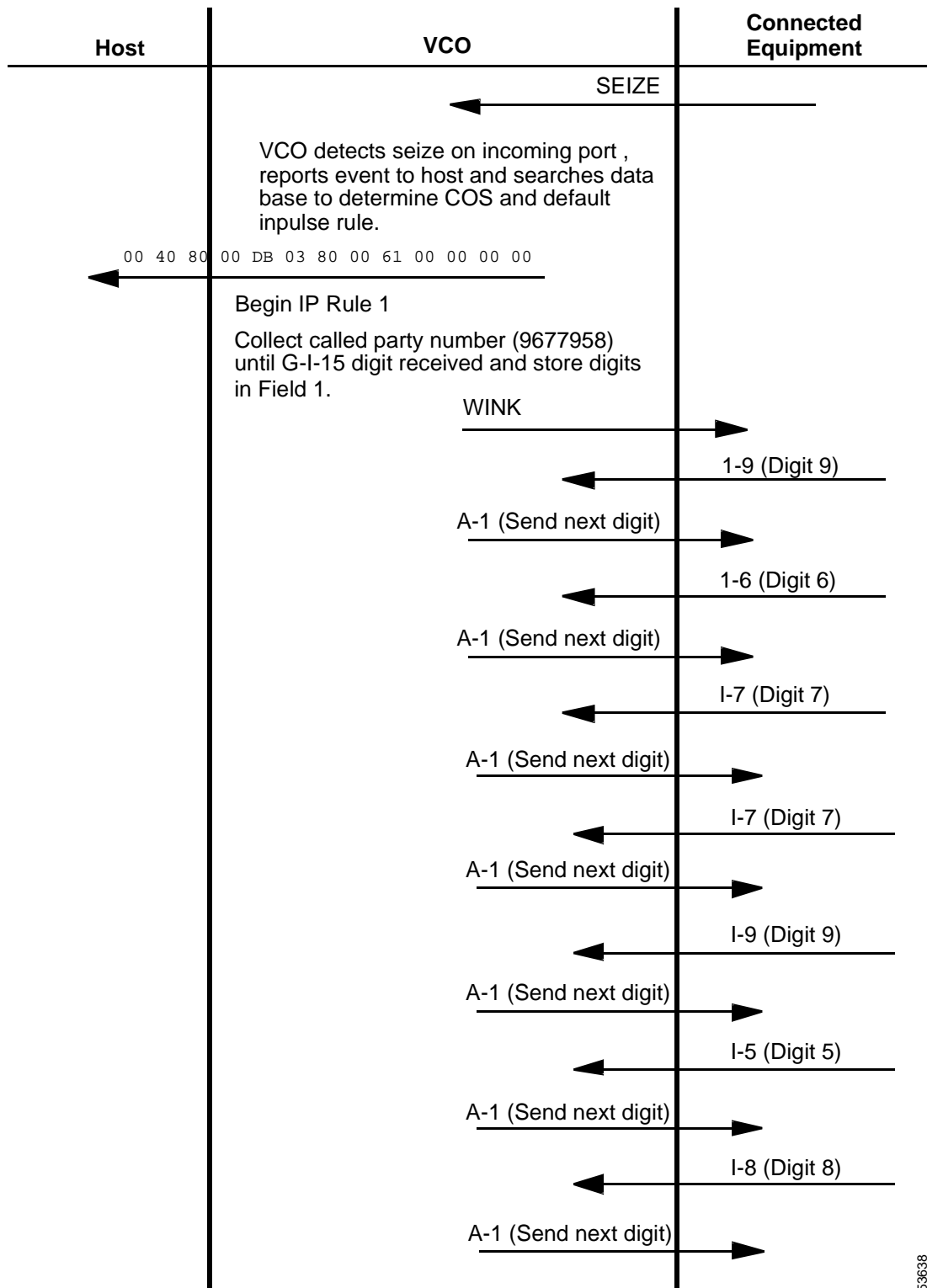

53638

Figure 4-2 Processing Flow for Example #1, Part 2 of 3

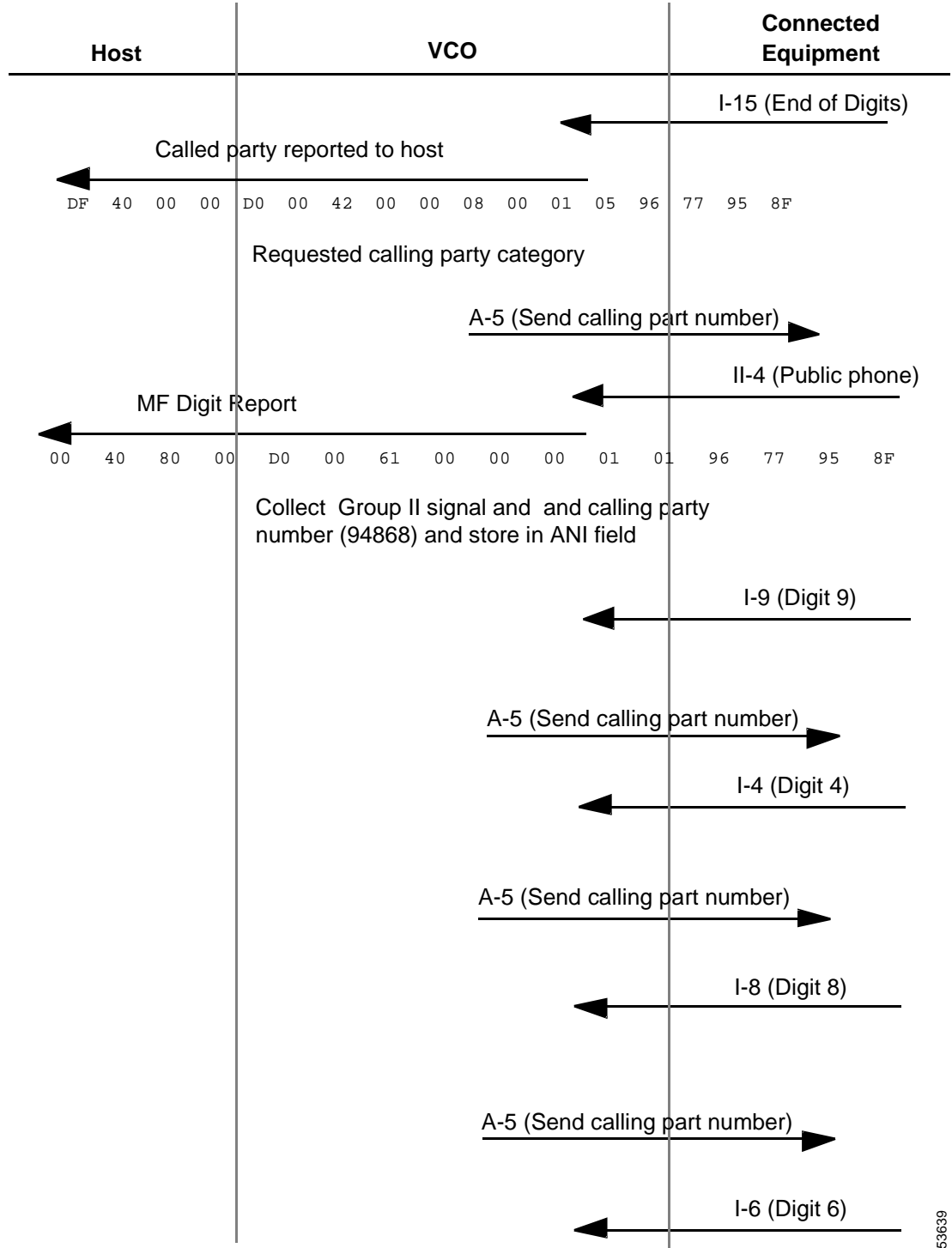

53639

Figure 4-3 Processing Flow for Example #1, Part 3 of 3

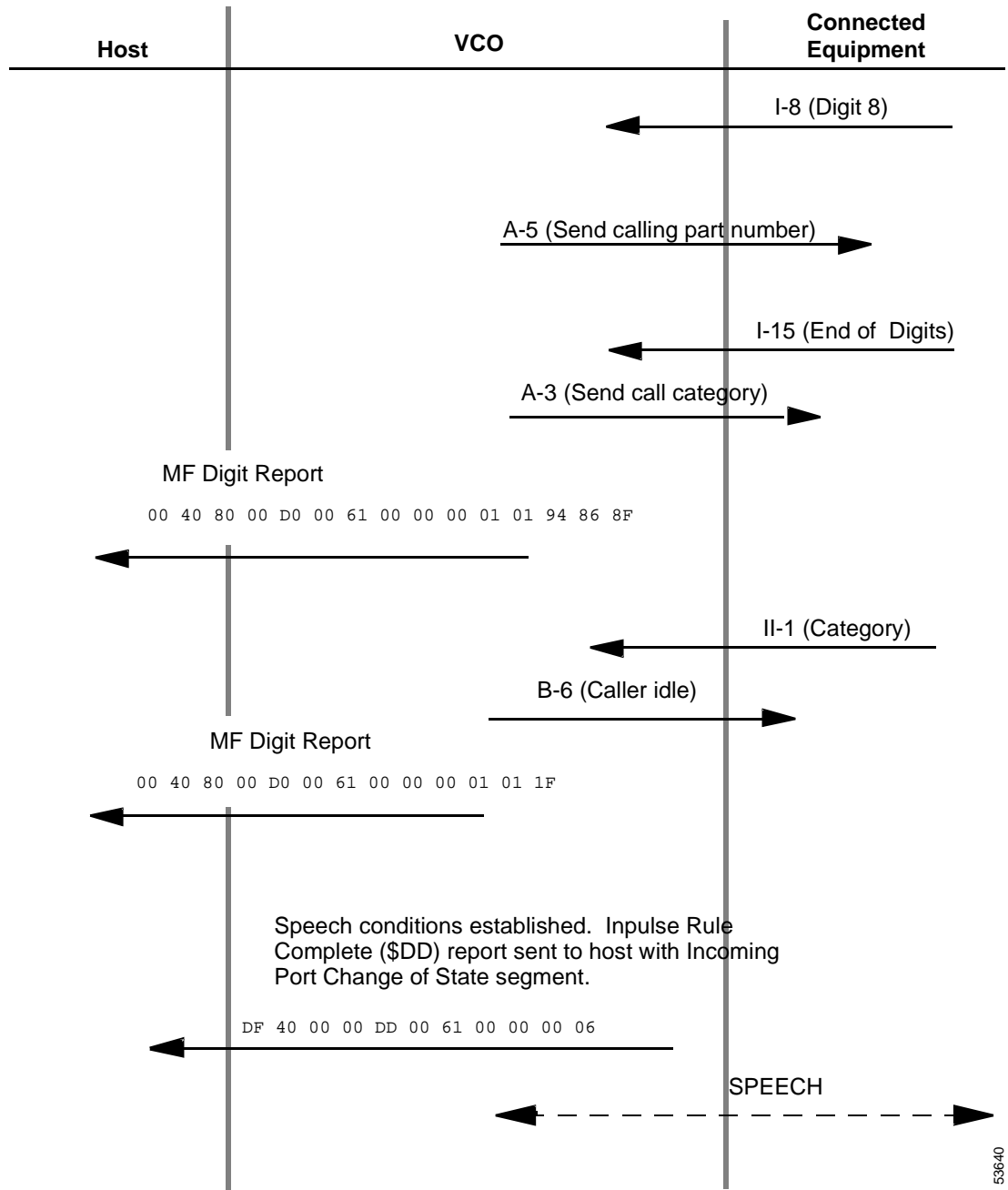

53640

Example #2—Incoming Call Using \$68 Host Command

Example #2 also illustrates a simple R2 digit collection scenario on an incoming E1 circuit (port address \$00 61). However, all R2 digit collections in this scenario are initiated by host command; no impulse rule processing is used. Three MF Collection Control (\$68) commands perform the following actions:

- Collect an unspecified number of called party number digits until I-15 digit is received, then send an A-5 to get the Group II signal.
- Collect the Group II signal followed by an unspecified number of calling party digits until the I-15 digit is received by sending back A-1, then send back A-3 to get the Group II signal tone.
- Collect the Group II signal tone, then send a B-6 (set up speech conditions) digit.

An MF Digit (\$D0) report reports each digit collection to the host.

At the end of this example, the system establishes speech conditions with the connected equipment (network register). The processing flow for this example is shown in Figure 4-4 to Figure 4-6.

Refer to the *Cisco VCO/4K Standard Programming Reference* and the *Cisco VCO/4K Extended Programming Reference* for more information about the \$68 command and the \$D0 report.

Figure 4-4 Processing Flow for Example #2, Part 1 of 3

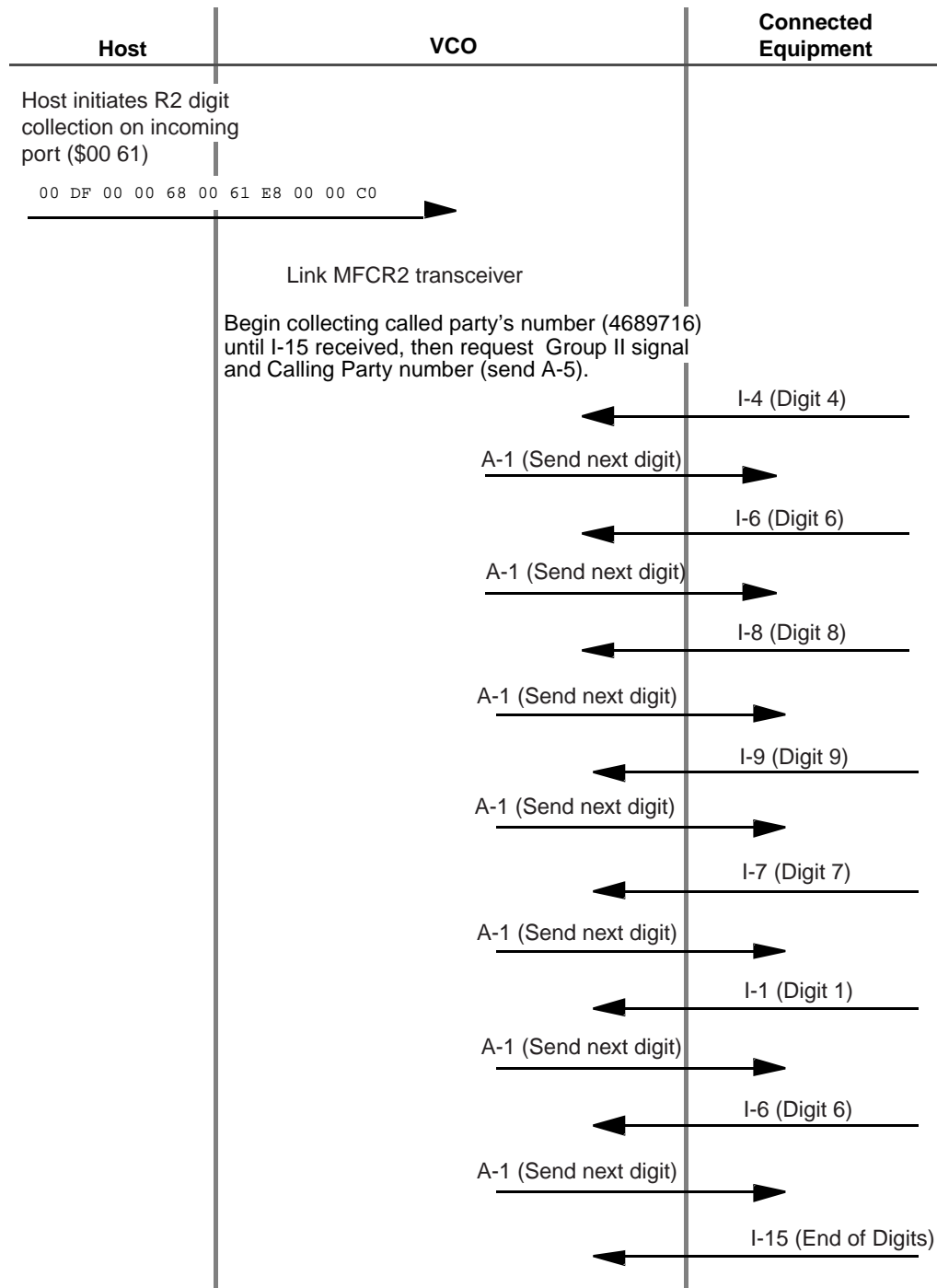

53641

Figure 4-5 Processing Flow for Example #2, Part 2 of 3

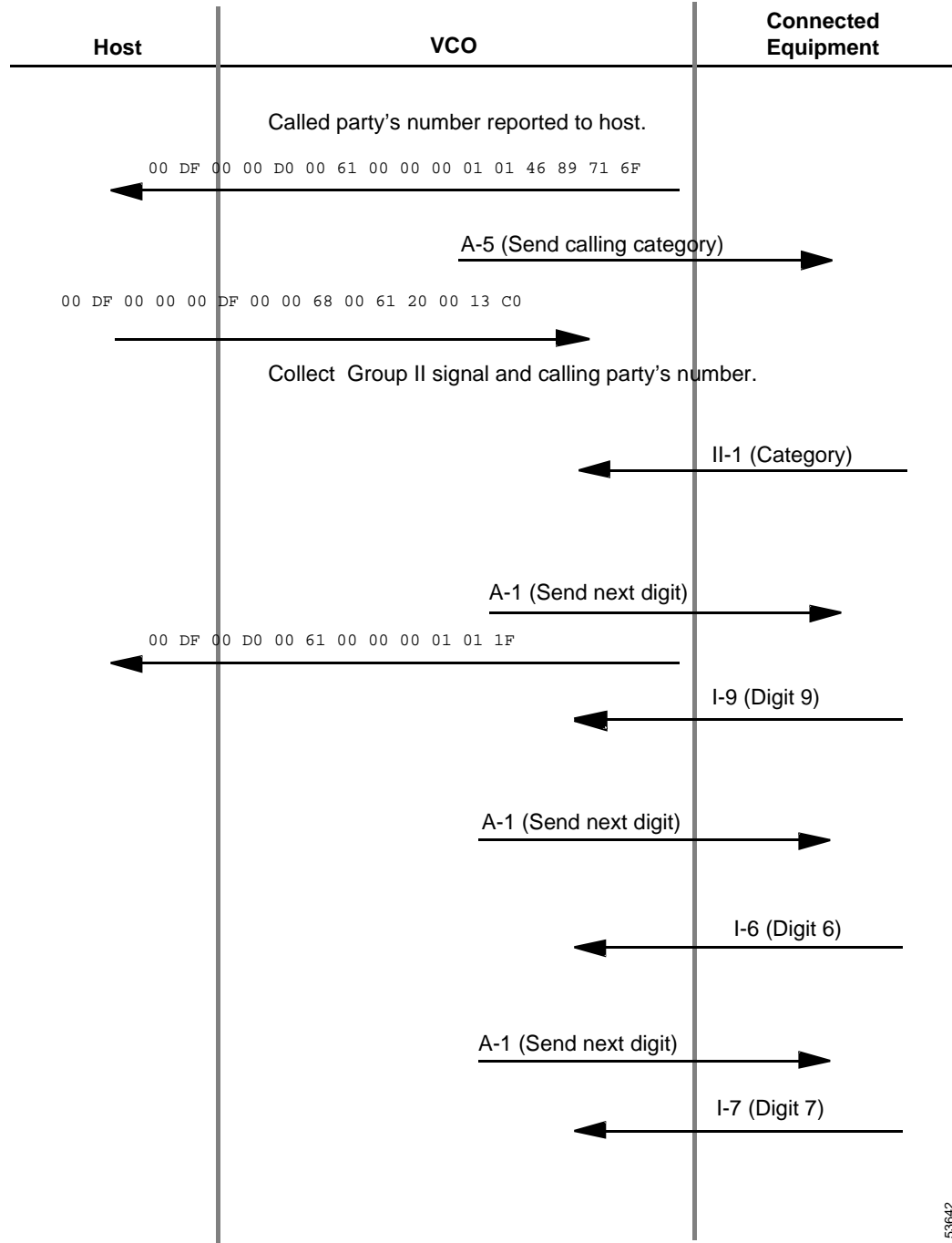

53642

Figure 4-6 Processing Flow for Example #2, Part 3 of 3

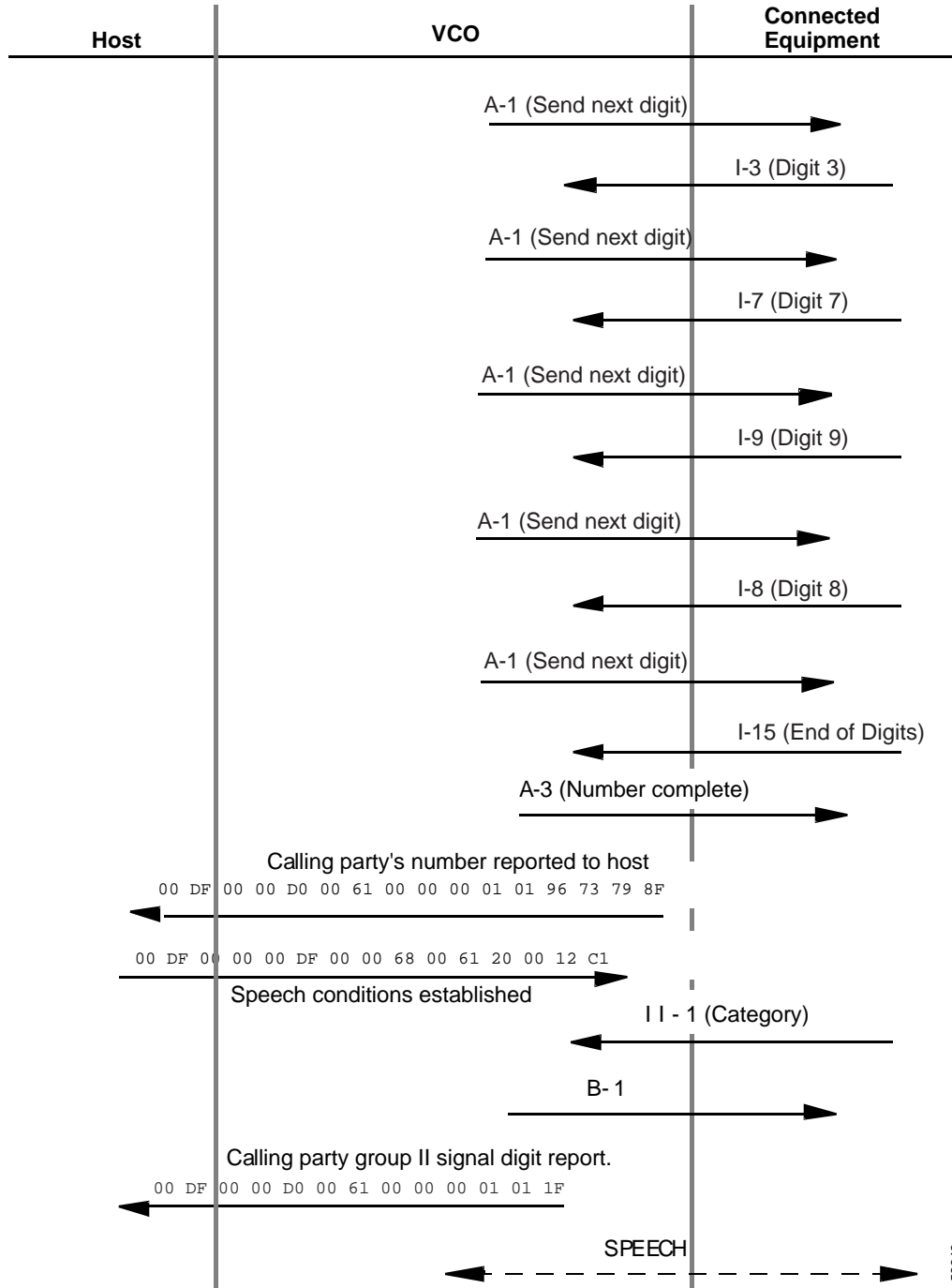

53643

Example #3—Outgoing Call

Example #3 describes R2 digit outpulsing on an E1 circuit at port address \$00 40. This scenario involves both host command and outpulse rule processing. The host initiates the outpulsing using an Outgoing Port Control (\$69) command that populates the digit fields and specifies the outpulse rule to execute (refer to the *Cisco VCO/4K Standard Programming Reference* or the *Cisco VCO/4K Extended Programming Reference* for a command description).

The outpulse rule performs the following actions:

- Seizes out on the E1 trunk at port address \$00 40 and waits for a wink signal (executing the WAIT SUP W preconfigured answer supervision template documented in the *Cisco VCO/4K System Administrator's Guide*).
- Outpulses five digits of the called party number (stored in Field 1) after wink signal is detected. The system responds to A-1 (send next digit) signals that request each new digit.
- Outpulses the Group II signal and calling party number stored in the ANI field when an A-6 digit is received.
- Outpulses the Group II signal digit specified in the rules OP CAT token in response to an A-3.

This rule is shown below.

Outpulse Rule #1

- REP END
- SEIZE
- WAIT SUP W
- OP MFCR2
- OP ANI
- OP CAT 1
- OP FIELD 1

At the end of this example, the system establishes speech conditions with the connected equipment (network register) and generates an Outgoing Port Change of State (\$DA) report to the host indicating the final backward digit. The processing flow for this example is shown in Figure 4-7 to Figure 4-9.

Refer to the *Cisco VCO/4K System Administrator's Guide* for more information about OP MFCR2, OP ANI, OP FIELD [xx], and OP CAT [xx] outpulse rule tokens.

Figure 4-7 Processing Flow for Example #3, Part 1 of 3

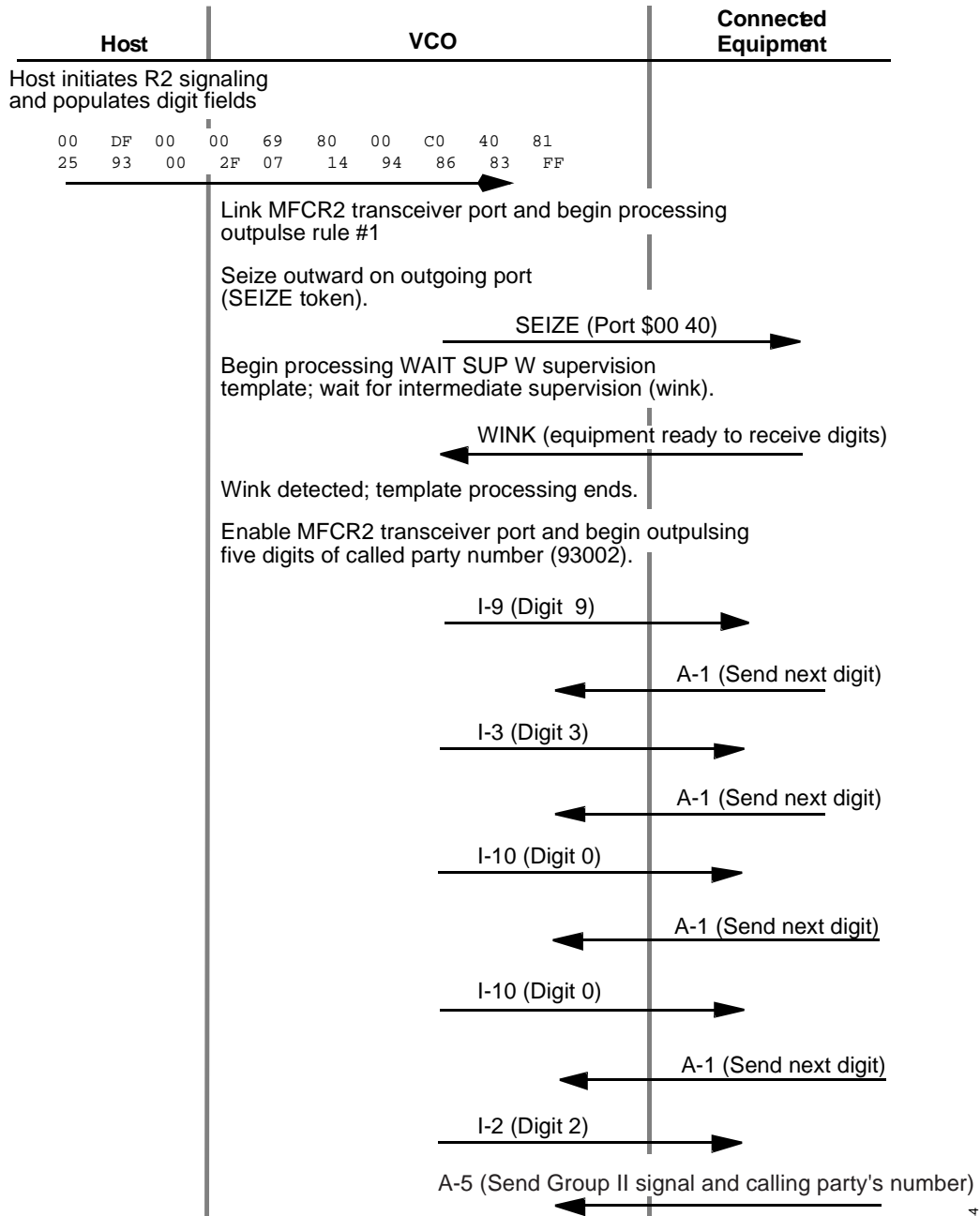

53644

Figure 4-8 Processing Flow for Example #3, Part 2 of 3

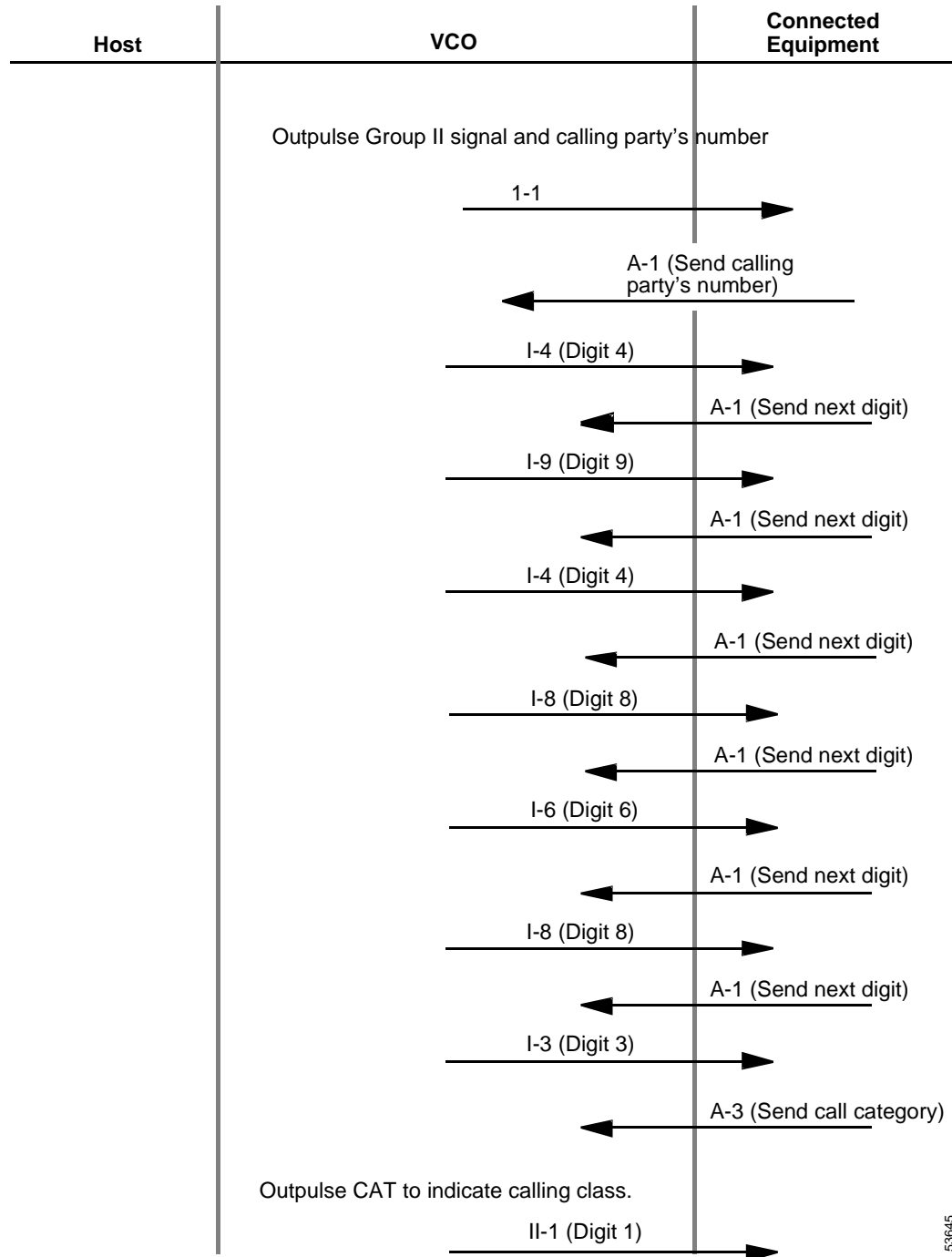

53645

Figure 4-9 Processing Flow for Example #3, Part 3 of 3

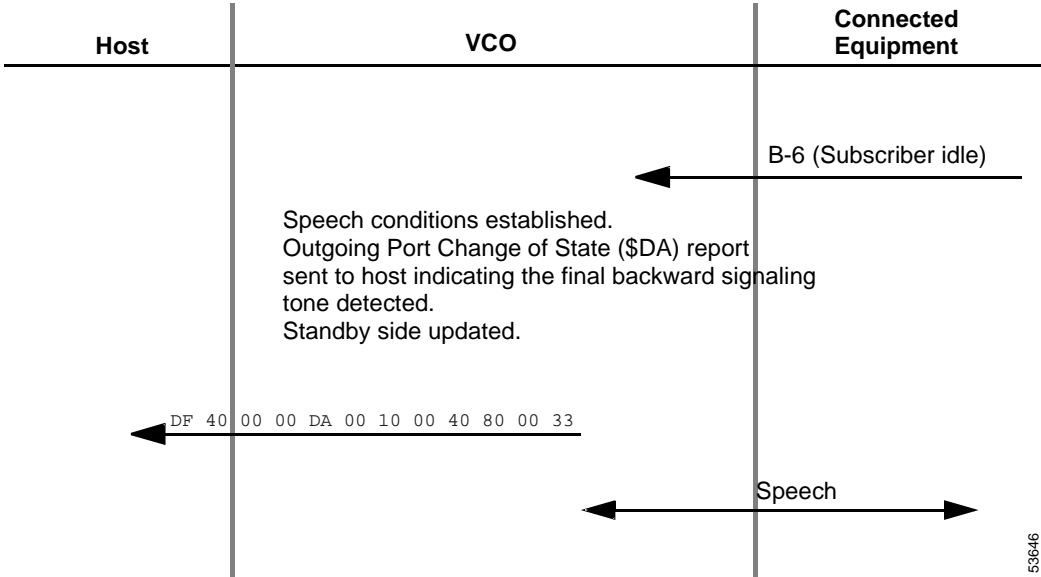

53646