

Reading LED Indicators

Most cards and appliques have light-emitting diode (LED) indicators that show, for example, the state of a port on an interface card or the mode (DTE or DCE) of a serial applique. These LEDs also can be used to troubleshoot and isolate a problem with the chassis and its components.

Typically, you will know a problem exists before you examine the LEDs, but should a problem require more investigation, the LEDs can help identify the problem.

The following card LEDs are included in this appendix:

- CSC-1R and CSC-2R
- CSC/3 and CSC/4
- CSC-C2CTR
- CSC-CCTL and CSC-CCTL2
- CSC-ENVM
- CSC-MCI and CSC-SCI
- CSC-MC+
- CSC-MEC and CSC-C2MEC
- CSC-R16M

The following applique LEDs are included in this appendix:

- Ethernet 10BaseT
- FDDI
- HSSI (APP-LHS)
- HD V.35 NRZI dual mode
- HD V.35 dual mode
- RS-232 DCE and DTE
- RS-232 Synchronous Data Link Control (SDLC) dual mode
- RS-449 DCE and DTE
- X.21 dual mode

Card LED Indicators

The following sections discuss reading and interpreting the LED indicators on interface and controller cards.

CSC-1R and CSC-2R Token Ring Cards: LED Indicators

Along the front edge of the CSC-1R (and CSC-2R) card are ten status LEDs: nine red and one green. The order of the LEDs is left to right when looking at the front edge of the card. (See Figure B-1.) Although only the CSC-1R is shown, both the CSC-1R and CSC-2R cards have the same LED configuration.

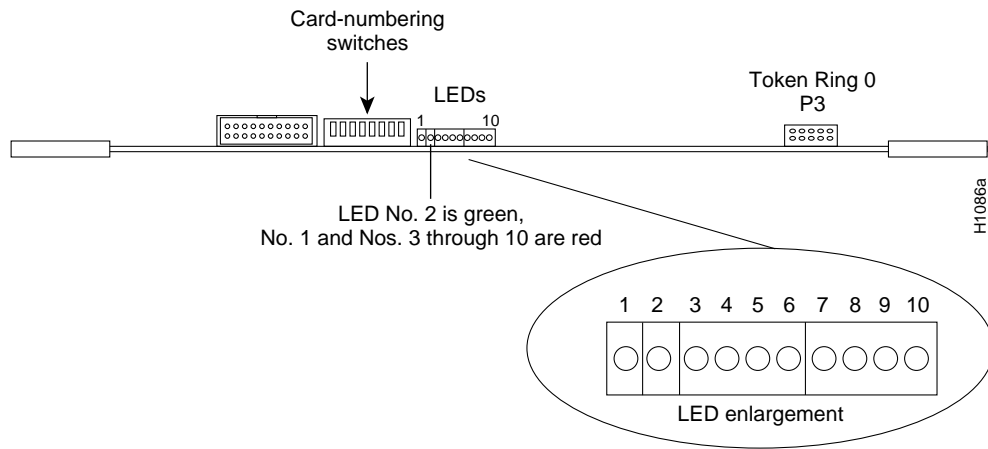

Figure B-1 CSC-1R and CSC-2R LED Indicators—Front-Edge View

The red LED on the far left end of the bank of LEDs is the Power-On LED (No. 1). The next LED is the green Processor LED (No. 2). The remaining eight LEDs (3 through 10) are all red. At system boot, these eight LEDs will change state to indicate that the CSC-2R card is being initialized. The seven initialization states of LEDs 3 through 10 are shown in Table B-1.

In the first initialization state, all eight status LEDs (3 through 10) are on. During the next four states, LEDs 7 through 10 will be on, while LEDs 6 through 3 consecutively will turn on then off. States 6 and 7 will indicate a successful initialization.

The first seven LED states display consecutively at system boot. If a problem occurs during this initialization, the state that the LEDs were in when the problem occurred will flash on and off.

When the port inserts onto the ring, LEDs 3 through 10 will flash a series of patterns too fast to see. Following this, LEDs 3 through 10 will strobe back and forth to indicate correct operation. The speed of this strobing is in inverse proportion to the volume of data traffic; the heavier the traffic, the slower the strobing and so forth. Either way, the strobing of these LEDs is the key indicator for the proper operation of the CSC-1R and CSC-2R Token Ring cards.

Table B-1 CSC-1R and CSC-2R Status LED States at System Boot

State	LEDs ¹							
	3	4	5	6	7	8	9	10
1	O	O	O	O	O	O	O	O
2	•	•	•	O	O	O	O	O
3	•	•	O	•	O	O	O	O
4	•	O	•	•	O	O	O	O
5	O	•	•	•	O	O	O	O
6	•	O	O	•	•	O	O	•
7	O	•	•	•	•	O	•	O

1. O = LED on. • = LED off.

CSC/3 and CSC/4 Processor Cards: LED Indicators

To the right of the configuration register, on the front edge of the processor card, are three LEDs. On the CSC/3, the left and center LEDs are red (see Figure B-2), while on the CSC/4, they are yellow (see Figure B-3). The third LED (far right) on each card is green. The LED on the left is a software-programmable status light; it lights (momentarily) during initialization, flashes to indicate an error, and remains off under normal operation. The middle LED is the processor halt light; it lights when the processor halts for any reason. This LED can flash at power-up, but should not remain lit; a problem is indicated when it does. The green LED on the right is a software-programmable run light that lights when the system is running properly.

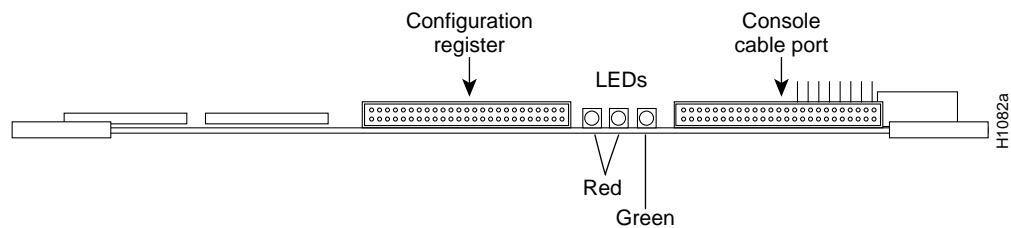

Figure B-2 CSC/3 LED Indicators—Front-Edge View

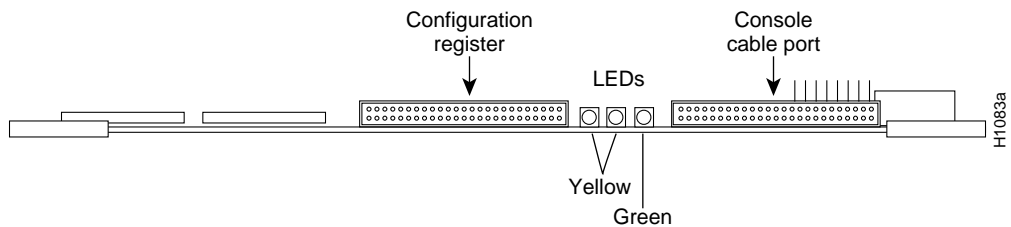

Figure B-3 CSC/4 LED Indicators—Front-Edge View

CSC-C2CTR: LED Indicators

The four interface ports on the CSC-C2CTR card (numbered left to right 0 through 3) each have a corresponding green LED. (See Figure B-4.) These LEDs indicate the status of each port, and each will light when a port is actively connected to its corresponding ring. The LED is off when the port is inactive (or the ring is inactive), administratively down, or not connected to the ring.

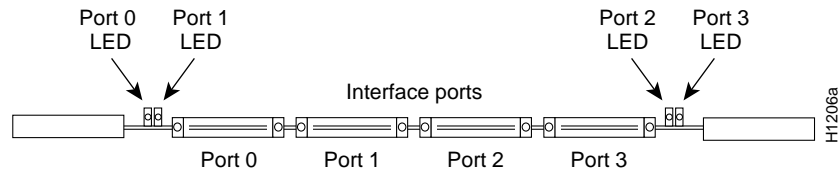

Figure B-4 CSC-C2CTR LED Indicators—Front-Edge View

CSC-CCTL and CSC-CCTL2: LED Indicators

The following sections discuss the LED indicators on the CSC-CCTL and CSC-CCTL2 ciscoBus controller cards.

CSC-CCTL Card

Figure B-5 illustrates the LEDs that light when a card is present in a corresponding ciscoBus slot. (The orientation of Figure B-5 is looking at the front edge of the card installed in the card cage.) The numbers above each LED indicate the ciscoBus slot number. Depending upon the slot in which the ciscoBus card is installed (slot 0 through 3), the corresponding LED will light to indicate a card in that slot. Some ciscoBus cards have appliques that require power from the card to which they attach. If these appliques are not connected correctly, the corresponding LED on the CSC-CCTL will not light. All other LEDs momentarily light at power on, but are not currently used.

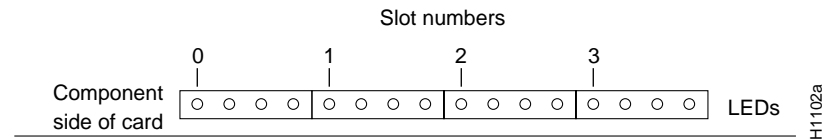

Figure B-5 CSC-CCTL LED Indicators—Partial Front-Edge View

CSC-CCTL2 Card

The LEDs on the CCTL2 card indicate when an interface is present in a ciscoBus slot. The front edge of the CCTL2 card contains a bank of five LEDs as shown in Figure B-6. (The orientation of Figure B-6 is looking at the front edge of the card installed in the card cage.) There is one red LED for each interface slot in the ciscoBus, and a green LED to indicate a successful boot procedure. One red LED will light for each correctly connected ciscoBus card using the correct version of microcode. It will not light if the card is incorrectly connected or if the microcode on that ciscoBus card is the wrong version. Figure B-6 shows the LEDs on the CCTL2 card. The numbers above each LED (0 through 3 from right to left) indicate the ciscoBus slot number assigned to that LED.

Upon power-up, all five LEDs light indicating the CCTL2 card is active. After the system is booted and the ciscoBus controller card microcode has completed its discovery phase, only those red LEDs that indicate the presence of a card in a ciscoBus slot will light. The green LED lights to indicate that the boot operation was successful and that the CCTL2 card firmware version is correct.

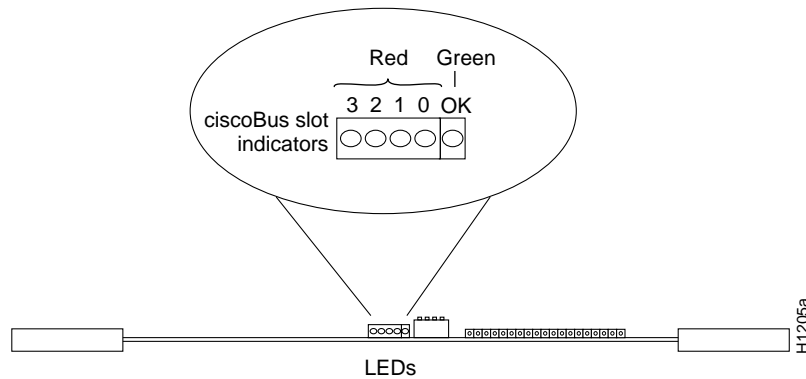

Figure B-6 CSC-CCTL2 Card LED Indicators—Front-Edge View

CSC-ENVM: LED Indicators

The LEDs on the environmental monitor card (CSC-ENVM) are located just to the left of the edge connector on the right front edge of the card. (See Figure B-7.) Table B-2 lists the CSC-ENVM LED functions. LEDs are listed as they appear on the front of the card, from left to right.

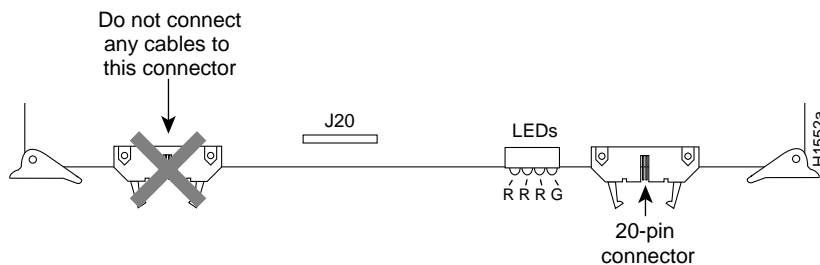

Figure B-7 CSC-ENVM LED Indicators—Partial Component-Side View

Table B-2 CSC-ENVM LED Indicators

LEDs by Color	LED Descriptions
First Red LED (far-left LED)	Normally OFF—This Conditional/Reset LED lights to indicate that the Reset Line has been activated; however, this does not indicate the reset reason, just that the reset condition has been activated.
Second Red LED	Normally OFF—This New Data LED lights to indicate that the system processor is trying to communicate with the CSC-ENVM card.
Third Red LED	Normally OFF—This Interrupt Status LED lights to indicate that an interrupt request has been issued to the system processor and that there may be a problem somewhere within the system.
Green LED (far-right LED)	Normally ON—This Power Available LED lights to indicate that the card is operational and that power (+5V) to the card is applied.

CSC-MCI and CSC-SCI: LED Indicators

The CSC-MCI and CSC-SCI cards contain a bank of 16 LEDs. (Four are currently used.) Table B-3 lists the LEDs that are used and the serial and Ethernet port each LED represents. LED 0 is at the left end of each block of four LEDs (as you view the front edge of the card in the system card cage—shown in Figure B-8 and Figure B-9). At startup, all LEDs flash and then only those LEDs that indicate active interfaces will stay lit. A problem is indicated if all LEDs remain lit after the system boots, or if the LED of a specific interface does *not* stay lit after the system boots.

Table B-3 CSC-MCI and CSC-SCI LED Indicators

LED	MCI Port	SCI Port
0	Ethernet 0	Serial 0
4	Serial 0	Serial 1
8	Ethernet 1	Serial 2
12	Serial 1	Serial 3

When the indicated LED is lit, Carrier Detect (CD) is present on that serial interface, and the interface is enabled. In Ethernet systems, this means that the interface is attached to the Multibus correctly, but is not an indication of complete functionality.

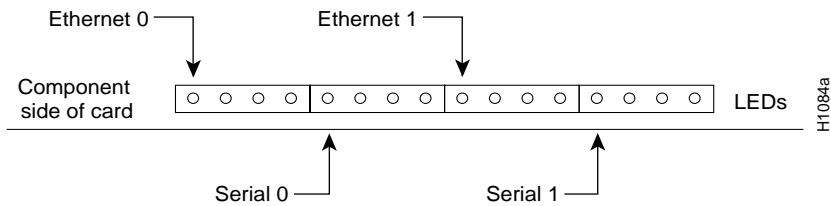

Figure B-8 CSC-MCI LED Indicators—Partial Front-Edge View

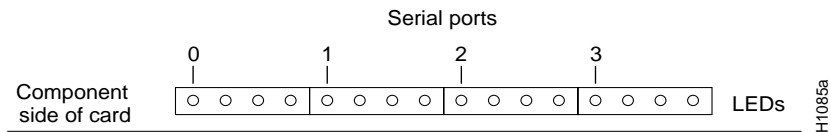

Figure B-9 CSC-SCI LED Indicators—Partial Front-Edge View

CSC-MC+ Flash Memory Card: LED Indicators

The CSC-MC+ has two LEDs on the front edge of the card. (See Figure B-10 and note the *chassis front* orientation of the illustration.) When viewed with the card installed in the card cage, the green LED is on the left. The green LED is the power indicator and should be lit when power is on. The yellow LED is lit during Flash copy operations, and it will be off at all other times. When the write-protect jumper is removed, Flash memory cannot be overwritten or erased.

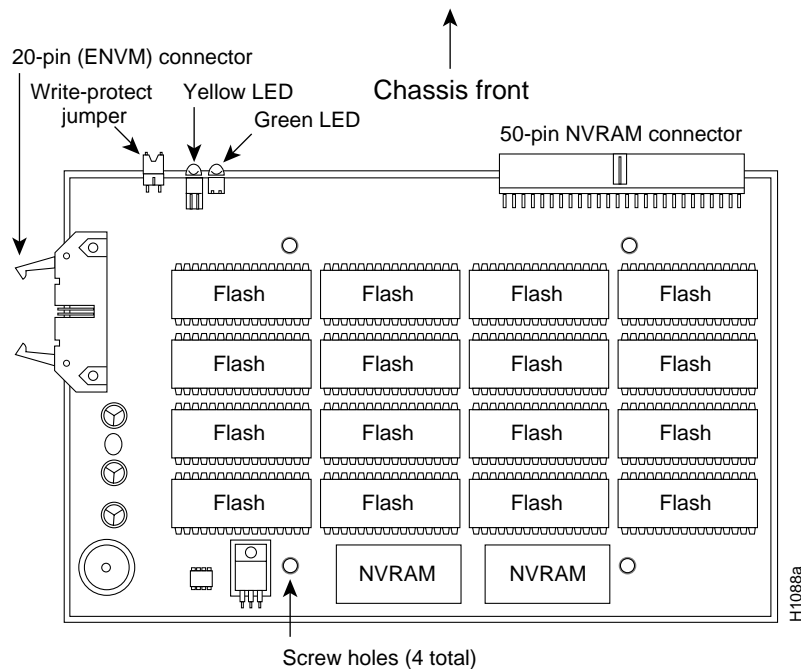

Figure B-10 CSC-MC+ LED Indicators—Component-Side View

CSC-MEC and CSC-C2MEC: LED Indicators

The CSC-MEC cards contain two, four, or six LEDs: one to the right of each Ethernet port on the cards (as you view the front edge of the cards in the system card cage). Figure B-11 shows the CSC-MEC6 card LEDs and the corresponding Ethernet port address (E0 through E5) that each LED represents. The CSC-MEC2 and CSC-MEC4 have two or four LEDs, respectively, with functions identical to those on the CSC-MEC6. With Ethernet systems, a lit LED indicates that the interface port is attached to the Multibus correctly, but it does not necessarily mean that the port is functional. The CSC-C2MEC LED functions are identical to the CSC-MEC.

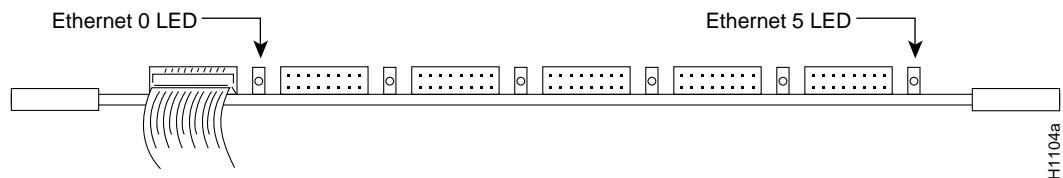

Figure B-11 CSC-MEC6 LED Indicators—Front-Edge View

CSC-R16M Token Ring Card: LED Indicators

The CSC-R16M Token Ring card has 14 LED indicators located on the front edge of the card. (See Figure B-12.) During normal operation, after the card has initialized and the port is connected to the ring, LEDs F through M will strobe back and forth to indicate proper operation. The descriptions of the CSC-R16M LED functions are listed in Table B-4.

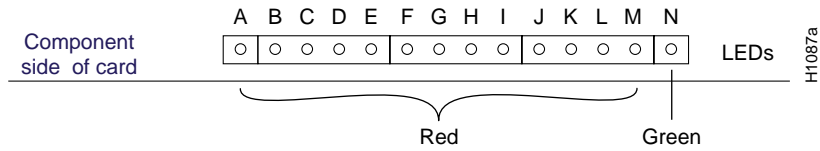

Figure B-12 CSC-R16M LED Indicators—Partial Front-Edge View

Table B-4 CSC-R16M LED Indicators

LED	Function
A	Processor halted (normally off)
B	-12V fused
C	+12V fused
D	+5V fused
E	+5V (power)
F-M	Activity lights ¹
N	Run light (green)

1. LEDs F through M will strobe back and forth to indicate proper operation.

Applique LED Indicators

Checking applique LEDs requires access to the chassis rear panel, which may require removing the system from a rack or closet. In the following serial applique LED tables, the symbols <— and —> indicate signal direction with respect to DCE and DTE devices. For example, “DCE <— DTE” means *signal direction is from DTE to DCE*.

The following LED indicators are included in this section:

- Ethernet 10BaseT
- FDDI (LEDs for the APP-LMM, APP-LMS, APP-LSM, and APP-LSS appliques)
- HSSI high-speed applique (APP-LHS), used with the CSC-(C2)HSCI card
- HD V.35 dual mode (DCE or DTE)
- Other synchronous serial
 - RS-232 DCE and DTE
 - RS-232 SDLC dual mode (DCE or DTE)
 - RS-449 DCE and DTE
- X.21 dual mode (DCE or DTE)

Ethernet 10BaseT Applique: LED Indicators

The Ethernet 10BaseT applique has the following green LED indicators. (See Figure B-13.)

- LINK—Lights when a good link on the Receive Data (RD) pair has been established.
- RCV—Lights to indicate that a packet has been received from the network.
- XMT—Lights to indicate that a packet has been transmitted from the unit.

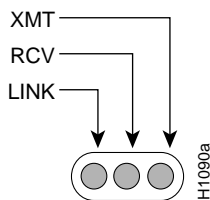

Figure B-13 10BaseT Applique LED Indicators

At power up, the LINK LED lights up and remains lit if it is connected to a 10BaseT link that is powered up. This LED indicates that a good link has been established. If it does not light, check the opposite end of the link to ensure that it is powered up and that the cable is securely installed. If the LED still does not light, switch the transmit and receive pair at one end of the link and restart the system. When a good link is established, the RCV LED will flash or remain lit to indicate packet traffic on the link. The XMT LED will light when the unit transmits data over the link.

If the opposite end of the link is connected to a hub, the hub will perform a *crossover* function, which means that the transmitter from the unit goes to the receiver of the hub, and the transmitter from the hub goes to the receiver of the unit. This configuration is correct; however, if the unit connects to an external media attachment unit (MAU), then the crossover function must be performed in the attaching wires. Otherwise, the two transmit wires are connected to each other, as are the two receive wires.

FDDI Applique: LED Indicators

A bank of nine LEDs, shown in Figure B-14, is located on each FDDI applique to indicate the current line state of each of the two physical connections to the applique (PHY-A and PHY-B, as described in Table B-5). When the ring is operational (when the line protocol is up), the LEDs will oscillate between ILS, ALS, and MLS. (These line states are defined in Table B-5.) The ILS will predominate, so LED 2 will glow most brightly. LED 0 will be slightly dimmer. And LED 1 will be almost dark. The X3T9.5 FDDI specification explains the meaning of these line states in detail.

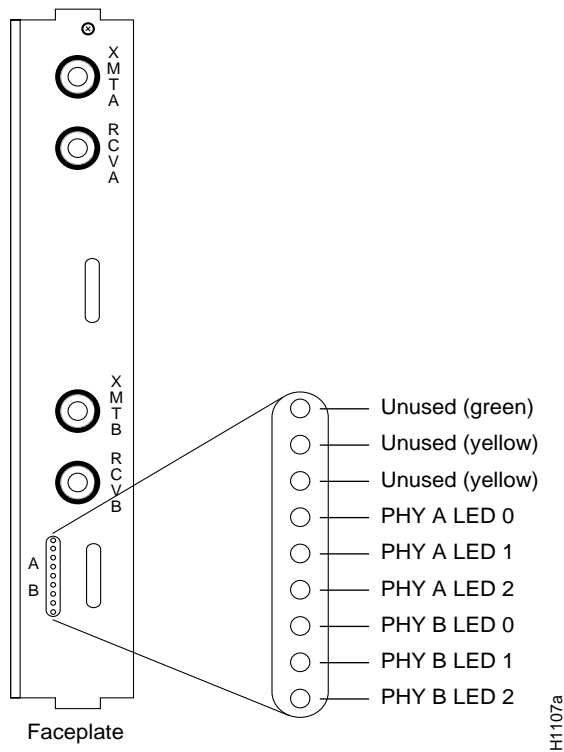

Figure B-14 FDDI Applique LEDs (APP-LSS Shown—Applies to All Four FDDI Applique Models)

Table B-5 Line State Indications for PHY-A and PHY-B LEDs

PHY-x LEDs ¹			
0	1	2	State
O	O	O	Line State Unknown (LSU)
O	O	•	Halt Line State (HLS)
O	•	O	Master Line State (MLS)
O	•	•	Active Line State (ALS)
•	O	O	Noise Line State (NLS)
•	O	•	Quiet Line State (QLS)
•	•	O	Idle Line State (ILS)
•	•	•	Elasticity Buffer Overflow/Underflow (OVUF)

1. O = LED on. • = LED off.

High-Speed Serial Applique: LED Indicators

The high-speed serial applique (APP-LHS) is used with the High-Speed Communications Interface (HSCI) card. The APP-LHS LED indicators are shown in Figure B-15, and their functions and states are listed in Table B-6.

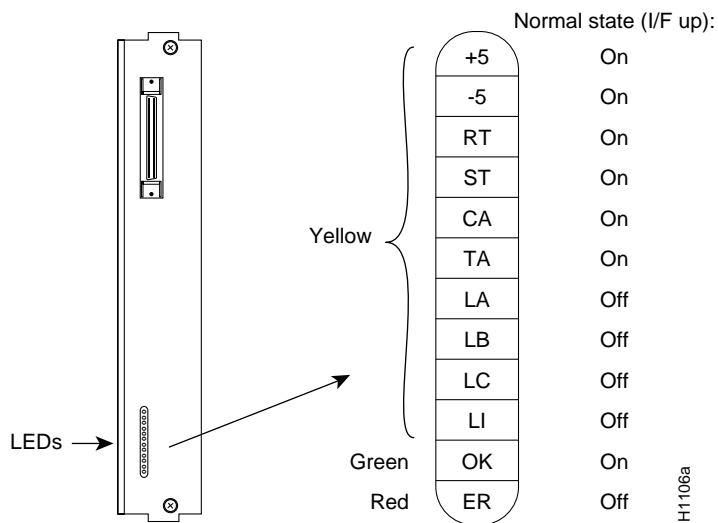

Figure B-15 HSSI Applique (APP-LHS) LED Indicators

Table B-6 APP-LHS LED Indicators

Signals	At Power On ¹	Normal ²	Signal Function	Direction	
				DCE	DTE
+5V	O	O	VCC	—	—
-5V	O	O	VEE	—	—
RT	O	O	Receive Timing	—>	—
ST	O	O	Send Timing	<—	—
CA	O	O	DCE Available	<—	—
TA	O	O	DTE Available	—>	—
LA	•	•	Loopback Circuit A	—>	—
LB	•	•	Loopback Circuit B	—>	—
LC	•	•	Loopback Circuit C	<—	—
LI	O	•	Loopback Internal ³	—	—
OK	•	O	SW OK ⁴	—	—
ER	•	•	Ribbon cable Error	—	—

1. O = LED on, • = LED off.
2. *Normal* means when the interface is UP.
3. For diagnostics only.
4. Set by software.

The Receive Timing (RT) and Send Timing (ST) LEDs indicate that a clock signal is present inside the APP-LHS transmitter and receiver. The clock source is external during normal operation and internal during loopback.

DCE Available (CA) indicates that the DCE data service unit (DSU) is prepared to send and receive data to and from the DTE. DTE Available (TA) indicates the DTE is prepared to send and receive data to and from the DCE (DSU). Data transmission can begin only after both CA and TA have been asserted.

Loopback circuit A (LA), Loopback Circuit B (LB), and Loopback Circuit C (LC) are software-controlled functions. When lit, LA, LB, LC, and Loopback Internal (LI) indicate that the system is in an internal or external loopback diagnostic mode. These loopbacks enable the system diagnostics to verify the links between the DTE and DCE. LA and LB are sent from the DTE to request loopbacks in the DSU. LC is sent by the DCE (DSU) to request loopbacks from the DTE; by default, LC is inhibited by software.

If the DSU supports LC, you must enable it with the **hssi external-loop-request** configuration command before it can be used. If LC is not used, it should remain disabled to avoid noise on the LC line. To disable LC, use the **no hssi external-loop-request** configuration command. Refer to the appropriate optional software publication for more information on using these configuration commands.

The green OK indicator lights after the software has performed its startup verification. The red ribbon cable error (ER) indicator lights when the internal ribbon cable, which is located between the HSCI system card and the APP-LHS applique, is installed incorrectly.

HD V.35 NRZI Dual-Mode Applique: LED Indicators

Table B-7 lists the 15 LEDs that indicate the status of the HD V.35 NRZI synchronous serial applique. LEDs are listed as viewed from left to right on the front of the applique. The LEDs on the applique are located beneath the connector as shown in Figure B-16.

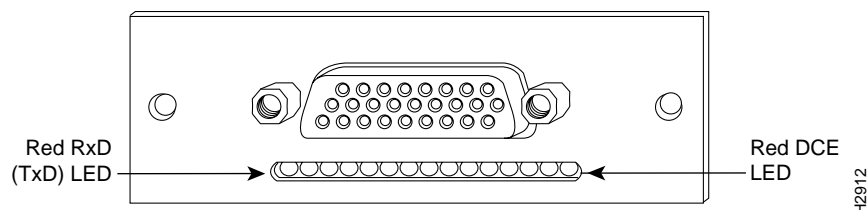

Figure B-16 V.35 NRZI Applique LED Indicators

Table B-7 V.35 NRZI Applique LED Indicators

LED Number	Color	Mnemonic DTE (DCE)	Function	Direction	
				DTE	DCE
1	Red	RxD (TxD)	Receive Data (Transmit Data)	←	→
2	Red	SCR (SCTE)	Serial Clock Receive (Serial Clock Transmit External)	←	→
3	Red	TxD (RxD)	–	→	←
4	Red	SCTE (SCR)	–	→	←
5	Red	DTR	Data Terminal Ready	—	→
6	Red	RTS	Clear To Send	—	→
7	Red	RTS	Request To Send	—	←
8	Red	DCD	Data Carrier Detect	—	←
9	Red	LT	Software Loopback	On if configured “looped”	
10	Green	+5V	+5V present	On if OK	
11	Green	+12V	+12V present	On if OK	
12	Green	–12V	–12V present	On if OK	
13	Green	OK	Applique test OK	On if OK	
14	Green	NRZI/NRZ	NRZI selection	On for NRZI	
15	Red	DCE	Mode selection	On for DCE	

Note Depending on the chassis space available and the position of the applique, the LED pattern orientation may begin from the left or right. In every case, use the green LEDs and the single red LED (toward the end of the row) for the correct pattern orientation.

HD V.35 Dual-Mode Applique: LED Indicators

Table B-8 lists the 14 LEDs that indicate the status of the HD V.35 synchronous serial applique. LEDs are listed as viewed from left to right on the front of the applique. (See Figure B-17). Use the green LEDs toward the end of the row for orientation. The LEDs on the HD V.35 applique are located beneath the connector.

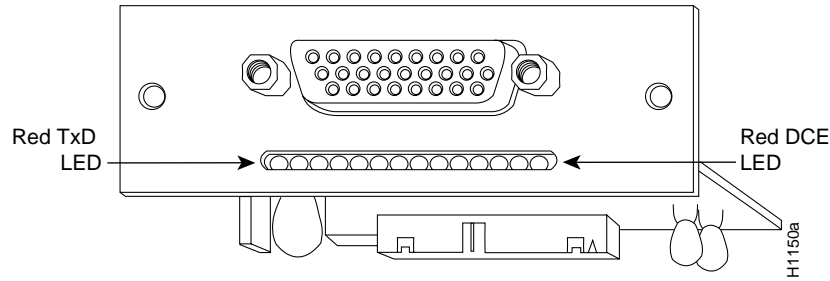

Figure B-17 HD V.35 Applique LED Indicators

Table B-8 HD V.35 Applique LED Indicators

LED Number	Color	Mnemonic DTE (DCE)	Function	Direction	
				DCE	DTE
1	Red	TxD (RxD)	Transmit Data (Receive Clock)	<—	(—>)
2	Red	SCTE (SCR)	Serial Clock Transmit External (Serial Clock Receive)	<—	(—>)
3	Red	RxD (TxD)	—	—>	(<—)
4	Red	SCR (SCTE)	—	—>	(<—)
5	Red	DTR	Data Terminal Ready	—>	
6	Red	CTS	Clear To Send	—>	
7	Red	RTS	Request To Send	<—	
8	Red	DCD	Data Carrier Detect	<—	
9	Red	LT	Software Loopback	<—	
10	Green	+5V	+5V present	On if OK	
11	Green	+12V	+12V present	On if OK	
12	Green	-12V	-12V present	On if OK	
13	Green	OK	Applique test OK	On if OK	
14	Red	DCE	Mode selection	On for DCE	

Other Synchronous Serial Appliques: LED Indicators

On the RS-232, RS-232 Synchronous Data Link Control (SDLC), and RS-449 appliques, the LEDs are located beneath the connectors. These synchronous serial appliques have the lamp pattern shown in Table B-9, except the RS-232 SDLC applique which has two additional LEDs. Use the green LEDs toward the end of the row for orientation. LEDs in Table B-9 are listed as viewed left to right on the applique.

Table B-9 RS-232 DCE and DTE, RS-232 SDLC Dual-Mode, and RS-449 DCE and DTE Applique LED Indicators

Number	Color	RS-232 SDLC	RS-232 DTE	RS-232 DCE	RS-449 DTE	RS-449 DCE
		DTE (DCE)				
1	Red	TxD (RxD)	RxD	RxD	RxD	RxD
2	Red	RxC	RxC	RxC	RxC	SCT/SCR
3	Red	RxD	TxD	RxD	TxD	RxD
4	Red	TxC	TxC	TxC	TxC	RxC
5	Red	DCD	DTR	DCD	DTR	DCD
6	Red	CTS	RTS	CTS	RTS	CTS
7	Red	RTS (CTS)	CTS	CTS	CTS	CTS
8	Red	DTR (DCD)	DCD	DCD	DCD	RLSD
9	Red	LT	LT	LT	LTST	LT
10	Green	+5V OK	+5V OK	+5V OK	+5V OK	+5V OK
11	Green	+12V OK	+12V OK	+12V OK	+12V OK	+12V OK
12	Green	-12V OK	-12V OK	-12V OK	-12V OK	-12V OK
13	Green	Applique OK	Applique OK	Applique OK	Applique OK	Applique OK
14	Red	NRZI/NRZ (on for NRZI)	–	–	–	–
15 ¹	Red	DCE/DTE (on for DTE)	–	–	–	–

1. LEDs 14 and 15 refer to the RS-232 SDLC dual-mode applique only. Numbers are not listed on the applique, but are used here for convenience.

Note The information in Table B-10 refers to the signals shown in Table B-9.

Table B-10 Signal Mnemonics and Directions

Mnemonic	Function	Direction
CTS	Clear To Send	DCE to DTE
DCD	Data Carrier Detect	DCE to DTE
DTR	Data Terminal Ready	DTE to DCE
LT (LTST)	Loopback Test	DTE to DCE
RTS	Request To Send	DTE to DCE
RxC	Receive Clock	DCE to DTE
RxD	Receive Data	DCE to DTE

Mnemonic	Function	Direction
SCT/SCR	Source Clock Transmit/Source Clock Receive	DCE to DTE
TxC	Transmit Clock	DCE to DTE
TxD	Transmit Data	DTE to DCE

X.21 Dual-Mode Applique: LED Indicators

On the X.21 serial applique, the 14 LEDs, which are positioned as shown in Figure B-18, indicate the status of the interface. Use the green LEDs toward the end of the row for orientation. The LEDs are located beneath the connector. The LEDs are listed in Table B-11 as viewed from left to right when facing the front of the applique.

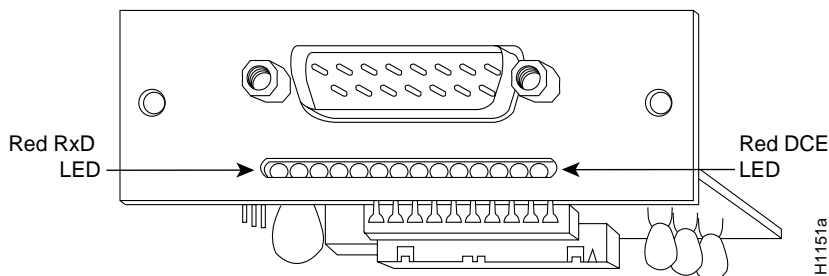

Figure B-18 X.21 Applique LED Indicators

Table B-11 X.21 Applique LED Indicators

LED Number	Color	Mnemonic DTE	Mnemonic DCE	Function	Direction	
					DCE	DTE
1	Red	RxD	TxD	Receive Data	—>	
2	Red	RxC	—	Receive Clock	—>	
3	Red	TxD	RxD	Transmit Data	<—	
4	Red	DCE CLK	DCE CLK	Internal Clock	—>	
5	Red	BDSR	BDSR	Data Set Ready B	—>	
6	Red	RTS/CONTROL	CTS/INDICATE	Request To Send	<—	
7	Red	CTS/INDICATE	RTS/CONTROL	Clear To Send	—>	
8	Red	BDCD/BCTS	BDCD/BCTS	Data Carrier Detect /Clear To Send	—>	
9	Red	—	LOOP ¹	Loopback	<—	
10	Green	+5V	+5V	+5V present	On if OK	
11	Green	+12V	+12V	+12V present	On if OK	
12	Green	-12V	-12V	-12V present	On if OK	
13	Green	OK	OK	Applique test OK	On if OK	
14	Red	DCE	DCE	DCE Mode	On for DCE	

1. Loopback is available in DCE mode only.

